

# **UNIFIED FACILITIES CRITERIA (UFC)**

## **HEATING, VENTILATING, AIR CONDITIONING, AND DEHUMIDIFYING SYSTEMS**



**APPROVED FOR PUBLIC RELEASE; DISTRIBUTION UNLIMITED**

UNIFIED FACILITIES CRITERIA (UFC)

**HEATING, VENTILATING, AIR CONDITIONING, AND DEHUMIDIFYING  
SYSTEMS**

Any copyrighted material included in this UFC is identified at its point of use.  
Use of the copyrighted material apart from this UFC must have the permission of the  
copyright holder.

U.S. ARMY CORPS OF ENGINEERS

NAVAL FACILITIES ENGINEERING COMMAND (Preparing Activity)

AIR FORCE CIVIL ENGINEERING SUPPORT AGENCY

Record of Changes (changes indicated by \1\ ... /1/ )

<u>Change No.</u>	<u>Date</u>	<u>Location</u>

## FOREWORD

The Unified Facilities Criteria (UFC) system is prescribed by MIL-STD 3007 and provides planning, design, construction, sustainment, restoration, and modernization criteria, and applies to the Military Departments, the Defense Agencies, and the DoD Field Activities in accordance with [USD\(AT&L\) Memorandum](#) dated 29 May 2002. UFC will be used for all DoD projects and work for other customers where appropriate. All construction outside of the United States is also governed by Status of forces Agreements (SOFA), Host Nation Funded Construction Agreements (HNFA), and in some instances, Bilateral Infrastructure Agreements (BIA.) Therefore, the acquisition team must ensure compliance with the more stringent of the UFC, the SOFA, the HNFA, and the BIA, as applicable.

UFC are living documents and will be periodically reviewed, updated, and made available to users as part of the Services' responsibility for providing technical criteria for military construction. Headquarters, U.S. Army Corps of Engineers (HQUSACE), Naval Facilities Engineering Command (NAVFAC), and Air Force Civil Engineer Support Agency (AFCESA) are responsible for administration of the UFC system. Defense agencies should contact the preparing service for document interpretation and improvements. Technical content of UFC is the responsibility of the cognizant DoD working group. Recommended changes with supporting rationale should be sent to the respective service proponent office by the following electronic form: [Criteria Change Request \(CCR\)](#). The form is also accessible from the Internet sites listed below.

UFC are effective upon issuance and are distributed only in electronic media from the following source:

- Whole Building Design Guide web site <http://dod.wbdg.org/>.

Hard copies of UFC printed from electronic media should be checked against the current electronic version prior to use to ensure that they are current.

### AUTHORIZED BY:



DONALD L. BASHAM, P.E.  
Chief, Engineering and Construction  
U.S. Army Corps of Engineers



DR. JAMES W. WRIGHT, P.E.  
Chief Engineer  
Naval Facilities Engineering Command

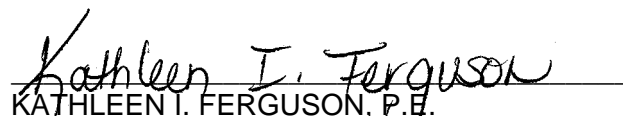

KATHLEEN I. FERGUSON, P.E.  
The Deputy Civil Engineer  
DCS/Installations & Logistics  
Department of the Air Force

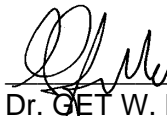

Dr. GET W. MOY, P.E.  
Director, Installations Requirements and  
Management  
Office of the Deputy Under Secretary of Defense  
(Installations and Environment)

CONTENTS

	Page
CHAPTER 1 INTRODUCTION	
Paragraph 1-1 PURPOSE AND SCOPE .....	1-1
1-2 APPLICABILITY .....	1-1
1-2.1 General Building Requirements .....	1-1
1-2.2 Safety .....	1-1
1-2.3 Fire Protection .....	1-1
1-2.4 Antiterrorism/Force Protection .....	1-1
1-2.5 Humid Area HVAC Design.....	1-1
1-3 REFERENCES .....	1-1
APPENDIX A MIL-HDBK 1003/3, NOV 1995.....	A-1

## CHAPTER 1

### INTRODUCTION

1-1 **PURPOSE AND SCOPE.** This UFC is comprised of two sections. Chapter 1 introduces this UFC. Appendix A contains the full text copy of the previously released Military Handbook (MIL-HDBK) 1003/3. This UFC serves as criteria until such time as the full text UFC is developed from the MIL-HDBK and other sources.

This UFC provides general criteria for the design of passive solar buildings.

1-2 **APPLICABILITY.** This UFC applies to all Navy service elements and Navy contractors.

1-2.1 **General Building Requirements.** All DoD facilities must comply with UFC 1-200-01, *Design: General Building Requirements*. If any conflict occurs between this UFC and UFC 1-200-01, the requirements of UFC 1-200-01 take precedence.

1-2.2 **Safety.** All DoD facilities must comply with DODINST 6055.1 and applicable Occupational Safety and Health Administration (OSHA) safety and health standards.

**NOTE:** All **NAVY** projects, must comply with OPNAVINST 5100.23 (series), *Navy Occupational Safety and Health Program Manual*. The most recent publication in this series can be accessed at the NAVFAC Safety web site: [www.navfac.navy.mil/safety/pub.htm](http://www.navfac.navy.mil/safety/pub.htm). If any conflict occurs between this UFC and OPNAVINST 5100.23, the requirements of OPNAVINST 5100.23 take precedence.

1-2.3 **Fire Protection.** All DoD facilities must comply with UFC 3-600-01, *Design: Fire Protection Engineering for Facilities*. If any conflict occurs between this UFC and UFC 3-600-01, the requirements of UFC 3-600-01 take precedence.

1-2.4 **Antiterrorism/Force Protection.** All DoD facilities must comply with UFC 4-010-01, *Design: DoD Minimum Antiterrorism Standards for Buildings*. If any conflict occurs between this UFC and UFC 4-010-01, the requirements of UFC 4-010-01 take precedence.

1-2.5 **Humid Area HVAC Design.** Navy facilities must comply with the requirements in ITG FY05-2, *NAVFAC Humid Area HVAC Design Criteria*.

1-3 **REFERENCES.**

- UFC 1-200-01, *Design: General Building Requirements*, available at the DOD web page: <http://dod.wbdg.org/>.
- UFC 3-600-01, *Design: Fire Protection Engineering for Facilities* available at the DOD web page: <http://dod.wbdg.org/>.

- UFC 4-010-01, *Design: DoD Minimum Antiterrorism Standards for Buildings* available at the DOD web page: <http://dod.wbdg.org/>.
- Interim Technical Guidance (ITG) FY05-2, *NAVFAC Humid Area HVAC Design Criteria* available at the DOD web page: <http://dod.wbdg.org/>.
- DODINST 6055.1 available from the DoD Directives website at <http://www.dtic.mil/whs/directives>.
- OPNAVINST 5100.23 *Navy Occupational Safety and Health Manual* available from the Navy Electronic Directives System at <http://neds.daps.dla.mil/>.

**APPENDIX A**

**MIL-HDBK 1003/3**  
**HEATING, VENTILATING, AIR CONDITIONING AND DEHUMIDIFYING SYSTEMS**

+))))))))) ,  
\* INCH-POUND \*  
.))))))))) -  
MIL-HDBK-1003/3  
15 NOVEMBER 1995

MILITARY HANDBOOK  
HEATING, VENTILATING, AIR CONDITIONING,  
AND DEHUMIDIFYING SYSTEMS



AMSC N/A

AREA FACR

DISTRIBUTION STATEMENT A. APPROVED FOR PUBLIC RELEASE:  
DISTRIBUTION IS UNLIMITED.



ABSTRACT

This handbook is for the use of design and construction of Naval Facilities heating, ventilating, air conditioning, and dehumidifying systems.

## FOREWORD

This handbook is one of a series developed for instruction on the preparation of Navy facilities engineering and design criteria documents. This handbook uses, to the maximum extent feasible, national and institute standards in accordance with Naval Facilities Engineering Command (NAVFACENGCOM) policy. Do not deviate from this handbook for NAVFACENGCOM criteria without prior approval of NAVFACENGCOM Criteria Office, Code 15.

Recommendations for improvement are encouraged from within the Navy, other Government agencies, and the private sector and should be furnished on the DD Form 1426 provided inside the back cover to Commander, Naval Facilities Engineering Command, Mr. Tom Harris, Code 15, 1510 Gilbert Street, Norfolk, VA 23511-2699; phone commercial (804) 322-4206, facsimile machine (804) 322-4416.

THIS HANDBOOK SHALL NOT BE USED AS A REFERENCE DOCUMENT FOR PROCUREMENT OF FACILITIES CONSTRUCTION. IT IS TO BE USED IN THE PURCHASE OF FACILITIES ENGINEERING STUDIES AND DESIGN (FINAL PLANS, SPECIFICATIONS, AND COST ESTIMATES). DO NOT REFERENCE IT IN MILITARY OR FEDERAL SPECIFICATIONS OR OTHER PROCUREMENT DOCUMENTS.

## MECHANICAL ENGINEERING CRITERIA MANUALS

<u>Criteria Manual</u>	<u>Title</u>	<u>PA</u>
MIL-HDBK-1003/1	Plumbing (Proposed)	WESTDIV
MIL-HDBK-1003/2	Incinerators	WESTDIV
DM-3.04	Refrigeration Systems for Cold Storage	WESTDIV
MIL-HDBK-1003/5	Compressed Air and Vacuum Systems (Proposed)	WESTDIV
MIL-HDBK-1003/6	Central Heating Plants	NFESC
MIL-HDBK-1003/7	Fossil Fuel Power Plants (Proposed)	NFESC
MIL-HDBK-1003/8A	Exterior Distribution of Utility Steam, High Temperature Water (HTW), Chilled Water (CHW), Fuel Gas and Compressed Air	NORTHDIV
DM-3.09	Elevators, Escalators, Dumbwaiters, Access Lifts, and Pneumatic Tube Systems	WESTDIV
DM-3.10	Noise and Vibration Control for Mechanical Equipment	ARMY
MIL-HDBK-1003/11	Diesel Electric Generating Plants	NAVFAC
MIL-HDBK-1003/12	Boiler Controls	NAVFAC
MIL-HDBK-1003/13	Solar Heating of Buildings and Domestic Hot Water	NFESC
DM-3.14	Power Plant Acoustics	ARMY
DM-3.15	Air Pollution Control Systems for Boilers and Incinerators	NFESC
MIL-HDBK-1003/17B	Industrial Ventilating Systems	NAVFAC
MIL-HDBK-1003/19	Design Procedures for Passive Solar Buildings	NFESC
MIL-HDBK-1008B	Fire Protection for Facilities Engineering Design and Construction	NAVFAC

## HEATING, VENTILATING, AIR CONDITIONING, AND DEHUMIDIFYING SYSTEMS

## CONTENTS

		<u>Page</u>
<b>Section 1</b>	<b>INTRODUCTION</b>	
1.1	Scope.....	1
1.2	Cancellation.....	1
1.3	Purpose.....	1
1.4	Policy.....	1
1.5	Referenced Criteria.....	2
1.6	Safety.....	2
<b>Section 2</b>	<b>GENERAL</b>	
2.1	Load and Energy Calculations.....	4
2.1.1	Load Calculation Procedures.....	4
2.1.1.1	Load Calculation Form.....	4
2.1.1.2	Design Conditions.....	4
2.1.1.3	Variable Air Volume (VAV) Systems.....	4
2.1.1.4	Outdoor Air Load.....	4
2.1.2	Energy Analysis.....	4
2.1.2.1	Building Orientation.....	4
2.1.2.2	Architectural Features.....	4
2.1.2.3	Mechanical System Selection.....	5
2.1.2.4	Electrical Lighting System Selection (Daylighting)	5
2.1.2.5	Special Energy Conservation Features.....	5
2.2	Equipment Selection.....	6
2.2.1	General.....	6
2.2.2	Heating Equipment.....	6
2.2.2.1	Boiler Sizing.....	6
2.2.2.2	Boiler Fuel.....	7
2.2.2.3	Auxiliary Equipment.....	7
2.2.2.4	Terminal Equipment.....	7
2.2.3	Cooling Equipment.....	7
2.2.3.1	General.....	8
2.2.3.2	Packaged DX Equipment.....	8
2.2.3.3	Central Chilled Water Equipment.....	8
2.2.3.4	Auxiliary Equipment - Cooling.....	8
2.2.4	Ventilation Equipment.....	9
2.2.4.1	General.....	10
2.2.4.2	Humid Climates.....	10
2.2.4.3	Engineered Smoke Control System.....	10
2.2.5	Humidification Equipment.....	10
2.2.5.1	General.....	10
2.2.5.2	Steam Humidifiers.....	10
2.2.5.3	Atomizing Humidifiers.....	10
2.2.6	Temperature Controls.....	10
2.2.6.1	General.....	10

	<u>Page</u>
2.2.6.2	Direct Digital Controls (DDC)..... 11
2.2.6.3	Temperature Control Drawings and Specifications..... 11
2.2.6.4	Automatic Control Valves..... 11
2.2.7	Energy Monitoring and Control System (EMCS) 11
2.2.8	Instrumentation..... 11
2.2.8.1	Indicating Instruments..... 11
2.2.8.2	Recording Instruments..... 11
2.2.8.3	Combination Instrument and Controls..... 13
2.2.8.4	Multi-Point Remote Indicators..... 13
2.2.8.5	Control Board..... 13
2.2.8.6	Desired Instrumentation Characteristics... 13
2.2.9	Metering..... 14
2.2.10	Piping Systems..... 14
2.2.10.1	Sizing..... 14
2.2.10.2	Pipe Expansion..... 14
2.2.11	Duct System Design ..... 14
2.2.11.1	HVAC Systems..... 14
2.2.11.2	Restriction on Use of Ductwork..... 15
2.2.12	Industrial Ventilation and Exhaust Systems. 15
2.3	Noise and Vibration Control..... 16
2.4	System and Equipment Performance..... 16
2.4.1	Cooling Systems..... 16
2.4.1.1	Central Air Conditioning Systems..... 16
2.4.1.2	Unitary Air Conditioning Systems..... 16
2.4.1.3	Room Air Conditioning Units..... 17
2.4.1.4	Built-up Systems..... 17
2.4.2	Heating Systems..... 17
2.4.2.1	Individual Heating Plants..... 17
2.4.2.2	Central Heating Plants..... 18
2.4.2.3	Snow Melting Systems..... 18
2.4.3	All-Air Systems..... 18
2.4.3.1	Constant-Volume Systems..... 18
2.4.3.2	Variable Air Volume (VAV) Systems..... 19
2.4.3.3	Economizer Cycle..... 19
2.4.4	Duct, Pipe, and Equipment Insulation..... 19
2.4.5	Computer Programs for Load Calculation.... 19
2.5	Mechanical Room Ventilation..... 20
2.5.1	Self-Contained Breathing Apparatus (SCBA)... 20
2.6	Radon Mitigation Systems..... 21
<b>Section 3</b>	<b>APPLICATIONS</b>
3.1	General..... 23
3.2	All Building Types..... 23
3.3	Air Force Projects..... 23
3.4	Tropical Engineering..... 23
3.5	Electronic Facilities..... 23
3.6	Air Cargo Terminal..... 29

	<u>Page</u>
3.7	Aircraft Line Operations Building..... 29
3.8	Photographic Building..... 29
3.9	Naval Air Station Control Tower..... 30
3.10	Liquid Oxygen and Nitrogen Facilities..... 30
3.11	Maintenance Facilities for Ammunition, Explosives, and Toxics..... 30
3.12	General Maintenance Facilities..... 30
3.13	Hospital, Dental, and Medical Facilities... 31
3.14	Family Housing..... 31
3.15	Bachelor Enlisted Quarters..... 31
3.16	Bachelor Officer Quarters..... 32
3.17	Industrial Ventilation..... 32
3.18	Kitchen Ventilation..... 32
3.18.1	Kitchen Equipment Exhaust Hoods..... 32
3.18.2	Exhaust Systems..... 32
3.18.3	Fire Protection..... 33
3.18.4	Calculation of Exhaust Hood Air Volume Rate 33
3.18.5	Exhaust Hood Heat Recovery..... 35
3.18.6	Air Curtains..... 36
3.19	Laundries..... 36
<b>Section 4</b>	<b>INFORMATION REQUIRED ON DRAWINGS</b>
4.1	General..... 38
4.1.1	Identification of Drawings..... 38
4.1.2	Equipment Schedules..... 38
4.1.3	Duct Pressure Classifications..... 38
4.1.4	Riser Diagrams..... 38
4.1.5	Controls..... 38
4.1.6	Maintainability..... 39
4.1.7	Symbols and Abbreviations..... 40
4.1.7.1	General..... 40
4.1.7.2	Specifics..... 40
4.1.8	Building Column Lines and Room Names..... 40
<b>Section 5</b>	<b>LOAD CALCULATIONS</b>
5.1	General..... 41
5.2	Heating Load..... 41
5.2.1	Transmission..... 41
5.2.2	Infiltration and Ventilation..... 41
5.2.3	Total Heating Load..... 42
5.3	Cooling Load..... 42
5.3.1	Transmission..... 42
5.3.1.1	Walls and Roof..... 42
5.3.1.2	Glass..... 42
5.3.2	Infiltration and Ventilation..... 43
5.3.3	Internal Loads..... 44
5.3.3.1	People Loads..... 44
5.3.3.2	Lights and Equipment..... 44

		<u>Page</u>
<b>Section 6</b>	<b>AIR DISTRIBUTION</b>	
6.1	Duct Design for HVAC Systems.....	46
6.1.1	Sizing General.....	46
6.1.2	Equal Friction Method Sizing.....	46
6.1.3	Ductwork General.....	46
6.1.3.1	Round Ducts.....	46
6.1.3.2	Rectangular Ducts.....	46
6.1.3.3	Access Doors.....	48
6.1.3.4	Flexible Ducts.....	48
6.1.3.5	Rooftop Ductwork.....	48
6.1.3.6	Glass Fiber Ductwork.....	48
6.1.3.7	Balancing Dampers for HVAC.....	48
6.1.3.8	Fire Dampers and Smoke Dampers.....	50
6.1.3.9	Fan Systems Effect Factors.....	51
6.1.4	Ductwork Details.....	51
6.1.4.1	Branches.....	51
6.1.4.2	Elbows.....	51
6.1.4.3	Offsets and Transmissions.....	51
6.1.5	Testing and Balancing.....	51
6.2	Fans for HVAC Systems.....	51
6.2.1	Fan Selection.....	51
6.2.1.1	Major Types of HVAC Fans.....	51
6.2.1.2	Size.....	51
6.2.1.3	Sound Rating.....	52
6.2.1.4	Static Pressure Requirement.....	52
6.2.1.5	VAV Fan Selection.....	59
6.3	Economizer Cycle.....	59
6.4	Terminal Equipment.....	59
6.5	Louvers.....	60
6.6	Filters for VAV Systems.....	60
6.7	Access for Inspection and Maintenance.....	61
6.8	VAV System Design.....	62
6.9	Ductwork Pressure-Velocity Classification..	62
<b>Section 7</b>	<b>PIPING SYSTEMS</b>	
7.1	General.....	65
7.1.1	Piping Design Factors.....	65
7.1.2	Pipe Friction Loss.....	65
7.1.3	System Pressure Loss.....	65
7.1.4	Piping Layouts.....	65
7.1.5	Expansion.....	65
7.1.6	Expansion Loop.....	66
7.1.7	Packing-Type Expansion and Ball Joints.....	66
7.1.8	Bellows Expansion Joints.....	66
7.1.9	Supports and Anchors.....	66
7.1.10	Flexible Hose.....	68
7.2	Water Systems.....	69
7.2.1	General.....	69

	<u>Page</u>
7.2.1.1	Exterior Water Piping Design..... 69
7.2.1.2	Water Velocity..... 69
7.2.1.3	Water Treatment..... 69
7.2.1.4	Pipe Sizing..... 70
7.2.1.5	Valve and Fitting Pressure Drops..... 70
7.2.1.6	Return Arrangements..... 70
7.2.1.7	Air Vents..... 70
7.2.2	Hot Water Heating Systems..... 70
7.2.2.1	Hot Water Piping..... 70
7.2.2.2	Hot Water Coils..... 70
7.2.2.3	Expansion Tanks and Air Separator..... 73
7.2.2.4	Domestic Hot Water Generator..... 74
7.2.2.5	Heat Exchangers..... 74
7.2.2.6	Pumps..... 79
7.2.3	Chilled Water..... 80
7.2.3.1	Pipe Size..... 80
7.2.3.2	Coils..... 80
7.2.3.3	Expansion Tanks..... 80
7.2.3.4	Pumps..... 80
7.3	Steam..... 81
7.3.1	General..... 81
7.3.2	Low Pressure Steam Systems..... 81
7.3.2.1	Pipe Sizing..... 81
7.3.3	High Pressure Steam Systems..... 81
7.3.3.1	Pipe Sizing..... 81
7.3.3.2	Boiler..... 89
7.3.3.3	Heat Exchanger..... 89
7.3.3.4	Steam Pressure Regulating Valves..... 89
7.3.3.5	Condensate Pumps and Flash Tank..... 92
7.3.3.6	Steam Coils - General..... 92
7.3.3.7	Steam Traps..... 92
7.3.4	Boilers..... 92
7.3.5	Freezing of Steam Coils - General..... 97
7.3.5.1	Freezing Due to Air Stratification..... 97
7.3.5.2	Freezing Due to Build-up of Condensate in the Coil..... 98
7.3.6	Refrigerant Piping..... 101
7.3.6.1	General..... 101
7.3.6.2	Sizing..... 101
7.3.6.3	Arrangement..... 101
<b>Section 8</b>	<b>CONTROLS AND INSTRUMENTATION</b>
8.1	General Requirements..... 104
8.1.1	Choice of Controls..... 104
8.1.1.1	A Guide to Choose Control Systems..... 104
8.1.1.2	Factors to Select Control Systems..... 104
8.1.2	Designing DDC Systems..... 105



	<u>Page</u>
8.2	Standard Sequences of Operations.....107
8.2.1	General Requirements.....107
8.2.2	Operation of HVAC System.....107
8.2.3	Operation of Outside Air, Return Air, and Exhaust (Relief) Air Dampers.....107
8.2.4	Operation of Filtration System.....107
8.2.5	Operation of Freeze Protection.....108
8.2.6	Operation of Smoke Detectors.....108
8.2.7	Operation of Chilled Water Coil Discharge Control.....108
8.2.8	Operation of Preheat Coil Control.....108
8.2.9	Operation of Heating Coil Control.....108
8.2.10	Operation of Space Control (Single Zone Unit).....108
8.2.11	Operation of Space Control (Multizone Unit).....109
8.2.12	Operation of Space Control (VAV Terminal Unit - Pressure Dependent).....109
8.2.13	Operation of Supply Duct Pressure Control..109
8.3	Single Zone Unit Sequence of Operation....109
8.4	Multizone Unit Sequence of Operation.....110
8.5	Variable Air Volume (VAV) Unit Sequence of Operation.....119
8.6	Commissioning Procedures.....124
8.6.1	Functional Performance Test.....124
8.6.2	Preparation for Acceptance Testing.....125
8.6.3	System Static Checkout.....125
8.6.3.1	Observation.....125
8.6.3.2	Calibration.....125
8.6.3.3	Operation.....126
8.6.4	System Dynamic Checkout.....126
8.6.4.1	Controller Manual-Tuning Procedure.....126
8.6.5	Procedures for Single Zone Control System..128
8.6.6	Procedures for Multizone Control System...130
8.6.7	Variable Air Volume (VAV) Control System...132
<b>Section 9</b>	<b>EQUIPMENT LOCATION</b>
9.1	General.....135
9.2	Specific Considerations.....135
9.2.1	Noise.....135
9.2.2	Access for Operations and Maintenance.....135
9.2.3	Blocked Access.....136
9.2.4	Emission of Odors.....136
9.2.5	Cooling Tower Vibration.....136
<b>Section 10</b>	<b>FUNDAMENTAL DRAWING DETAILS</b>
10.1	General.....137
10.2	Specifics.....137

		<u>Page</u>
10.2.1	System Diagrams and Schematics.....	137
10.2.2	Equipment Schedules.....	137
10.2.3	Riser Diagrams.....	137
10.2.4	Duct Pressure Classifications.....	137
10.2.5	Symbols and Abbreviations.....	137
<b>Section 11</b>	<b>RULES OF THUMB GUIDANCE</b>	
11.1	General.....	144
11.2	Air Conditioning Capacity.....	144
11.3	Heating Capacity.....	144
11.4	Moisture Loads.....	144
11.5	Chilled Water Circulation.....	144
11.6	Hot Water.....	144
11.7	Condenser Water.....	144
11.8	Steam.....	144
11.9	Condensate.....	144
<b>Section 12</b>	<b>FIRE PROTECTION AND SMOKE CONTROL</b>	
12.1	General.....	146
12.2	System Design.....	146
12.3	Engineered Smoke Control System.....	147

## APPENDICES

APPENDIX A	Energy Conservation Methods.....	148
APPENDIX B	Engineered Smoke Control Systems.....	172
APPENDIX C	Design Do's and Don'ts VAV Systems.....	173
APPENDIX D	Variable Speed Drives (VFD's).....	186

## FIGURES

Figure 1	Floor Penetration for Sub-Slab Depressurization System.....	22
2	Duct Sizing.....	47
3	Damper Installation.....	49
4	Fan System Effect Factors.....	53
5	Duct Branches.....	54
6	Duct Branches.....	55
7	Duct Elbows.....	56
8	Duct Offsets and Transitions.....	57
9	Hooked Louver Blade.....	62
10	Duct Pressure Class Designation.....	64
11	Friction Loss for Water in Commercial Steel Pipe (Schedule 40).....	71
12	Friction Loss for Water in Copper Tubing (Types K, L, M).....	71
13	Friction Loss for Water in Plastic Pipe (Schedule 80).....	72

	<u>Page</u>
14	Closed Expansion Tank..... 75
15	Diaphragm Expansion Tank..... 76
16	Connections to Converter for Hot Water Heating System..... 77
17	Domestic Hot Water Generator and Heating Hot Water Boiler Piping Connection..... 78
18	Chart for Flow Rate and Velocity of Steam in Schedule 40 Pipe Based on Saturation Pressure of 30 psig..... 85
19	Chart for Flow Rate and Velocity of Steam in Schedule 40 Pipe Based on Saturation Pressure of 50 psig..... 86
20	Chart for Flow Rate and Velocity of Steam in Schedule 40 Pipe Based on Saturation Pressure of 100 psig..... 87
21	Chart for Flow Rate and Velocity of Steam in Schedule 40 Pipe Based on Saturation Pressure of 150 psig..... 88
22	PRV--Low Pressure..... 90
23	Two Stage PRV..... 91
24	Flash Tank and Duplex Condensate Pump Unit.. 93
25	Steam Coils..... 94
26	Steam Tempering Coils..... 95
27	Low Pressure Drip..... 96
28	Boiler Connections..... 97
29	Air Stratification to Coil During Freeze-up Conditions..... 99
30	Nonfreeze Coil Piping.....100
31	Refrigerant Coil.....102
32	Compressor Piping.....103
33	Control System Schematic for Single Zone HVAC System XX.....111
34	Control System Schematic for Multizone HVAC System XX.....115
35	Control System Schematic for VAV HVAC System XX.....121
36	Schematic Hot Water and Chilled Water Balancing Diagram.....138
37	Schematic Airflow Balancing Diagram.....139
38	Hot Water Riser Diagram.....141
39	Notes on Drawing Riser Diagram.....142
40	Designating Duct Pressure Classes.....143
A1	Occupied/Unoccupied Hot Water Reset Schedule.....149
A2	Thermostat Setpoints Diagram.....151
A3	Exhaust Air Heat Recovery With Rotary Air Wheel.....154

	<u>Page</u>
A4	Exhaust Air Heat Recovery With Counterflow Pattern Static Heat Exchanger.....155
A5	Exhaust Air Heat Recovery with Crossflow Pattern Static Heat Exchanger.....156
A6	Exhaust Air Heat Recovery Method With Heat Pipe.....157
A7	Exhaust Air Heat Recovery Method With Runaround (Closed Loop) System.....158
A8	Exhaust Air Heat Recovery Method With Runaround (Open Loop) System.....160
A9	Heat of Light Recovery Method With Light Troffer.....162
A10	Heat of Light Recovery Method With Induced Air.....163
A11	Refrigeration Method Heat Recovery With Conventional Refrigeration Machine Using Hot Water Coil.....165
A12	Refrigeration Method Heat Recovery With Conventional Refrigeration Machine Using Refrigerant Coil.....166
A13	Refrigeration Method Heat Recovery With Internal Source Heat Pump.....167
A14	Refrigeration Method Heat Recovery With Single Bundle Condenser Water Circuit Method and Open Cooling Tower.....168
A15	Refrigeration Method Heat Recovery With Double Bundle Condenser Water Circuit Method.....169

## TABLES

Table	1	Recommended Air Conditioning Systems for Various Buildings.....	3
	2	Typical Instrument Applications.....	12
	3	Applicable Criteria by Building Type.....	24
	4	Thermal Currents Charts.....	34
	5	Safety Factor Chart.....	35
	6	Duty Group Chart.....	35
	7	Major Types of HVAC Fans.....	58
	8	Piping Materials.....	67
	9	Water Velocities.....	69
	10	Flow Rate in lb/h of Steam Schedule 40 Pipe.	82
	11	Return Main and Riser Capacities for Low-Pressure System, lb/h.....	83
	12	Comparative Capacity of Steam Lines at Various Pitches for Steam and Condensate Flowing in Opposite Directions.....	83

	<u>Page</u>
13	Steam Pipe Capacities for Low-Pressure Systems..... 84
14	Common Types of Steam Traps..... 96
15	Equipment for Single Zone HVAC Control System XX.....113
16	Equipment for Multizone HVAC Control System XX.....116
17	Equipment for VAV HVAC Control System XX....123
18	Typical Utility Fan Schedule.....140
19	Sound Data Schedule.....140
20	Cooling Coil Schedule.....140
21	Air Conditioning Load Estimating Factors....145
22	Typical Load Breakdown of Dehumidified Warehouse.....145
<a href="#">REFERENCES</a>	.....205
<a href="#">GLOSSARY</a>	.....210

Section 1: INTRODUCTION

1.1 Scope. This handbook provides the Naval Facilities Engineering Command's policy and criteria for selection and design of heating, ventilating, air conditioning (HVAC), and dehumidifying systems as applied to Naval shore facilities.

1.2 Cancellation. This handbook cancels and supersedes NAVFAC design manual DM-3.03, Heating, Ventilation, Air Conditioning and Dehumidifying Systems dated January 1987.

1.3 Purpose. Policy and criteria included in this handbook are provided to ensure quality and consistency in design of HVAC and dehumidifying systems with minimum life cycle costs which satisfy functional and operational requirements of Naval facilities and which provide a healthy and safe environment for facility occupants.

1.4 Policy. Design of HVAC and dehumidifying systems shall be in accordance with guidelines included in this handbook. The material included in Sections 5 through 12 of this handbook is provided for information and should be applied only as required to supplement the experience of the designer or design reviewer. NAVFAC policy is to select simple, easy to maintain and operate, HVAC systems designed based upon well established principles and constructed of proven materials that satisfy space temperature, humidity, and indoor air quality (IAQ) requirements within energy budgets prescribed in MIL-HDBK-1190, Facility Planning and Design Guide. Use the following procedures for selection and design of HVAC systems:

a) Ensure that passive building design features, e.g., building orientation, shading, building envelope, and insulation are optimized to reduce heating and cooling loads. Such passive techniques reduce the requirement to use complex, maintenance intensive, HVAC systems and equipment to meet the facility energy budget.

b) Place special emphasis on keeping HVAC systems, including controls, simple and easy to operate and maintain. Table 1, par. 2.4, and subparagraphs provide recommendations on types of air conditioning systems that should be considered for the most common applications. The least complex of the recommended types should be selected based on functional requirements, ease of maintenance, and the design energy budget. For example, a system requiring extensive use of complex controlled devices and associated controls (e.g., complex heat recovery systems) should only be considered when there are no practical alternatives to obtain design energy budgets prescribed

in MIL-HDBK-1190. Otherwise, less complex, constant volume unitary or air handler systems with zone control should be used.

c) Consider the level and responsiveness of maintenance available at the customer's activity when selecting the HVAC system. Success of the HVAC system is dependent upon acceptance of the system by the local staff responsible for routine maintenance. The staff should be able to understand the operating principles and control logic. Maintenance of the system should not require skills and knowledge beyond their capability. Ensure adequate space is provided for equipment maintenance and removal.

d) Consider the types of systems currently installed at an activity when making system selection for new facilities. Seek to provide consistency in system types unless a simpler, less maintenance intensive system can be used in the new facility.

e) Specify training of activity personnel comparable to the degree of system and controls complexity provided and considering level of existing knowledge. In addition, provide customer guidance relative to maintenance personnel (including level of knowledge) or contract maintenance support required for the HVAC system.

1.5 Referenced Criteria. The principal criteria references used in this handbook in order of priority are:

a) MIL-HDBK-1190.

b) NAVFAC design manuals and military handbooks. (Whenever a design manual is revised, the design manual is converted to a military handbook.)

c) American Society of Heating, Refrigerating and Air-Conditioning Engineers, Inc. (ASHRAE) handbooks and standards. If a particular subject is not specifically addressed in this handbook, ASHRAE criteria apply. For criteria that is not available in ASHRAE criteria, use the best available information applicable to the design requirement, including State and local codes as applicable.

1.6 Safety. Design systems to meet requirements of National Fire Protection Association (NFPA) 90A, Standard for the Installation of Air Conditioning and Ventilating Systems and NFPA 90B, Standard for the Installation of Warm Air Heating and Air Conditioning Systems and Department of Labor, 29 CFR Part 1910, Occupational Safety and Health Standards.

Table 1  
Recommended Air Conditioning Systems  
for Various Buildings

Building	SYSTEMS (1)								
	A	B	C	D	E (2)	F (3)	G	H	I (3)
Administration	X	X	X	X	X	X	X	X	X
Apt. Houses	-	-	X	-	-	X	X	X	-
Auditoriums	X	X	X	X	-	X	-	X	X
Bachelor Quarters	X	X	X	X	X	X	X	X	X
Bakeries	X	X	X	X	-	-	-	X	X
Chapels	X	X	X	X	-	X	X	X	X
Communications	X	X	X	X	-	X	X	X	X
Family Housing	X	-	X	-	-	X	X	X	X
Gymnasiums	X	-	-	-	-	-	-	-	X
Hangar (w/Lean-To)	-	-	-	-	-	X	X	-	X
Hospitals	X	X	X	X	-	X	X	X	X
Laundries	X	X	X	X	-	-	-	X	X
Schools	X	X	X	X	-	X	X	X	X
Shops	X	X	X	X	-	X	-	-	X
Theaters	X	X	X	X	-	X	-	-	X
Transmitters	X	X	X	X	-	X	-	-	X
Warehouses	X	-	X	-	-	-	-	-	X

NOTES:

(1) System Types:

A - Single Duct System	F - Fan Coil System
B - Dual Duct System	G - Induction System
C - Multizone System	H - Heat Pump System
D - Variable Volume System	I - Evap. Cooling System
E - Perimeter Zone Air System	

(2) Depends on building configuration.

(3) Depends on local weather conditions. Refer to MIL-HDBK-1190.



Section 2: GENERAL

2.1 Load and Energy Calculations

2.1.1 Load Calculation Procedures. Refer to the ASHRAE Handbook, Fundamentals, for the acceptable method of performing load and energy calculations.

2.1.1.1 Load Calculation Form. Except for small buildings and minor renovation, less than 8000 square feet, loads should be calculated using a computer program which applies one of the methods in the ASHRAE Handbook, Fundamentals, Chapters 25 and 26. Simplified load calculation equations are reproduced in Section 5 of this handbook. These simplified equations may be used on smaller buildings with hand calculations.

2.1.1.2 Design Conditions. Select indoor and outdoor summer and winter design conditions in accordance with MIL-HDBK-1190. If a known micro-climate condition exists at the site, or if building site location is not shown in NAVFAC Publication P-89, Engineering Weather Data; consult the Navy design manager or project leader (DM or PL) for instructions.

2.1.1.3 Variable Air Volume (VAV) Systems. For VAV systems, refer to Appendix C and ASHRAE Handbook, Fundamentals, for the acceptable method.

2.1.1.4 Outdoor Air Load

a) Infiltration. Use infiltration rates and the method of calculation prescribed in ASHRAE Handbook, Fundamentals.

b) Ventilation. Use ventilation rates for IAQ prescribed in ASHRAE Standard 62, Ventilation for Acceptable Indoor Air Quality and the method of calculation included in ASHRAE Handbook, Fundamentals.

2.1.2 Energy Analysis

2.1.2.1 Building Orientation. Building orientation, fenestration, lighting, and geometry can have a profound effect on the building energy consumption, system selection, and zoning. Therefore, the HVAC designer should consult with the architect during the early concept stage to optimize the overall design.

2.1.2.2 Architectural Features. The building mass, tightness of construction, window treatment, occupancy zoning, and other characteristics can also impact the HVAC design. These features

need early consideration by the design disciplines to achieve the best overall design concept. Consider using ENVSTD 24, a Department of Energy (DOE) envelope system performance compliance calculation program to assist the architect and mechanical engineer to evaluate the proposed facilities' compliance with ASHRAE Standard 90.1, Energy Efficient Design of New Buildings Except Low-Rise Residential Buildings, 10 CFR 435, and MIL-HDBK-1190 design energy targets. ENVSTD 24 is available on the Construction Criteria Base (CCB) CD-ROM, or from ASHRAE or DOE.

2.1.2.3 Mechanical System Selection. Life cycle cost analysis of candidate systems should be used to determine the best system selection within the parameters cited in par. 1.4. Include electrical demand charges as well as energy charges in the analysis. Include rebates offered by the utility for use of particular forms of energy or types of equipment, such as ice storage or gas-fired adsorption chillers. Refer to MIL-HDBK-1190 for guidance on the application of this procedure.

2.1.2.4 Electrical Lighting System Selection (Daylighting). The HVAC design engineer should assist in the evaluation of daylighting to ensure that electrical energy savings are not offset by increased energy required by the HVAC system due to increased heating and cooling loads. Consider using LTGSTD 24, a DOE lighting prescriptive and system performance compliance calculation program to assist the architect and electrical and mechanical engineer to evaluate the proposed facilities compliance with ASHRAE Standard 90.1, 10 CFR Part 435, Energy Conservation Voluntary Performance Standards for Commercial and Multi-Family High Rise Residential Buildings, Mandatory for New Federal Buildings and MIL-HDBK-1190 design energy targets. LTGSTD 24 is available on the CCB CD-ROM or from ASHRAE or DOE.

2.1.2.5 Special Energy Conservation Features. There remains a continuing need to achieve energy conservation on Navy buildings by optimization of new building designs, accurate control systems, retrofit of older buildings, and incorporation of special energy conservation features wherever appropriate (as justified by life cycle cost).

a) Solar. Include active and passive solar systems for space heating, for heating pools, and for domestic hot water only if economically feasible. A new economic analysis need not be performed if a previous study on a similar facility with similar weather conditions is available.

b) Heat Recovery Techniques. Refer to Appendix A for an exposition of some of the various techniques of heat recovery.

Application of these techniques should only be considered when required to meet the design energy budget and when operation and maintenance are judged to be within the capability of local maintenance personnel.

c) Thermal Storage. Due to the added complexity in system operation and controls, only use thermal storage systems when required to meet the building energy budget and when proven cost effective on a life cycle cost basis.

(1) Savings. Include demand charges, energy charges (energy cost may be lower when thermal storage is charged off peak), and savings in refrigeration equipment size reduction in the life cycle cost analysis. An electric rate structure with a high demand charge or with time-of-day metering rates provides the best opportunity for savings on investment. Ensure that the analysis includes the appropriate energy cost, e.g., billing for electrical energy at a master meter vice the individual building meter. If the station is master metered for consumers, addition of a single building may have no significant impact on the demand charge, and additional energy used may be at the lowest available rate. Other opportunities for savings include reduced cost for electric service, increased efficiency of equipment operating at night, and reduced cost for fire protection if water storage can be integrated with thermal storage requirements.

(2) Equipment Selection. Packaged thermal storage systems complete with controls are preferred over field fabricated systems.

## 2.2 Equipment Selection

2.2.1 General. Determine the type of heating and cooling system to be used by the computer energy and life cycle cost analysis as described in MIL-HDBK-1190, Chapter 8. Applicable Navy design manuals and guide specifications provide guidance on the recommended classes of equipment to be evaluated for the particular application and size range.

### 2.2.2 Heating Equipment

2.2.2.1 Boiler Sizing. Refer to MIL-HDBK-1003/6, Central Heating Plants and ASHRAE Handbook, Fundamentals for sizing boilers. Boiler sizing should consider:

a) Connected load, which includes the heating load, plus (where applicable) pipe loss and pickup, domestic hot water, process loads, and boiler plant auxiliaries.

b) Boiler plant's turndown ratio.

c) Provisions for future loads and standby for essential loads where applicable.

2.2.2.2 Boiler Fuel. Refer to MIL-HDBK-1003/6 for information on how to select boiler fuel. Consider Navy criteria, fuel and life-cycle costs, and Federal and local emission standards.

2.2.2.3 Auxiliary Equipment. Refer to MIL-HDBK-1003/6 and Navy guide specifications for information on types and sizing of auxiliary equipment. Some notes on plant equipment are as follows:

a) Centrifugal Pumps. Check the system net positive suction head (NPSH) as well as the pump NPSH in the design. In the past, engineers frequently specified non-overloading type pumps. Today, pumping energy costs sometimes dictate other ways to arrange pump operating points. Do not oversize pumps. Refer to the ASHRAE Handbook, Fundamentals and the Hydraulic Institute standards for guidance on design of centrifugal pumping systems.

b) Non-Hermetic Motors. Refer to ASHRAE Handbook, Fundamentals; NFPA 70, National Electrical Code; and National Electrical Manufacturers Association (NEMA) standards for guidance on selecting motors and motor protective devices.

c) Hermetic Motors. Hermetic motors are used in refrigeration compressors, selected by the equipment manufacturer, and protected as required by NFPA 70.

d) Engine and Turbine Drives. Consult ASHRAE Handbook, Fundamentals and applicable NFPA standards for design guidance on the application of engines and turbines used to drive compressors, fire pumps, power generators, and co-generation equipment.

2.2.2.4 Terminal Equipment. Select and size terminal equipment in accordance with ASHRAE Handbook, Fundamentals. Economic as well as engineering considerations shall set the flow, temperature, temperature drop, pressure, and pressure drop for central plant equipment; distribution piping and fittings; and terminal equipment parameters. If new terminal equipment is added to an existing plant, ensure that the new system piping and valves will not disturb the proper operation of existing distribution system.

2.2.3 Cooling Equipment

2.2.3.1 General. Select air cooled equipment on the basis of entering air at 5 degrees F above the design temperature as given in NAVFAC P-89 for roof mounted equipment and for equipment in corrosive environments.

2.2.3.2 Packaged DX Equipment. Multiple packaged DX equipment should only be used when it is shown to be life cycle cost effective for the application.

2.2.3.3 Central Chilled Water Equipment

a) Use only one chiller for comfort cooling applications unless it becomes economical to split capacity. Mission requirements may dictate the use of multiple units with capacities determined by critical loads. Obtain approval for the use of multiple units from the engineering field division (EFD) or engineering field activity (EFA).

b) Size units on the basis of acceptable refrigerants specified in NAVFAC guide specification (NFGS)-15652, Central Refrigeration Equipment for Air Conditioning. Do not use refrigerants with an ozone depletion potential (ODP) greater than 0.05 or a global warming potential (GWP) greater than 0.34.

c) Use centrifugal or rotary screw compressor chillers for capacities greater than 120 tons.

d) Though air cooled chillers are less efficient than water cooled chillers, air cooled chillers require less maintenance; this should be a consideration in the selection.

e) Water treatment of cooling towers and evaporative condensers should be carefully considered. Continuous bleeding or dumping of water treated with chemicals to the sanitary or storm sewer may be prohibited. Check with the local environmental program manager for use of wastewater and sanitary sewer systems.

2.2.3.4 Auxiliary Equipment - Cooling

a) Condenser Heat Rejection. Heat can be rejected from a condensing refrigerant to atmosphere with an evaporative condenser, with a water-cooled condenser and a cooling tower, with an air-cooled condenser, or with closed ground-loop water rejection. Do not use potable water for condenser heat rejection. Provide a three-way diverter valve to control condenser cooling water supply temperature. Cooling with pond, stream, or lake water should only be considered after evaluating environmental impact of returning heated water and additional

associated maintenance costs. Condenser heat can also be recovered for space heating including reheat and domestic water heating.

b) Evaporative Condenser. An evaporative condenser yields high efficiency because of its low condensing temperature, and is smaller than an air-cooled condenser or cooling tower. Although the evaporative condenser is often mounted on the roof, it may be mounted inside the building and ducted to the outside. It requires less maintenance than a cooling tower because the water treatment is easier. Provide capacity control by cycling the fan, using a two speed fan and modulating dampers. Use a dry sump piped to an inside reservoir in freezing climates.

c) Cooling Tower. A cooling tower also yields high efficiency with its low condensing temperature. It can be designed to give "free" cooling (e.g., cooling when the refrigeration compressor motor is not running) with special piping or using a special refrigeration compressor. Continuous bleed off is required to prevent excessive concentration of solids. Chemical treatment is used to inhibit microorganisms, control corrosion and scale, and to keep silt in suspension. Locate cooling towers to prevent short circuit of moist air; and so that drift from the tower will not water spot parked cars, large windowed areas, or sensitive architectural surfaces. Locate the condenser water pump below or alongside the tower basin to ensure an adequate NPSH. Heat the basin or use a dry sump and remote reservoir in freezing climates. Provide capacity control by cycling the fan.

d) Air Cooled Condenser. Because an air cooled condenser is governed by the outdoor air dry bulb temperature, it has higher condensing temperature and a lower energy efficiency than an evaporative condenser or cooling tower installation. Maintenance costs and labor requirements are much lower with air cooled condensers than with cooling towers or evaporative condensers.

e) Ground-Loop (Geothermal) Heat Rejection. Use where justified by life cycle cost evaluation and ecological considerations and where space permits. Improved methods of welding plastic pipe provide long-lasting systems (25 years) with minimum maintenance requirements.

#### 2.2.4 Ventilation Equipment

2.2.4.1 General. Combine ventilation equipment for the heating system with ventilation equipment for the cooling system wherever feasible. Use positive methods to ensure adequate ventilation air for IAQ at occupied operating modes.

2.2.4.2 Humid Climates. Independent ventilation systems are required in humid climates for humidity control. Refer to MIL-HDBK-1011/1, Tropical Engineering.

2.2.4.3 Engineered Smoke Control System. Use of smoke control systems should be limited to high rise structures such as hospitals. For detailed information on engineered smoke control systems, refer to ASHRAE Publication, Design of Smoke Control Systems for Buildings, and ASHRAE Handbook, HVAC Systems and Applications, and NFPA 92A, Smoke Control Systems. Refer to Appendix B for notes on design of smoke control systems.

## 2.2.5 Humidification Equipment

2.2.5.1 General. Provide humidification systems when outdoor design conditions would result in an interior space relative humidity less than 20 percent. Combine humidification equipment with HVAC systems when central station air handling equipment is used. Ensure that the building can contain the added moisture without damage. Refer to MIL-HDBK-1191, Medical and Dental Treatment Facilities Design and Construction for medical facilities requirements.

2.2.5.2 Steam Humidifiers. Use of direct steam containing amines is prohibited. Provide moisture eliminators if heated pan humidifiers are used with high pressure steam as a heating source. Makeup water for pan humidifiers should be from a soft water source if available to minimize scaling. Automatic blowdown should be provided on heated pan humidifiers to reduce scaling.

2.2.5.3 Atomizing Humidifiers. Do not use atomizing humidifiers as an alternative to direct steam or heated pan type since these have the potential of injecting the legionnaire bacillus as well as other pathogenic microorganisms into the air distribution system.

## 2.2.6 Temperature Controls

2.2.6.1 General. Design control systems as simple as possible, reducing complexity to only that required to meet design conditions and to provide safe operation. Integrate limit and safety controls as part of the system. Section 8 provides additional general information on control systems.

2.2.6.2 Direct Digital Controls (DDC). Use direct digital controls where justified by life cycle cost for new and major replacement HVAC systems. Verify that activity operating and maintenance personnel will use DDC by contacting the EFD or EFA design manager or project leader.

2.2.6.3 Temperature Control Drawings and Specifications. Comply with NFGS-15972, Direct Digital Control Systems or NFGS-15971, Space Temperature Control Systems. Refer to par. 4.1.5 for information required on drawings.

2.2.6.4 Automatic Control Valves. Use three-way mixing and diverting valves only for two-position switching of water flow and three-way diverting valves for modulating control of cooling tower water. Use two-way modulating valves and variable flow pumping for other automatic control of water flow to achieve energy efficient systems. Three-way valves provide inaccurate control and at mid position tend to pass greater than design flow.

2.2.7 Energy Monitoring and Control System (EMCS). EMCS, which is also called Utility Monitoring and Control System (UMCS), is not a unique system but is a special application of a DDC system. New buildings will provide energy management functions by adding these programs to the DDC system. If an existing EMCS is to be expanded, do so only when the EMCS is proven functional and then comply with Army Technical Manual (TM) 5-815-2, Energy Monitoring and Control Systems (EMCS), otherwise design a DDC system with energy monitoring functions. Do not provide terminal cabinets for a proposed EMCS.

2.2.8 Instrumentation. Where instruments are required for adjustments only and are not essential for normal operation, provide an arrangement to temporarily connect instruments without stopping or draining the system. Comply with Table 2.

2.2.8.1 Indicating Instruments. Specify ranges of operation which give an indication of variation in operating conditions. Measuring instruments shall be provided near automatic control devices, such as thermostats, humidistats, and pressure switches, to facilitate adjustments and testing of the control device. Use indicating types only, unless a permanent operational record is desired.

2.2.8.2 Recording Instruments. Provide recording instruments only where a permanent record is required to analyze operating costs or effects on process applications. If a DDC system is used, this function can be accomplished through software programs.



Table 2  
Typical Instrument Applications

INSTRUMENT	GENERAL LOCATION	SPECIFIC LOCATION
Thermometer	Pipeline	*Water chiller inlet and outlet. *Refrigerant condenser water inlet and outlet. *Chilled and hot-water supply and return from branch mains. *Pipes from coils and heat exchangers.
	Ductwork	*Outdoor air duct. *Return air duct. *After preheat coil, cooling coil, and heating coil.
Thermometer well only	Pipeline	*Individual cooling and heating coil returns. *Direct expansion coil refrigerant suction connection. *Refrigerant suction connection to water chiller.
	Equipment	*Bearings of large compressors and motors.
Pressure indicator	Pipeline	*Before and after pressure reducing valves. *Suction and discharge of pumps and compressors.
	Equipment	*Pressure lubrication system of compressors.
Pressure tapping with gage cocks	Equipment	*Water entering and leaving sides of cooling and heating coils, water chillers, and refrigerant condensers.
Draft gages (not required where DDC sensors are connected)	Equipment	*At static pressure regulators. *Before and after large air filter banks with a capacity above 4,000 cubic feet per minute.

Table 2 (Continued)  
Typical Instrument Applications

INSTRUMENT	GENERAL LOCATION	SPECIFIC LOCATION
Tappings for draft gages	Equipment	*Suction and discharge of fans. *Induction unit risers. *Inlet side of mixing boxes.
Flow indicators	Pipeline	*Pump return for hot and chilled water systems. *Each zone of multizone hot and chilled water systems.

2.2.8.3 Combination Instrument and Controls. Recording and indicating instruments shall be combined with control devices to measure conditions at the point of control.

2.2.8.4 Multi-Point Remote Indicators. Use multi-point remote indicators to check temperature, pressure, humidity, and other equipment operating conditions for areas remotely located from the central control point. With large installation, it can be advantageous and economical to provide multi-point remote indicators at a central supervisory location instead of having several indicating type instruments installed at different spaces.

2.2.8.5 Control Board. Instruments and controls in one space shall be combined on a single control board and arranged for rapid readout. Locate control boards for walk-up access.

2.2.8.6 Desired Instrumentation Characteristics

a) Range. The instrumentation range shall be such that under normal operating conditions, the indicating pointer will remain vertical. Variations in operating conditions shall occur within the middle one-third of the range.

b) Compensation. Specify self-compensating instruments which are not affected by external changes in temperature or pressure. Provide surge protection for pressure gages.

c) Over-Temperature Alarms. Include over-temperature alarm signal system in electronic equipment facilities not having continuous occupancy during operation. This system shall consist of at least one cooling-type thermostat in the electronic equipment room, and an audio alarm in the occupied control center. For normal operations, set the thermostat to activate the alarm when the facility temperature reaches 90 degrees F. Alarm circuit activation at lower temperatures can be used if dictated by electronic equipment requirements.

d) Thermometers. Thermometer wells can be used in lieu of fixed permanent thermometers. Table 2 provides typical locations for thermometers in piping systems.

e) Pressure Gages. Pressure gage tappings with cocks can be used in lieu of fixed, permanent pressure gages. Provide pressure gages as indicated in Table 2.

2.2.9 Metering. Comply with NAVFAC Maintenance and Operation Manual (MO)-209, Maintenance of Steam, Hot Water, and Compressed Air Distribution Systems, MO-220, Maintenance and Operation of Gas Systems, and MO-230, Maintenance Manual Petroleum Fuel Facilities. For Air Force projects, comply with Air Force Engineering Technical Letter (ETL) 94-2, Utility Meters in New and Renovated Facilities. Meter new buildings to monitor energy consumption, verify proper system operation, and validate results of energy analysis and savings.

#### 2.2.10 Piping Systems

2.2.10.1 Sizing. Pipe sizing and maximum pipe velocities shall be in conformance with ASHRAE Handbook, Fundamentals. Refer to Section 7 for additional information on design of piping systems.

2.2.10.2 Pipe Expansion. Preferred methods of accommodating thermal expansion is by pipe geometry, e.g., offsets and changes in direction, and by pipe loops. Use expansion joints only when space does not permit proper geometry or installation of pipe loops.

#### 2.2.11 Duct System Design

##### 2.2.11.1 HVAC Systems

a) Duct Sizing. ASHRAE Handbook, HVAC Systems and Applications offers three methods of sizing duct system; the equal friction method; the static regain method; and the T-method. The designer shall choose the method that he thinks is most appropriate for the particular system, and then design

according to ASHRAE Handbook, HVAC Systems and Applications. The static regain method should be used for sizing supply ducts in a VAV system (refer to Section 6 and Appendix C for additional information). Minimum rectangular duct size is 6 inches by 6 inches and minimum round duct size is 4 inches diameter. Round duct is preferred because of reduced noise, pressure loss, and leakage. In general, try to size low velocity ducts in a range of .05 to .08 inch static pressure drop per 100 linear feet of ductwork. For large duct systems, the designer should iterate the design by doing optimization to ensure lowest life cycle cost. Additional information on duct design is given in Section 6. For industrial ventilation duct design, refer to MIL-HDBK-1003/17, Industrial Ventilation Systems.

b) HVAC Duct Construction. Duct construction shall follow Sheet Metal and Air Conditioning Contractors' National Association (SMACNA) standards. On drawings, note the SMACNA pressure, seal, and leak classifications required. In specifications, note the duct tests required. See Figure 10 for preferred method.

2.2.11.2 Restriction on Use of Ductwork. Do not use underground ductwork because of health risks associated with soil-incorporated termiticides such as chlordane and with soils containing radon gas. In addition, the following ductwork construction is prohibited:

- a) Sub-slab or intra-slab HVAC system ducts.
- b) Plenum type sub-floor HVAC systems, as defined in the Federal Housing Administration (FHA) minimum acceptable construction criteria guidance.
- c) HVAC ducts in contact with the ground within an enclosed crawl space.
- d) Other HVAC systems where any part of the ducting is in contact with the ground.

2.2.12 Industrial Ventilation and Exhaust Systems. For design of industrial ventilation and exhaust systems, use the following as appropriate: American Conference of Governmental Industrial Hygienists (ACGIH) Handbook, Industrial Ventilation - Manual of Recommended Practice; and MIL-HDBK-1003/17, Industrial Ventilation Systems. If the system conveys vapors, gases, or smoke; use the equal friction or static regain method for design. If the system transports particulates, then velocities shall be sufficient to transport the particles.

2.3 Noise and Vibration Control. For noise and vibration control, refer to Army TM 5-805-4, Noise and Vibration Control for Mechanical Equipment, Chief of Naval Operations Instruction (OPNAVINST) 5100.23, Navy Occupational Safety and Health (NAVOSH) Program Manual, and ASHRAE Systems Handbook. Limit HVAC and ancillary equipment noise levels below those requiring a hearing conservation program as defined in Department of Defense Instruction (DODINST) 6055.12, DOD Hearing Conservation Program.

2.4 System and Equipment Performance. Refer to MIL-HDBK-1190, Facility Planning and Design Guide. For size and selection criteria of systems and equipment, refer to ASHRAE Equipment Handbook. HVAC systems shall be able to dehumidify supply air under loading conditions, provide reliable operations, and tolerate reasonable variations in chilled-water temperatures. Air conditioning systems generally operate at part load conditions most of the time. This is particularly true of comfort air conditioning systems which often operate at less than 50 percent of their design load capacity for more than 50 percent of the time. Since high part load efficiencies are desirable to conserve energy, the selection of equipment and step starting and sequencing controls shall be made with an emphasis on reducing life-cycle costs at part load conditions. Verify and document the equipment operation in accordance with ASHRAE Guideline 1, Commissioning of HVAC Systems.

#### 2.4.1 Cooling Systems

2.4.1.1 Central Air Conditioning Systems. Use these systems for applications where several spaces with uniform loads will be served by a single apparatus and where precision control of the environment is required. Cooling coils can be direct expansion or chilled water. Select air cooled or evaporative condensers, cooling towers, and ground-loop systems based on life cycle economics considering operating efficiencies and maintenance costs associated with outdoor design conditions and environment, e.g., high ambient temperatures and dusty conditions could adversely impact the operation of air cooled condensers. Consider temperature rise of chilled water supply when selecting chilled water coils, especially for applications requiring precision humidity control.

2.4.1.2 Unitary Air Conditioning Systems. These systems should generally be limited to loads less than 100 tons. Unitary systems are packaged in self-contained or split configurations. Self-contained units incorporate components for cooling or cooling and heating in one apparatus. Thermostatic expansion valves are preferred over capillary tubes and orifices for refrigerant control when available as a manufacturer's option

since expansion valves provide better superheat control over a wide range of operating conditions. Split systems may include the following configurations:

- a) Direct expansion coil and supply fan combined with a remote compressor and condensing coil; or
- b) Direct expansion coil, supply fan, and compressor combined with a remote condenser, cooling tower, or ground-loop system.

These systems generally have lower first cost than central systems but may have higher life cycle costs. If part load operation is anticipated for a majority of equipment operating life, consider multiple unitary equipment for superior operating efficiencies and added reliability. Refer to ASHRAE Handbook, Equipment for size and selection criteria.

2.4.1.3 Room Air Conditioning Units. These units are self-contained units serving only one space. These units are typically referred to as window or through-the-wall type air conditioners. Rooms served by these units should have a separate HVAC unit to provide ventilation air for a group of rooms. Use them when they are life cycle cost effective, and in accordance with MIL-HDBK-1190. Refer to ASHRAE Equipment Handbook.

2.4.1.4 Built-up Systems. These systems consist of individual components assembled at the building site. Generally, use them when a large volume of air is handled. These systems may be used as remote air handling systems with a central cooling plant. They are generally more efficient and better constructed than unitary air handling units. Determine the number of air handling units by an economic division of the load, considering: (a) the value of space occupied by equipment; (b) the extent of ductwork and piping; (c) the multiplicity of control, maintenance, and operating points; and (d) energy conservation factors.

2.4.2 Heating Systems. Heating sources can be either steam, hot water, natural gas, oil, electricity, or a renewable resource. Select these sources based on life cycle cost. Heating systems may be combined with ventilating systems when feasible. Heating-dominated climates require perimeter radiation at windows in office spaces.

2.4.2.1 Individual Heating Plants. Locate individual heating plants in the building they serve or in a separate, adjoining building.

2.4.2.2 Central Heating Plants. Refer to MIL-HDBK-1003/6. Base the total heating system capacity on normal demand rather than total connected load.

2.4.2.3 Snow Melting Systems. Provide snow melting systems to maintain an access area free of snow and ice for such areas as hospital entrances and hangar doors.

2.4.3 All-Air Systems. Refer to ASHRAE Systems Handbook. In humid climates, provide all-air systems for air conditioning. These systems are central systems which provide complete sensible and latent heating and cooling of the air supply. These systems are either single path or dual path. Single-path systems have heating and cooling elements in a series configuration. Dual-path system elements are arranged in parallel. Consolidation of system components at a central location provides increased opportunity for energy conservation.

2.4.3.1 Constant-Volume Systems. Use where room conditions are to be maintained by supplying a constant volume of air to the space and varying supply air temperature in response to demands for net space heating or cooling.

a) Applications. In addition to multi-zone systems, this includes single-zone or single-space applications in auditoriums, meeting rooms, cafeterias, restaurants, and small retail stores.

b) Multi-zone Systems. Use these systems to provide individual temperature control of a small number of zones, maximum 10 zones, from a central air handler. For normal comfort cooling applications, place cooling and heating coils in the air handler. For applications where humidity control is critical, place coils in series so that air is conditioned by the cooling coil prior to passing to the hot deck. Provide cooling by direct-expansion or chilled-water coils. Provide heating by steam coils, hot water coils, or electric coils.

c) Terminal Reheat Systems. These systems overcome zoning limitations by adding individual heating coils in each zone's branch duct to compensate for areas of unequal heating load. Heat, whether in the form of hot water, steam, or electrical resistance heaters, is applied to either preconditioned primary air or recirculated room air.

(1) These systems waste energy because supply air is cooled to a low enough temperature to serve the zone needing the coolest air, but then supply air must be reheated for other zones to avoid overcooling. Where constant volume is maintained,

the waste of energy can be even more significant. Reset cold deck temperature to meet cooling requirements of the room with the largest load or to satisfy humidity requirements. This cold deck temperature control reduces energy consumption.

(2) Due to high energy consumption, limit these systems to applications requiring close control of temperature and humidity, such as hospital intensive care areas and laboratories. When economically feasible, use heat recovered from the refrigeration cycle in heating coils.

2.4.3.2 Variable Air Volume (VAV) Systems. Use VAV systems for buildings with sufficient zones (11 or more zones) and load variation to permit reduction of fan capacity for significant periods during the day. Do not use bypass VAV systems. The complexity of systems should be consistent with minimum requirements to adequately maintain space conditions. For more information, refer to Section 6 and Appendix C.

2.4.3.3 Economizer Cycle. Obtain approval of the EFD or EFA for use of the economizer cycle. The economizer cycle should not be used in humid climates and for spaces where humidity control is critical, such as computer rooms. Problems have been experienced with linkage corrosion, excessive damper leakage, jammed linkage on large dampers, and inadequate maintenance. Outdoor air dampers should be located away from the intake louver and after duct transition to minimize exposure to weather and size of dampers. Provide outdoor air dry bulb changeover rather than enthalpy or outdoor air/return air comparator changeover. Pars. 6.3, 8.2, 8.3, 8.4, and 8.5 provide additional information on the economizer cycle.

With VAV systems, return or relief fans shall not be used. An economizer should only be used when it can be designed with gravity relief through the building envelope. Size gravity relief dampers to prevent building over pressurization. Refer to Section 6 and Appendix C for additional information.

#### 2.4.4 Duct, Pipe, and Equipment Insulation

a) Refer to NFGS-15250, Mechanical Insulation for guidance on design and selection of insulation systems.

b) Refer to MIL-HDBK-1011/1 for special requirements in humid climates.

2.4.5 Computer Programs for Load Calculation. For input characteristics of computer programs, refer to MIL-HDBK-1190. Use ASHRAE procedures, hourly weather data or bin method, and



part load equipment performance data. Demonstrate full and part load equipment and system performance in the load calculation. The following computer programs may be helpful in load calculation:

a) Building Loads Analysis and System Thermodynamics (BLAST). The BLAST computer program is used to predict energy consumption, energy system performance, and energy cost in buildings. This program computes hourly space loads, mechanical and electrical power consumption, power plant fuel consumption, and life-cycle costs. This program may be obtained by contacting BLAST Support Office, Department of Mechanical Engineering, University of Illinois, 1206 West Green Street, Urbana, IL 61801; telephone 1-800-UI-BLAST. This program is funded by the U.S. Army Corps of Engineers. If used by Federal agencies, this program is free of charge.

b) Commercial Programs. Computer programs for HVAC and dehumidifying systems are commonly available from computer software companies or air conditioning manufacturers.

2.5 Mechanical Room Ventilation. Provide ventilation systems for mechanical equipment rooms to limit temperature rise due to heat release from piping and equipment. Size fans based on a 10 degree temperature rise above the outdoor dry bulb temperature design condition; provide thermostat control of fans. Design ventilation systems for equipment rooms containing refrigeration equipment in accordance with ASHRAE Standard 15, Safety Code for Mechanical Refrigeration including refrigerant or oxygen deprivation sensors (based on the classification of refrigerant) and alarms, to ensure safe refrigerant concentration levels. Pipe refrigerant discharges from pressure relief devices, rupture members, fusible plugs, and purge units directly to the exterior of the building.

2.5.1 Self-Contained Breathing Apparatus (SCBA). Do not provide SCBA for mechanical refrigeration rooms, unless there will be a full time standing watch in the room. Provide, and maintain current, SCBA training for watchstanders, where there is a full time standing watch.

a) The fire department or hazardous material spill response team answering an alarm call will have SCBA available. If they need assistance in securing any equipment, they will be able to outfit the refrigeration mechanic with SCBA and provide trained escorts to accompany the refrigeration mechanic into the hazardous atmosphere.

b) It is too dangerous to allow untrained personnel to don SCBA equipment and venture into a known hazardous atmosphere. For that reason, the Navy has elected not to provide the SCBA, since there would be no control over who might don the SCBA and attempt to enter the room.

2.6 Radon Mitigation Systems. The following components of a sub-slab depressurization system should be included in the design for buildings which will be constructed on sites known or suspected of being a source of radon gas and which will be occupied more than 4 hours a day:

a) Piping. Provide one 3-inch diameter polyvinyl chloride (PVC) pipe (Schedule 20) through the floor slab for every 1,000 square feet of slab area located as close to the center of the area as possible. See Figure 1 for floor penetration detail. Pipe should extend through the building roof, concealed in partitions, closets, store rooms, etc. An adequate length of straight vertical piping should be provided in the ceiling space below the roof for future installation of the depressurization fan if post construction testing indicates excessive radon levels. Locating the fan near the roof or ceiling establishes a negative pressure in the piping system thereby minimizing potential of leaks in occupied spaces. Crack between pipe and slab should be sealed with polyurethane caulk. Evaluate the economic feasibility of combining several PVC pipes to reduce the number of risers and the number of roof penetrations, especially for multi-story buildings.

b) Electrical Requirements. Provide a 110 volt, 15 ampere electrical power supply terminating at convenient locations near the location for the future depressurization fans in PVC pipe. Ensure convenient access to locations selected for future installation of depressurization fans.

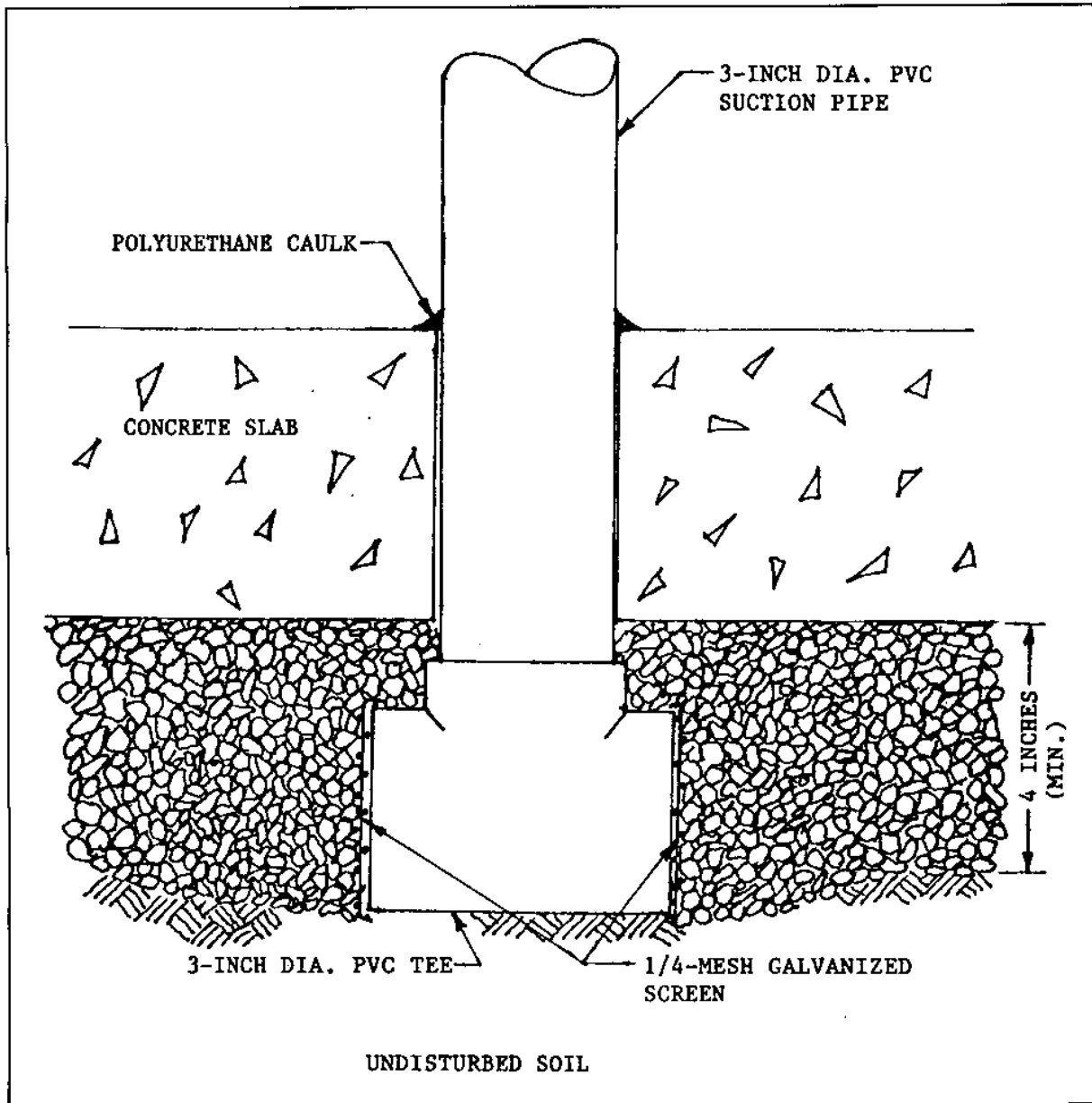

Figure 1  
Floor Penetration for Sub-Slab Depressurization System

Section 3: APPLICATIONS

3.1 General. Criteria applicable to specific building types are listed in Table 3. These criteria apply when specific requirements are not addressed in this handbook.

3.2 Building Types. MIL-HDBK-1190 is the highest ranking Navy design criteria, followed by NAVFAC design manuals and NAVFAC military handbooks. Refer to the EFD or EFA A-E Guide for (local) submission requirements. Refer to ASHRAE handbooks for design guidance not shown in Navy criteria.

3.3 Air Force Projects. Air Force criteria shall govern when different from Navy criteria.

3.4 Tropical Engineering. Refer to MIL-HDBK-1011/1 for additional design guidance. Some of the problems encountered with HVAC systems in the tropics are:

- a) Corrosion of equipment.
- b) Damage by windblown debris and windblown rain.
- c) Humidity control. Comfort cooling systems require cooling of outside air the year around to control humidity.
- d) Special pipe insulation and vapor barriers.
- e) Damper mechanisms tend to jamb due to corrosion.

3.5 Electronic Facilities. Building types include:

- a) Receiver buildings
- b) Telephone and switchgear rooms
- c) Radio direction-finder facilities
- d) Uninterrupted power supply (UPS) rooms
- e) Transmitter buildings
- f) Computer rooms
- g) Control towers
- h) Transportable/tactical facilities
- I) Transportable/relocatable facilities

- j) Permanent facilities
- k) Transportable, non-relocatable facilities

Table 3  
Applicable Criteria by Building Type

Building Type	Category Codes	Navy Criteria	Other Guides/ Standards	Special Considerations
(All)	(Varies)	MILHDBK-1190, NAVFAC P-89, & MILHDBKs	ASHRAE Hdbk Series	See 3.2
		A-E Guide	NFPA Codes	
		OSHA 1910		
		A-E Contract PED (DD-1391)	Local & Regional Bldg Codes	
		Local Station Smoking Regs		
USAF Projects	(Varies)	Current USAF/ LEEE, ETLs, AFMs, USAF Regional Civil Engineer General Design & Construction Guidance MILCON Program	(Varies)	See 3.3
		Plus Navy Criteria		
Tropical Engineering	(Varies)	MILHDBK-1011/1		See 3.4
Clean Rooms	(Varies)	MILHDBK-1028/5		See Navy Criteria

Table 3 (Continued)  
Applicable Criteria by Building Type

Building Type	Category Codes	Navy Criteria	Other Guides/ Standards	Special Considerations
High Altitude Electro-Magnetic Pulse Protection for Ground-Based Facilities	(Varies)	MILHDBK-423		See Navy Criteria
Electronic	(Varies)	MILHDBK-1012/1		See 3.5
Computer Rooms in Electronic Facilities	(Varies)	MILHDBK-1012/1		See Navy Criteria
Satellite Communication Ground Station (this is an electronic facility)	131	MILHDBK-1012/1	MIL-STD-210 NAVELEX 0101, 105	See Navy Criteria
Navigation & Traffic Aids	133 137	NAVAIR 51-50AAA-2		See Navy Criteria
Airfield Lighting	136	MILHDBK-1023/1		See Navy Criteria
USMC Cryogenics Facility	141	NAVFAC P-272		See Navy Criteria
Air Passenger Terminal	141-11	NAVFAC P-272		See Navy Criteria

Table 3 (Continued)  
Applicable Criteria by Building Type

Building Type	Category Codes	Navy Criteria	Other Guides/ Standards	Special Considerations
Air Cargo Terminal	141-12	NAVFAC P-272		See 3.6
Courier Station	141-13	TM 5-844 NAVFAC P-360		See Navy Criteria
Aircraft Fire & Rescue Station & Structural/ Aircraft Fire & Rescue Station	141-20	MILHDBK-1008B MILHDBK-1028/1 MILHDBK-1028/6		See Navy Criteria
Aircraft Line Operations Bldg	141-30	NAVFAC P-272		See 3.7
Aircraft Operations Bldg	141-40	NAVFAC P-272		See Navy Criteria
Photo-graphic Bldg	141-60	NAVFAC P-272		See 3.8
Fleet Reconnaissance Photo-graphic Lab	141-65	NAVFAC P-272		See Navy Criteria
NAS Control Twr (this is an electronic facility)	141-70	MILHDBK-1012/1  NAVELEX 0101, 107  NAVFAC P-272		See 3.9

Table 3 (Continued)  
Applicable Criteria by Building Type

Building Type	Category Codes	Navy Criteria	Other Guides/ Standards	Special Considerations
Liquid Oxygen/Nitrogen Facilities	141-87	NAVFAC P-272  MILHDBK-1024/3		See 3.10
Helium Plant & Storage	142-10 142-19	MILHDBK-1024/2  29 CFR 1910.94		See Navy Criteria
Armory for Fleet Marine Force (FMF) Air Group Squadron	143-45	NAVFAC P-272		See Navy Criteria
Explosive Ordnance Disposal (EOD) Team Facilities	148-20	NAVFAC P-272		See Navy Criteria
Aircraft Fixed Point Utility Systems	149	MILHDBK-1028/6		See Navy Criteria
Maintenance Facilities for Ammunition Explosives & Toxics	200	MILHDBK-1028/3  NAVSEA OP 3368 & NAVSEA OP 5		See 3.11
General Maintenance Facilities	210	DM-28.4	ACGIH Industrial Ventilation - Manual of Recommended Practice  NFPA 33	See 3.12



Table 3 (Continued)  
Applicable Criteria by Building Type

Building Type	Category Codes	Navy Criteria	Other Guides/ Standards	Special Considerations
Aircraft Maintenance Facilities	211	MILHDBK-1028/1		See Navy Criteria
Shipyard Maintenance Facilities	213	MILHDBK-1028/5 DM-28.4 OSHA	ACGIH Industrial Ventilation - Manual of Recommended Practice	See Navy Criteria
Hospital Dental & Medical Facilities	500-550	MILHDBK-1191	NFPA codes including NFPA 101  JCAH Stds ASHRAE Hdbks	See 3.13
Admin Facilities	610	MILHDBK-1034		See Navy Criteria
Family Housing	710	MILHDBK-1035 FHA Minimum Property Std		See 3.14
Bachelor Enlisted Quarters	721	MILHDBK-1036		See 3.15
Bachelor Officer Quarters	724	MILHDBK-1036		See 3.16
Swimming Pool	740-53	DM-37.1		See Navy Criteria

Table 3 (Continued)  
Applicable Criteria by Building Type

Building Type	Category Codes	Navy Criteria	Other Guides/ Standards	Special Considerations
Industrial Ventilation	(None)	MILHDBK-1003/17		See 3.17
Energy Conservation	(None)	MILHDBK-1190		See Navy Criteria
Kitchen Ventilation				See 3.18
Laundry				See 3.19

- l) UPS and microwave equipment battery rooms
- m) Emergency generator rooms
- n) Satellite communication ground stations
- o) Shielded enclosures
- p) Automated data processing (ADP) centers
- q) Oceanographic facilities

3.6 Air Cargo Terminal. Provide climate control in offices and computer room. Provide for chilled water cooling of equipment as required.

3.7 Aircraft Line Operations Building. When heating is required for movable structures, provide small oil-fired room heaters bearing the label of Underwriters' Laboratories, Inc. (UL) where required. Electric heat may be considered as a more economical alternative.

3.8 Photographic Building. Ensure that ventilation provided in the color film processing room is adequate to remove heat and fumes from equipment. Fresh air intake and interior return vents shall be filtered and ventilation shall produce minimum air movement (approximately 15 feet per minute) to prevent agitation of settled dust. Design exhaust ventilation

system for chemical mixing room to maintain air in the breathing zone free of chemicals. (Refer to Section 2 of MIL-HDBK-1003/17 for recommended design procedures.) The exhaust fan and venting of automatic processing equipment shall not re-introduce exhaust fumes into the fresh air intake.

3.9 Naval Air Station Control Tower. Remote transmitters and receivers associated with towers usually require air conditioning. If remote buildings are associated with towers, provide a central alarm system for out-of-service conditions such as high temperature. Forced ventilation or air conditioning shall be provided for the control cab for personnel comfort and for electronic equipment rooms to meet temperature and humidity requirements of electronic equipment. Conduct a thorough analysis of the solar heat gain to ensure proper sizing of the cooling equipment. Provide for manual adjustment of thermostats to control air conditioning by control cab occupants. Provide for emergency ventilation for the control cab utilizing the air conditioning supply duct.

3.10 Liquid Oxygen and Nitrogen Facilities. Design ventilation systems to provide personnel comfort and adequate removal of fugitive gas emissions.

3.11 Maintenance Facilities for Ammunition, Explosives, and Toxics. These facilities include:

- a) General ammunition maintenance shops
- b) Bomb-type ammunition maintenance shops
- c) Propellant powder maintenance shops
- d) Air and underwater weapons shops
- e) Quality evaluation laboratory

3.12 General Maintenance Facilities. Building types include:

- a) Motorized vehicle maintenance
- b) Transportation refueled repair
- c) Construction and weight handling equipment
- d) Railroad equipment
- e) Marine Corps motor vehicle maintenance

- f) Weapons maintenance
- g) Electronic and communication maintenance
- h) Container repair and test
- I) NFESC Drum reconditioning
- j) Mechanical equipment calibration
- k) Aircraft ground support equipment
- l) Ground support equipment holding
- m) Battery shop
- n) Public works maintenance

Refer to 29 CFR 1910.94, .106, .107, and .108 for ventilation requirements related to specific operations, e.g., abrasive blasting, painting, buffing and grinding, dip tanks, and chemical storage.

3.13 Hospital, Dental, and Medical Facilities. Military Standard (MIL-STD)-1691, Construction and Material Schedule for Military Medical and Dental Facilities provides utility requirements for medical equipment to assist in determining heat gains, ventilation requirements (e.g., fume hood exhaust), and steam connections (e.g., sterilizers).

3.14 Family Housing. Provide access for maintenance of mechanical equipment and devices. For safety, protect mechanical spaces and equipment with strong door catches or shielding from moving parts and controls. Provide ducted exhaust fans with backdraft dampers for kitchens and interior bathrooms. Size bathroom fans for 10 air changes per hour minimum; kitchen exhaust fans for 15 air changes per hour minimum or 50 cubic feet per minute per linear foot of range hood. Refer to MIL-HDBK-1035, Family Housing for requirements on attic exhaust fans, evaporative cooling, and air conditioning.

3.15 Bachelor Enlisted Quarters. Refer to MIL-HDBK-1036, Bachelor Quarters for procedures to calculate heating and cooling loads, equipment sizing, and design recommendations; except that ventilation requirements shall be in accordance with ASHRAE Standard 62.

3.16 Bachelor Officer Quarters. Refer to MIL-HDBK-1036 for procedures to calculate heating and cooling loads, equipment sizing, and design recommendations; except that ventilation requirements shall be in accordance with ASHRAE Standard 62.

3.17 Industrial Ventilation. The scope of this handbook is limited to HVAC systems. Refer to MIL-HDBK 1003/17 and ACGIH Industrial Ventilation - Manual of Recommended Practice. Design for sufficient makeup air for buildings with industrial ventilation exhaust systems to limit building negative pressure to 0.05-inch water gage. Introduce air into spaces with exhaust hoods at low velocities to prevent interference with hood performance. Treat air exhausted outdoors to conform with local and Federal emission standards.

3.18 Kitchen Ventilation. Outdoor air supplied to the dining area shall be used as kitchen makeup air. If kitchen exhaust air volume exceeds dining area outdoor air requirements, additional air shall be supplied directly into the kitchen. Outdoor air supplied directly to the kitchen shall be filtered and heated, and introduced horizontally at or near the ceiling to provide mixing without directly causing drafts at cooking levels or on kitchen personnel. The minimum ventilation rate for non-air conditioned kitchens is 30 air changes per hour in temperate zones. The minimum in the tropics or semi-tropics is 60 air changes per hour. Air exhausted through range and kettle hoods is considered part of the kitchen ventilation system.

Refer to MIL-HDBK-1190 for guidance in the application of air conditioning. Air volume supplied during the heating season to air conditioned kitchens shall be limited to volume required by various hoods. In air conditioned kitchens, design the supply system so that hoods exhaust primarily unconditioned air and recirculation of kitchen odors is minimized. Also, evaluate the feasibility of evaporative cooling in lieu of air conditioning. In non-air conditioned kitchens, design the supply system for cross ventilation.

3.18.1 Kitchen Equipment Exhaust Hoods. Provide grilles, ovens, ranges, kettles, and dishwashers with exhaust hoods, and a means for precipitating and disposing of grease where applicable. Hoods shall be capable of extracting grease using centrifugal force. Exhaust systems shall conform to NFPA 96, Ventilation Control and Fire Protection of Commercial Cooking Operations.

3.18.2 Exhaust Systems. Fan motors for exhaust systems in kitchen, dining, and related areas shall be located out of the air stream. Do not locate volume dampers or splitters between the hood and fan. Duct velocity shall range between 1500 and

1700 feet per minute to maintain particulate matter in suspension. Provide accesses for cleaning ducts without dismantling.

3.18.3 Fire Protection. Refer to MIL-HDBK-1008B, Fire Protection for Facilities Engineering, Design, and Construction. Ranges, ovens, broilers, deep-fat fryers and other appliances that present fire hazards shall have exhaust hoods, ducts, and fans. Install high-limit thermostats in exhaust ducts as near as possible to the hood to protect the hood exhaust system from grease fires. For more information, refer to ASHRAE Handbook. Exhaust fans for hoods with dry chemical extinguishing systems shall remain on when the extinguishing system is activated. Similarly, exhaust hood and ductwork dampers shall remain open when the extinguishing system is activated. For other types of extinguishing systems, the fan shall be turned off.

An easily accessible, independent and well identified manual switch shall be provided for the fire extinguishing system of each hood. Do not install volume control dampers in range and kitchen hood exhaust ductwork, but provide a fire damper in the outlet, except in ductwork with extinguishing systems. In addition, provide an automatic hood cleaning system.

3.18.4 Calculation of Exhaust Hood Air Volume Rate. To calculate actual exhaust rate required for kitchen equipment exhaust hoods, apply the following procedure:

a) Determine, for each item of kitchen equipment, the equipment type, fuel type, and ventilator type; and determine the equipment width, depth, and surface area, including work tables from the kitchen equipment plan requirements.

b) Select the appropriate thermal current velocity from Table 4 for each piece of equipment.

c) Select the appropriate safety factor from Table 5 for each item of equipment.

d) Calculate the duty group cfm per foot of width for each item of equipment by multiplying the equipment area times the thermal current velocity times the safety factor, and divide the result by the equipment width.

e) Classify each item of equipment into its duty group in accordance with Table 6, and assign the appropriate standard air volume rate for each item of equipment.

f) Calculate the total kitchen exhaust airflow for each item or equipment by multiplying each assigned standard air volume rate times the width of its respective item of equipment.

g) Add the total exhaust airflow for each item of equipment located beneath an individual kitchen hood, to determine the hood required airflow quantity.

Provide a table of calculations for the kitchen equipment exhaust hoods in the design calculations; include the data and calculations from the above subparagraphs a) through g).

Table 4  
Thermal Currents Charts

Equipment	Approximate Surface Temperature (Degrees F)	Thermal Current Velocity (Feet Per Minute)	
		ELECTRICITY	GAS
Dishwashers, Ovens, Steamers, and Kettles	210	20	25
Braising and Pans	150	30	50
Chicken Broaster	350	35	55
Fryers	375	35	60
Griddles and Ranges	375	35	40
Hot Top Ranges	800	85	100
Salamanders, High Broilers	350	60	70
Grooved Griddles	500-600	65	75
Charbroilers	600-750	75	175
Broilers (Live Charcoal)	1500	--	200
Work Tops, Spreaders, etc.	--	5	5

Table 5  
Safety Factor Chart

Ventilator Type	Multipliers
Backshelf	1.05
Passover	1.15
General All-Purpose	
Wall Mount: End Closed	1.05
End Open	1.20
Island Style: Single	1.50
Double	1.30

Table 6  
Duty Group Chart

Group	Range (cfm/ft)	Standard Air Volume (cfm/ft)
Light Duty	0 to 150	150
Standard Duty	151 to 250	250
Heavy Duty	251 to 300	300
Extra Heavy Duty	301 to 400	400

3.18.5 Exhaust Hood Heat Recovery. Heat recovery for kitchen exhaust hoods should only be considered for commercial size kitchen when life cycle cost effective and when building design cannot meet the energy budget. Manufactured heat recovery modules for commercial size kitchen hoods are available. These modules typically use a heat pipe method of heat recovery, but several configurations are available. Also, heat exchanger equipment should be located at ground level for easy access to inspect, maintain, and remove for shop cleaning. The key variable for heat recovery feasibility is hours of operation. An intermittently used exhaust may not have sufficient operating hours for heat recovery to be cost effective.



3.18.6 Air Curtains. Air curtains designed as fly screens shall be provided on exterior entrances to food preparation areas, but they shall not be required if the entrance is to be used only as an emergency exit. When air curtains are mounted in locations significantly above normal door heights, curtain air velocities and noise levels shall be verified by the designer. Evaluate the feasibility of using air curtains for conditioned area openings to loading docks or similar service areas. For more information, refer to ASHRAE Handbook series.

### 3.19 Laundries

a) Due to high heat releases from processing equipment, laundries generally do not require space heating systems where minimum ambient winter temperature is above 50 degrees F. For lower ambient temperatures, provide unit heaters to maintain space temperatures above 40 degrees F during unoccupied periods. Unit heaters can be direct fuel fired (vented) type or steam or hot water coil type.

b) Ventilation cooling is generally required year around during occupied periods. Provide 30 air changes per hour for temperate zones and 60 air changes per hour in tropic and semi-tropic zones. For winter design temperatures below 50 degrees F, ventilation air should be tempered. If life cycle cost effective, heat recovery from exhaust air is the preferred method of tempering makeup air using one of the systems illustrated in Figures A-4 through A-8. Other acceptable methods of tempering include direct fired duct heaters and steam or hot water coils with full flow through the coils and face and bypass dampers for temperature control. Provide a low limit thermostat in the discharge from the coil to stop the fan for freeze protection.

c) Spot cooling can be provided for fixed stations such as ironers, presses, and mangles. Evaporative cooling can be an effective means of cooling air in most geographic areas. Consider supplying air at the operator's feet with air distribution below a raised platform; provide individual operator control of air supply.

d) Provide clothes dryer vents independent of other exhaust systems. Include a makeup system for systems exhausting more than 200 cubic feet per minute. If the exhaust duct exceeds the manufacturer's recommended length, provide a fan sized for maximum cubic feet per minute of dryer(s). Specify galvanized steel or aluminum exhaust ducts without fasteners that could trap lint. Limit duct velocity to 2000 feet per minute. Calculate fan static pressure from the point of the most distant vent connection to the exhaust duct to the exhaust air discharge. Provide access in the duct for cleanout every 10 feet and at the bottom of vertical risers. Provide a backdraft damper without bird or insect screen at the exhaust air discharge. Locate the fan out of the exhaust air stream. Interlock the exhaust fan (and makeup air system if provided) to operate when any dryer operates.

## Section 4: INFORMATION REQUIRED ON DRAWINGS

4.1 General. Drawings shall provide a clear presentation of system design, and shall include items noted in project specifications by such terms as "where indicated," "as shown," etc. Refer to the local A/E Guide for additional requirements. Provide complete details of equipment, systems, and controls on project drawings as follows:

4.1.1 Identification of Drawings. Ensure that the drawings list, sheet numbers, and sheet titles on mechanical sheets match exactly as shown on the cover sheet and in specifications.

4.1.2 Equipment Schedules. Provide schedules of mechanical equipment.

4.1.3 Duct Pressure Classifications. Include duct pressure classifications on drawings to ensure ducts meet SMACNA construction standards. Evaluate the effect of closed fire dampers on duct pressure when determining pressure classification; include pressure relief devices as required to limit pressure buildup. See Figure 10 for examples or follow SMACNA.

4.1.4 Riser Diagrams. Riser diagrams drawn to vertical scale should be provided for mechanical systems in multi-story buildings. These shall indicate size changes in vertical piping runs. See Figures 38 and 39 for examples.

4.1.5 Controls. Include schematics (control loops) and ladder diagrams (see Figures 33, 34, and 35 for examples), sequences of operation, and equipment schedules (see Tables 15, 16, and 17 for examples). Include the following information to the maximum extent possible without being proprietary:

a) The schematic should show control loop devices and permanent indicating instrumentation, including spare thermometer wells.

b) Schematic and ladder diagrams should show interface points between field installed HVAC control systems, factory installed HVAC control systems (e.g., chiller and boiler controls), fire alarm systems, smoke detection systems, etc.

c) The ladder diagram should show the relationship of devices within HVAC equipment (e.g., magnetic starters) and other control panels.

d) The equipment schedule should show information that the vendor needs to provide instrumentation with properly calibrated ranges; to select proper control valves and associated actuators; to adjust control system devices for sequencing operations; to configure controller parameters, such as setpoints and schedules; and to set the control system time clocks. Indicate control valve flow coefficient (Cv) and pressure drop for every control valve.

e) Locations of devices and instrumentation should be indicated. Provide space, access, lighting, and appropriate mounting heights to read the instrumentation and set control devices.

f) Provide electrical surge protection on HVAC control devices as required to protect the DDC and EMCS.

g) Each control system shall have a sequence of operation. The sequence of operation should be shown on drawings adjacent to the schematic. After a standard has been adopted by industry, provide graphical schematics for sequence of operation of DDC systems on drawings.

h) Provide an input and output schedule for DDC systems. Schedule shall include a description of the device, type of point, and any special requirements.

i) A commissioning procedure for temperature controls should be specified and should detail how the vendor will inspect, calibrate, adjust, commission, and fine tune each HVAC control system. Refer to par. 8.6.

j) Project specifications should specify the coordination of HVAC system balancing with the temperature control system tuning. Specifications should require that balancing be completed, the minimum damper positions be set, and the balancing report be issued before the control systems are tuned.

k) Project specifications should list submittal requirements for the vendor.

4.1.6 Maintainability. Lack of maintenance contributes to poor performance of most systems throughout the Navy's shore facilities. This is due primarily to poor working conditions brought about by lack of design detail on drawings to ensure an installation with adequate accessibility for ease of operation and maintenance. Equally important are drawings that clearly represent the intended system arrangement and describe system

operation. To preclude this in the future include the following on drawings:

a) Identification of floor area required to remove equipment components such as filters, coils, heat exchanger tubes, bearings, etc. In equipment rooms, require that floor space be identified by striping with yellow paint.

b) Equipment elevations and room sections to clearly identify equipment arrangement which provides sufficient access for equipment operation and maintenance.

c) Location of permanent ladders, catwalks, and platforms required to access and maintain overhead equipment. Minimize the use of elevated equipment wherever possible.

d) Use two dimensional pipe drawings (with dimensions indicated as necessary) for congested spaces to ensure that equipment and piping will be installed as intended with adequate personnel space available for operation and maintenance.

#### 4.1.7 Symbols and Abbreviations

4.1.7.1 General. Provide a list of symbols and abbreviations on the title sheet of the project. Use symbols and abbreviations that are common to the trade as contained in ASHRAE handbooks. For larger projects, each discipline may have their corresponding lists on the first sheet of their group of drawings.

4.1.7.2 Specifics. Limit symbols and abbreviations to items that are actually in the project. Limit abbreviations to items that occur more than once in the project.

4.1.8 Building Column Lines and Room Names. Ensure that building column lines and room names are identical to those shown on architectural drawings.

## Section 5: LOAD CALCULATIONS

5.1 General. Refer to par. 2.1.1.2 for the selection of outdoor and indoor design conditions. Manual procedures provided below for determining heating and cooling loads are generally only applicable to small systems (e.g., heating systems less than 200,000 Btu per hour and cooling systems less than 10 tons). Computer programs are available that will provide more precise load determinations and the time of day with the highest cooling load. The highest heating load is assumed to occur just before dawn; therefore, this should be considered in the design heating load.

5.2 Heating Load5.2.1 Transmission

$$\text{EQUATION: } Q = U * A * (T_i - T_o) \quad (1)$$

where:  $Q$  = Btu/hr heat loss by transmission,

$U$  = heat transfer coefficient (look this up in a handbook for your particular wall, floor, roof, etc.),

$A$  = area of the surface (wall, window, roof, etc.),

$T_i$  = inside design temperature, and

$T_o$  = outside design temperature.

Use this formula to compute heat transmission losses from each element of the building skin (e.g., walls, windows, roof, etc.). Note that attic and crawl space and ground temperature are different from outdoor temperatures.

5.2.2 Infiltration and Ventilation. To determine the heating load use the larger of the infiltration and ventilation loads. Outdoor air provided for ventilation should exceed the air exhausted by 10 to 15 percent to minimize infiltration. The designer must use judgment on the amount of excess supply air to include based on number and type of windows and doors.

$$\text{EQUATION: } Q = 1.10 * \text{CFM} * (T_i - T_o) \quad (2)$$

where: CFM = cubic feet per minute of outdoor air, and

$Q$  = the sensible heat loss, Btu/hr.

This section does not apply to industrial ventilation systems, e.g., systems to control fumes, vapors, and dust from such processes as plating, painting, welding, and woodworking. Refer to the MIL-HDBK-1003/17 and ASHRAE Handbook, HVAC Systems and Applications, for guidance on design of these systems. The EFD or EFA and the Naval Facilities Engineering Service Center (NFESC) can provide additional assistance.

5.2.3 Total Heating Load. Sum the transmission loads with infiltration and ventilation loads to get the total heating load. To this computed total heating load, add the following to size central equipment (do not apply these factors when sizing terminal equipment such as a finned-tube radiation, fan-coil units, etc.):

- a) Exposure factor (prevailing wind side) up to 15 percent.
- b) Pickup (for intermittently heated buildings with primary heat sources such as boilers, steam-to-water heat exchangers, etc.) 10 percent.
- c) Buildings with night setback. A residence with 10 degrees F setback requires 30 percent oversizing for acceptance pickup and minimum energy requirements.

5.3 Cooling Load. Computation of the peak cooling load can be a difficult effort. Heat gain is composed of or influenced by the conduction heat gain through opaque portions of the building skin; the conduction plus solar radiation through windows and skylights; the building internal loads such as people, lights, equipment, motors, appliances, and devices; and outdoor air load from infiltration. For sizing VAV systems, calculation of loads has more stringent requirements. Refer to Appendix C.

#### 5.3.1 Transmission

##### 5.3.1.1 Walls and Roof

$$\text{EQUATION: } Q = U * A * (T_o - T_i) \quad (3)$$

Refer to par. 5.2.1 for definition of terms.

##### 5.3.1.2 Glass

- a) Transmission

$$\text{EQUATION: } Q = U * A * (T_o - T_i) \quad (4)$$

b) Solar Heat Gain

EQUATION:  $Q = A * (SC * SHGF)$

where: SC = shading coefficient, and

SHGF = solar heat gain factor (look up the SHGF in a handbook (e.g., ASHRAE Handbook, Fundamentals) for each exposure and type of glass).

5.3.2 Infiltration and Ventilation

a) Sensible

EQUATION:  $Q_s = 1.10 * CFM * (T_o - T_i) \quad (5)$

b) Latent

EQUATION:  $Q_L = 4840 * CFM * W \quad (6)$

where: W = change in humidity ratio (lb water/lb air).

c) Ventilation Rates. Refer to ASHRAE Standard 62 or contact the EFD or EFA for ventilation requirements for spaces not listed below:

Auditoriums, theaters	15 cfm/person
Barracks (sleeping rooms)	15 cfm/person
Bedroom	30 cfm/room
Classroom	15 cfm/person
Communication centers	20 cfm/person
Conference rooms	20 cfm/person
Corridors	0.1 cfm/sq ft
Dining	20 cfm/person
Kitchens (commercial)	(refer to Section 3)
Lobbies	15 cfm/person
Locker, dressing rooms	0.5 cfm/sq ft
Lounges, bars	30 cfm/person
Offices (with moderate smoking)	20 cfm/person
Smoking lounge	60 cfm/person
Toilet, bath (private)	35 cfm/room
Toilet (public)	50 cfm/water closet or urinal

The total corrected outdoor air requirement for central systems supplying spaces with different ratios of outdoor-air-to-supply-air is determined from the following:

EQUATION:  $CFM_{ot} = Y * CFM_{st} \quad (7)$



where:  $CFM_{ot}$  = corrected total outdoor air quantity,  
 $CFM_{st}$  = total system airflow (i.e., sum of air supplied to all spaces), and

$Y$  = corrected fraction of outdoor air, or

EQUATION:  $Y = X / (1 + X - Z)$  (8)

where:  $X = CFM_{oa} / CFM_{st}$ ,

$Z = CFM_{oc} / CFM_{sc}$ ,

$CFM_{oa}$  = uncorrected sum of outdoor airflow rates for spaces on the system,

$CFM_{oc}$  = outdoor air required for critical space, and

$CFM_{sc}$  = supply air to the critical space. The critical space is that space with the greatest required fraction of outdoor air in the supply to that space.

d) VAV system ventilation issues. Refer to Appendix C.

5.3.3 Internal Loads

5.3.3.1 People Loads. Adjusted (normal male/female/child).

	Sensible	Latent
Office (seated light work, typing)	255 Btu/hr	255 Btu/hr
Factory (light bench work)	345 Btu/hr	435 Btu/hr
Factory (light machine work)	345 Btu/hr	695 Btu/hr
Gymnasium athletics	635 Btu/hr	1165 Btu/hr

5.3.3.2 Lights and Equipment

a) Lights

EQUATION:  $Q = 3.41 * W * F_{ul} * F_{sa}$  (9)

where:  $W$  = total light wattage,

$F_{ul}$  = use factor, and

$F_{sa}$  = special allowance factor for fluorescent fixtures or for fixtures that release only part of their heat to the conditioned space.

## b) Equipment

(1) Motors within conditioned space or within airstream.

$$\text{EQUATION: } Q = 2545 * \frac{HP}{E_m} * F_{lm} * F_{um} \quad (10)$$

where: HP = motor horsepower,

$E_m$  = motor efficiency,

$F_{lm}$  = motor load factor, and

$F_{um}$  = motor use factor.

(2) Appliances and equipment, such as business machines and computers. Refer to ASHRAE Handbook, Fundamentals or contact the EFD or EFA for assistance in determining sensible and latent heat gains from kitchen equipment.

$$\text{EQUATION: } Q_s = 3.41 * W * F_{ue} \quad (11)$$

where:  $Q_s$  = sensible load,

W = appliance wattage, and

$F_{ue}$  = equipment use factor.

## c) Heat Gain From Miscellaneous Sources

(1) HVAC Fan Motors (Outside the Airstream). Thirty-five percent of the input to an HVAC fan motor is converted to heat in the airstream because of fan inefficiency. Refer to par. 5.3.3.2 b)(1).

(2) HVAC Fan Motors (Within the Airstream). The motor load is converted to heat. Refer to par. 5.3.3.2 b)(1).

(3) Duct Leakage. Loss of supply air due to duct leakage shall be compensated by system capacity as follows:

(a) Well designed and constructed system: increase fan capacity by 3 percent.

(b) Poorly designed and constructed system: increase fan capacity by 10 percent.

## Section 6: AIR DISTRIBUTION

6.1 Duct Design for HVAC Systems

6.1.1 Sizing General. See Figure 2 for duct sizing. ASHRAE Handbook, Fundamentals recognizes three methods of sizing ductwork: the equal friction method, the static regain method, and the T-method. For design of small simple systems, the equal friction method will suffice. Use the static regain method for VAV design (refer to Appendix C).

6.1.2 Equal Friction Method Sizing. Select a constant pressure loss in inches of water per 100 foot length of duct from the preferred part of Figure 2. The preferred part of Figure 2 is between 0.08 and 0.6 inches of water per 100 feet friction loss for air quantities up to 18,000 cfm, and between 1800 fpm and 4000 fpm for air quantities greater than 18,000 cfm. Use low velocities and a low friction drop for small projects, or where ductwork is cheap and energy is expensive. For systems of 18,000 cubic feet per minute and over, use a friction loss of 0.08 and velocities of 1800 to 3000 feet per minute. After sizing the entire system at the selected unit pressure drop, go back and adjust velocities and pressure drops in the shorter branches to equalize the pressure drops at each duct branch junction. The designer must observe the recommended permissible room sound pressure levels for various applications discussed in NFGS-15895, Ductwork and Ductwork Accessories.

6.1.3 Ductwork General

6.1.3.1 Round Ducts. Use round ducts wherever possible. Under normal applications, the minimum duct size shall be 4 inches in diameter. Use smooth curved elbows as much as possible. If these are not available, use three-piece elbows for velocities below 1600 feet per minute and five-piece elbows for velocities above 1600 feet per minute. The throat radius shall not be less than 0.75 times the duct diameter.

6.1.3.2 Rectangular Ducts. Use a minimum duct size of 6 inches by 6 inches. Where possible, keep one dimension constant in transitions and do not make transitions in elbows. Make transitions in sides and bottom of the duct keeping top level to maintain maximum clearance above ceiling. The transition slope shall be 30 degrees on the downstream. Where ductwork is connected to equipment fittings such as coils, furnaces, or filters, the transition shall be as smooth as possible. Drawings shall indicate ductwork pitch, low spots, and means of disposing of the condensate. Elbows shall be smooth, with an inside radius of 1.0 times the width of the duct. Where space constraints

Reprinted by permission of American Society of Heating, Refrigerating, & Air-Conditioning Engineers, Inc., Atlanta, GA from ASHRAE Handbook, Fundamentals.

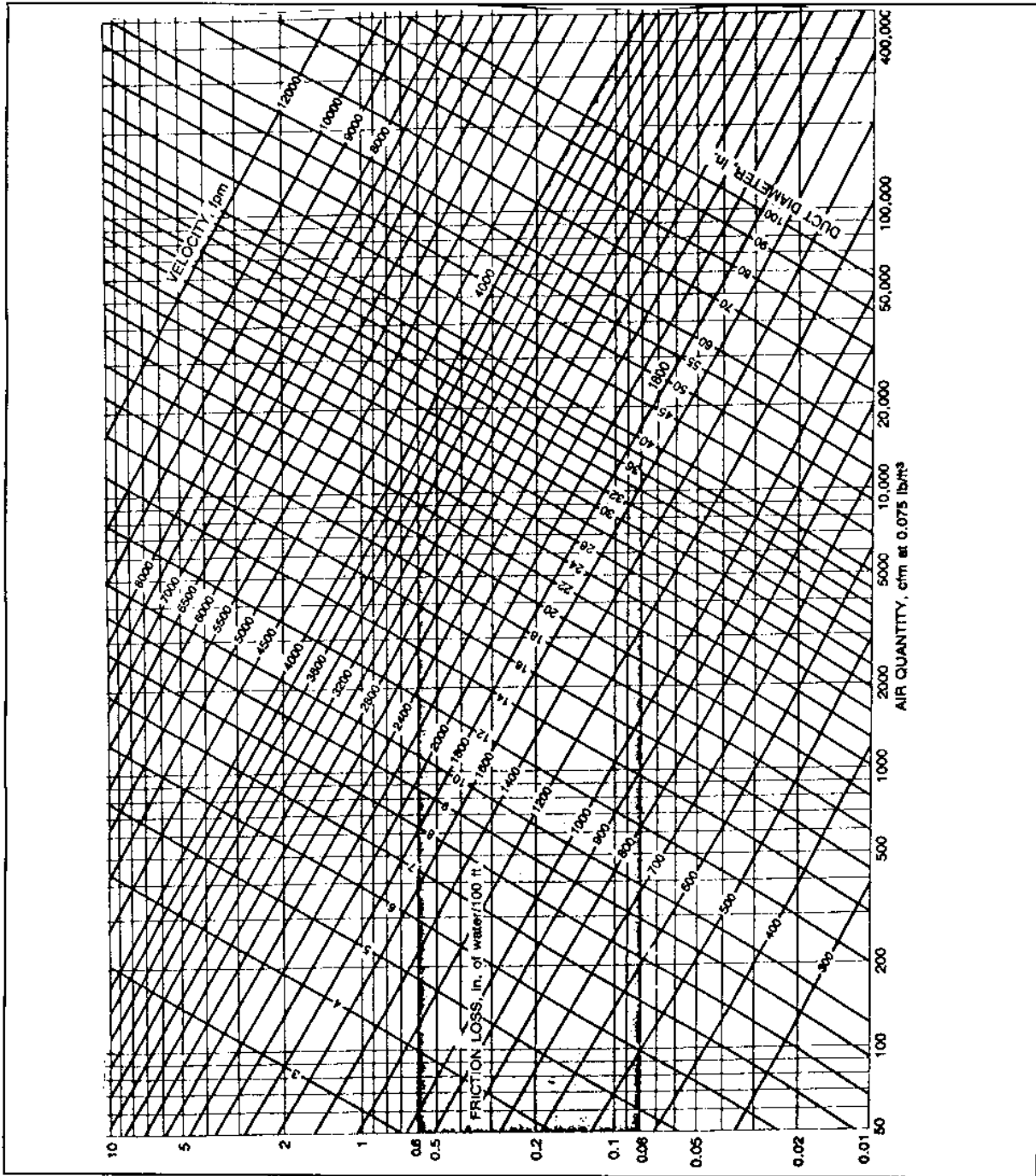

dictate use of mitered elbows, such elbows shall have single thickness turning vanes. Using double thickness turning vanes instead of single thickness vanes increases the pressure loss of elbows by as much as 300 percent. Use the circular equivalents table in ASHRAE Handbook, Fundamentals instead of matching areas when you change aspect ratios. The aspect ratio is the ratio of larger to smaller rectangular duct dimension. Try to use an aspect ratio of 3 to 1 with a maximum aspect ratio of 6 to 1 or less.

6.1.3.3 Access Doors. Show access doors or panels in ductwork for apparatus and devices for maintenance, inspection, and servicing.

6.1.3.4 Flexible Ducts. To save construction expense, flexible duct may be used to connect ceiling outlets. Limit the length of flexible ducts to straight runs of 5 feet. Seek self-balancing by having equal lengths of flexible ducts instead of long and short lengths on the same branch. Do not use flexible ducts for elbows, including connection to diffusers; provide elbows at ceiling diffusers. Do not use flexible ducts in industrial ventilation systems.

6.1.3.5 Rooftop Ductwork. Rooftop ducts exposed to the weather can leak rain water. Exterior insulation tends to have a short life. One way to avoid such problems is to put insulation inside the duct, and then use galvanized steel ductwork with soldered joints and seams. Exterior insulation shall have weatherized coating and wrapping throughout, where it must be used; such as on kitchen exhaust hoods containing grease.

6.1.3.6 Glass Fiber Ductwork. Investigate the bidding climate in your local area before deciding that ductwork made from glass fiber panels will always be less expensive than galvanized steel ductwork. Fiberglass ductwork should be coated inside to avoid bacteria growth. In some parts of the country the sheet metal subcontractor can make or buy metal ducts made on an automatic machine at competitive prices.

6.1.3.7 Balancing Dampers for HVAC. Provide balancing dampers on duct branches and show dampers on drawings. See Figure 3 for damper installation. Use extractors or volume dampers instead of splitter dampers at branch connections. Do not use splitter dampers since they make ductwork more difficult to balance than a job with volume dampers. Provide access in the ceiling and clamping quadrants for dampers or use a type with a remote control that extends through the ceiling. Outdoor air dampers should be located away from the intake louver and after the duct transition to minimize exposure to weather and oversizing of

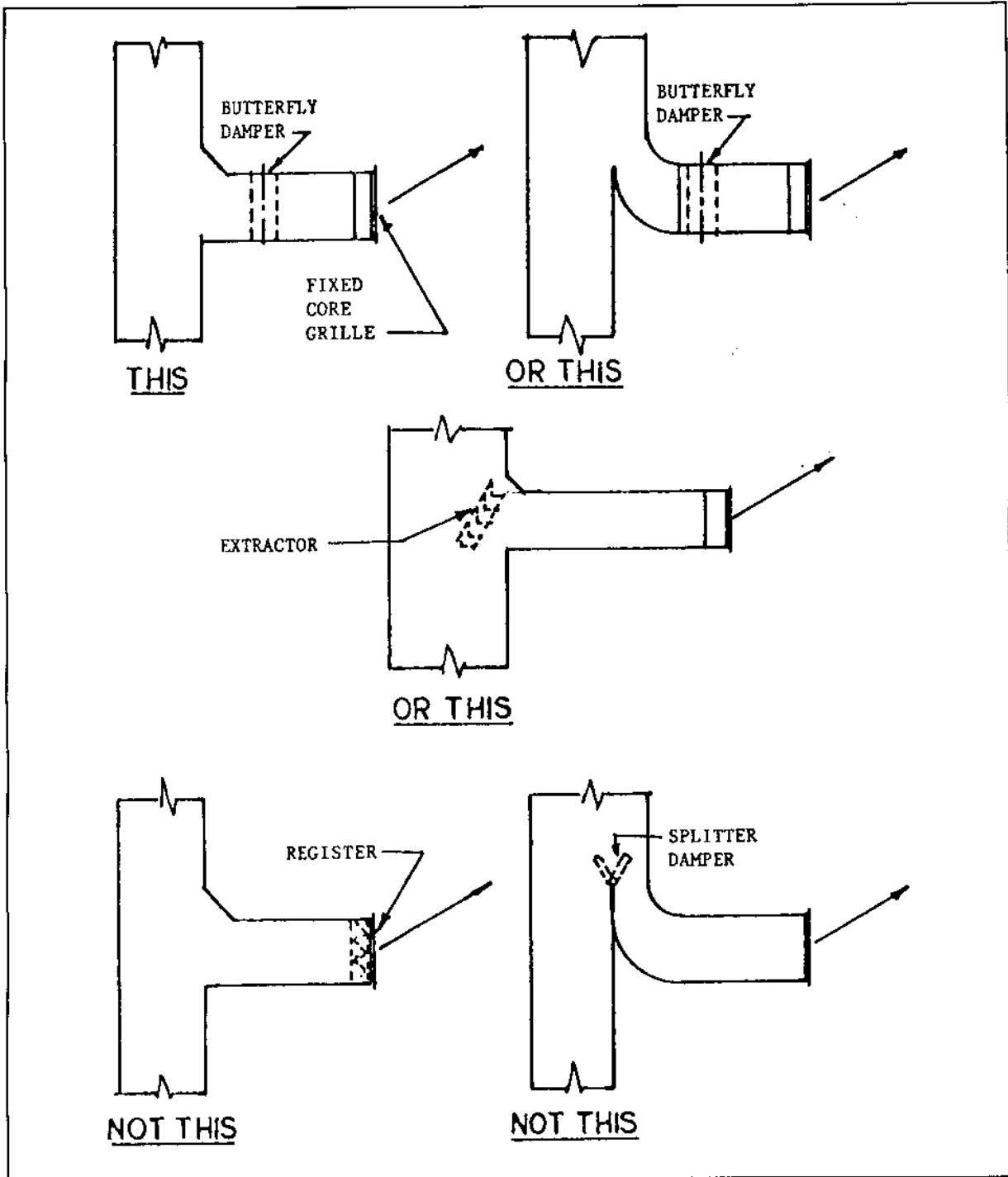

Figure 3  
Damper Installation

dampers. Avoid using balancing dampers for industrial ventilation (IV) systems. Design IV ductwork so that the system will function properly without balancing dampers. Do not use balancing dampers when designing a VAV system. A VAV system with ductwork designed using the static regain method and properly sized VAV terminal units is inherently self-balancing. Refer to Appendix C for additional information.

#### 6.1.3.8 Fire Dampers and Smoke Dampers

a) Fire Dampers. The term "fire damper" usually means a curtain type damper which is released by a fusible link and closes by gravity or a mechanical spring. Fire dampers are mounted in walls of fire rated construction to ensure integrity of the space. Fire dampers should be installed where the passage of flame through a fire rated assembly is prohibited. Refer to par. 4.1.3 for duct pressure classification requirements.

b) Combination Fire and Smoke Dampers. The term "combination fire and smoke damper" usually means a fire damper which is automatically controlled by an external source (such as a fire alarm control panel or energy management system) to stop passage of both fire and smoke. Combination fire and smoke dampers should be installed where passage of fire or smoke is prohibited. Activation of combination fire and smoke dampers can be by several methods including pneumatic damper operators, electric damper operators, and electro-thermal links. Electro-thermal links include explosive squibs which are not restorable and McCabe type links which are restorable. Pneumatically operated dampers are the preferred method of damper activation, and should be configured in the fail-safe mode such that loss of pneumatic pressure will result in dampers closure.

In electronic data processing rooms, combination fire and smoke dampers should be installed in walls with a fire resistance rating of 1 hour or greater. In other type spaces, either fire dampers or combination fire and smoke dampers should be installed in walls with a fire resistance rating of 2 hours or greater. Where a smoke damper is required to stop passage of smoke through a barrier (e.g., hospitals), the installation of a combination fire and smoke damper is required.

c) Mounting Details. Fire dampers and combination fire and smoke dampers must remain in the wall during a fire. Though ductwork may collapse, the damper should remain in the fire rated assembly, therefore, indicate on drawings the details for attaching dampers to the wall. Use UL listed firestopping materials between the damper collar and the wall, floor, or ceiling assembly where penetrated.

6.1.3.9 Fan System Effect Factors. Fans are tested and rated based upon a certain standard ductwork arrangement. If installed ductwork creates adverse flow conditions at the fan inlet or fan outlet, loss of fan performance is defined as a system effect factor. The system effect factor can be caused by obstructions or configurations near the fan inlet and outlet. For example, failure to recognize the affect on performance of swirl at the fan inlet will have an adverse effect on system performance. See Figure 4 for methods to minimize fan system effect factors. Refer to Air Movement and Control Association (AMCA) 201, Fans and Systems for additional information on fans and system effects.

#### 6.1.4 Ductwork Details

6.1.4.1 Branches. See Figure 5 and Figure 6.

6.1.4.2 Elbows. See Figure 7.

6.1.4.3 Offsets and Transitions. See Figure 8.

6.1.5 Testing and Balancing. Ensure duct design includes adequate provision for testing and balancing, including straight sections of duct with ports for velocity measurement. Air straighteners may be required if sufficient lengths of straight duct are not available.

#### 6.2 Fans for HVAC Systems

##### 6.2.1 Fan Selection

6.2.1.1 Major Types of HVAC Fans. See Table 7.

6.2.1.2 Size. In most applications, the fan capacity required is a function of heating and cooling loads, except where there is a minimum prescribed air movement, such as an operating suite in a hospital.

For the total room sensible heat load, calculate the minimum supply air quantity to satisfy the sensible heat load as follows:

$$\text{EQUATION: } \text{CFM} = Q_s / (T_r - T_s) * 1.10 \quad (12)$$

where: CFM = supply air quantity (cubic feet per minute),

$T_r$  = room design temperature (degrees F dry bulb), and

$T_s$  = supply air temperature (degrees F dry bulb)



The quantity of supply air shall also be calculated using the cooling load calculation from equation (5) of par. 5.3.2.

Add the extra dehumidification load of ventilation air (due to lower room humidity) to the grand total heat load.

6.2.1.3 Sound Rating. In large central systems, one should start with the noise limit that may be tolerated in the selected room criteria and then work backwards through the system to the fan. ASHRAE Handbook, HVAC Systems and Applications contains noise guidance, and Army TM 5-805-4 gives noise criteria for various room types. See Table 2-1 of Army TM 5-805-4 for indoor noise criteria.

By isolating the fan on vibration pads, selecting a fan in the efficient range, and utilizing the attenuation of ductwork; the fan and air noise can be controlled. Refer to the fan manufacturer's data sheet for fan noise values.

6.2.1.4 Static Pressure Requirement. To select a fan from the fan manufacturer's fan curves, it becomes necessary to establish the system static pressure requirement as well as the volume of air delivery. With some types of packaged equipment, this rating is called "external static pressure" and static pressure drops required by coils, filters, etc., inside the equipment have already been allowed. With central system fans, however, the static pressure requirement in the entire system must be established to select the total fan static pressure. Verify how individual manufacturers rate their equipment and check their curves and tables for system effects. Select fans so that they will remain stable and not overload at any operating condition.

a) Pressure Drop of Air Handling Systems. Pressure drop calculations of air handling systems shall include:

- (1) Outdoor air intake louvers,
- (2) Dampers,
- (3) Air filters (average between clean and dirty),
- (4) Heating coils,
- (5) Cooling coils (wet, dry, or sprayed condition),
- (6) Moisture eliminators,

Reprinted by permission of American Society of Heating, Refrigerating, & Air-Conditioning Engineers, Inc., Atlanta, GA from ASHRAE Handbook Fundamentals.

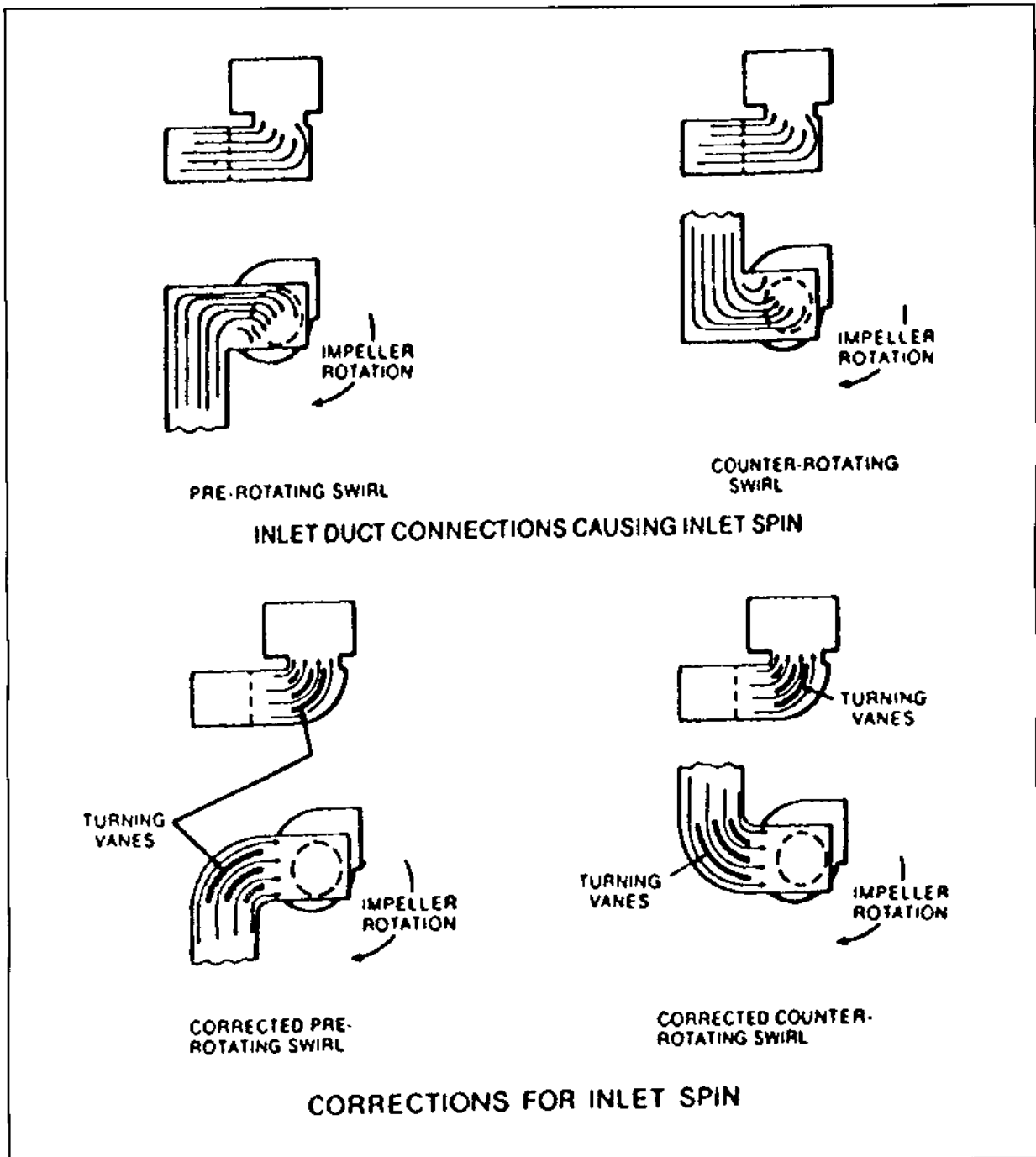

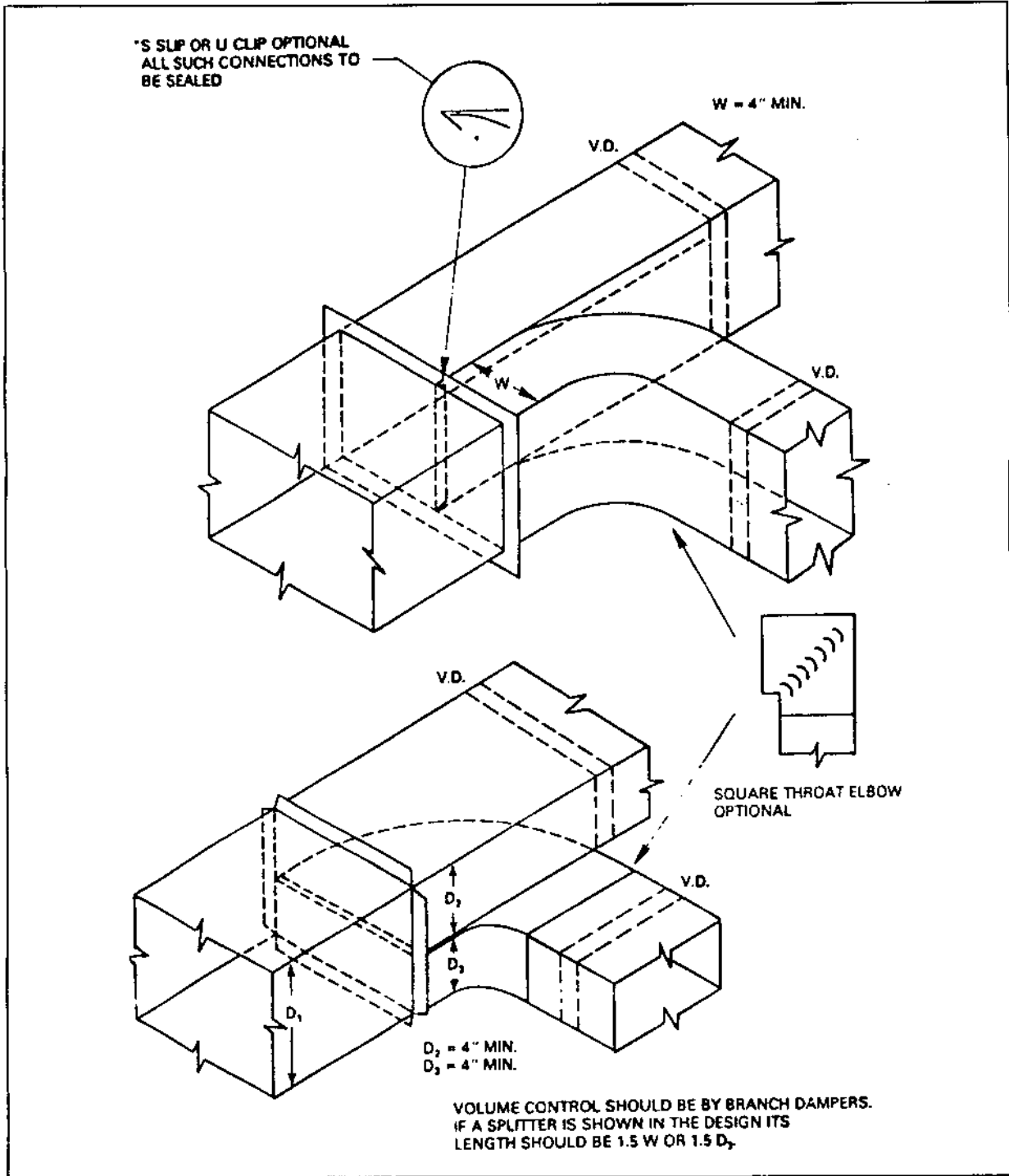

Figure 5  
Duct Branches

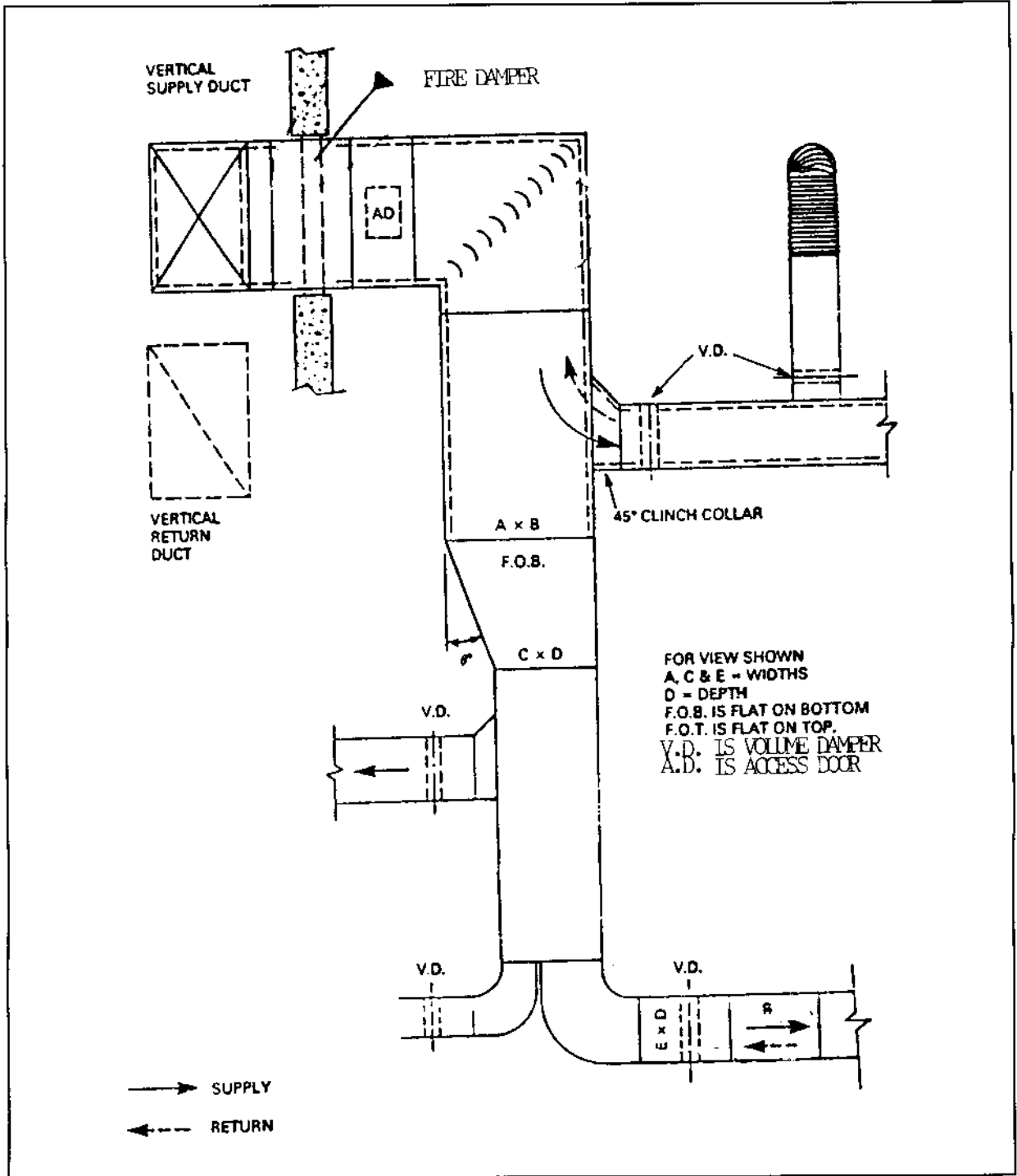

Figure 6  
 Duct Branches

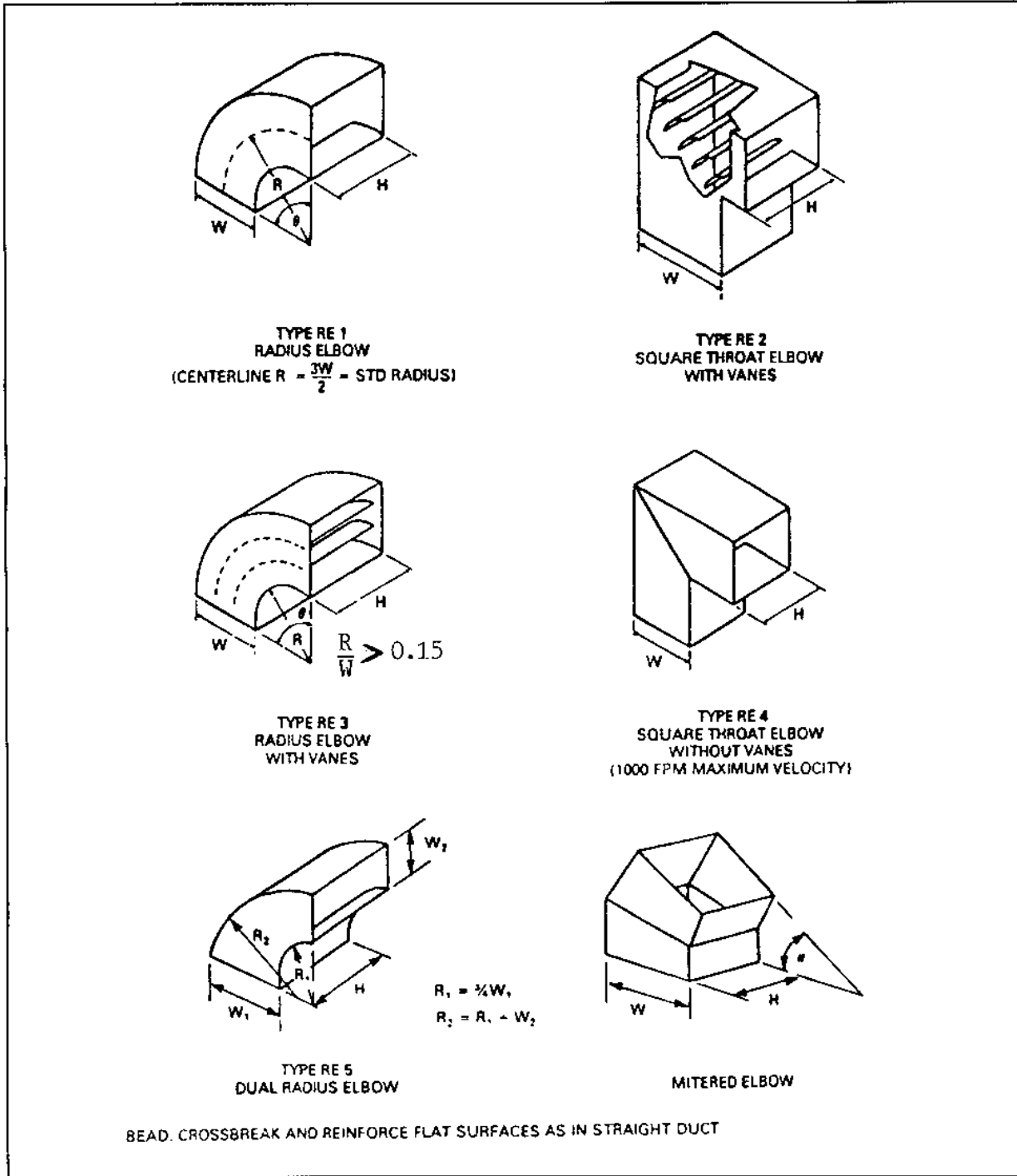
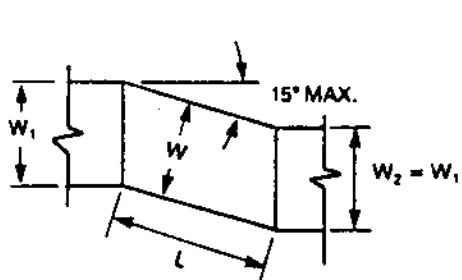
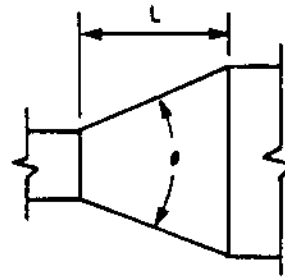

Figure 7  
Duct Elbows

OFFSETS 2 AND 3 AND TRANSITIONS MAY HAVE EQUAL OR UNEQUAL INLET AND OUTLET AREAS. TRANSITIONS MAY CONVERT DUCT PROFILES TO ANY COMBINATION FOR RECTANGULAR, ROUND OR FLAT OVAL SHAPES.



OFFSET TYPE 1  
(ANGLED)



CONCENTRIC TRANSITION  
 $\theta$  MAX. 45° DIVERGING, 60° CONVERGING

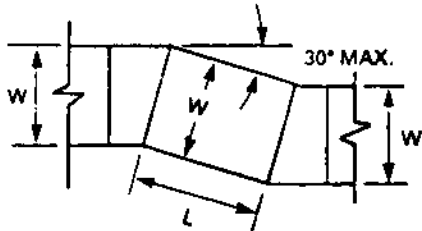

OFFSET TYPE 2  
(MITERED)

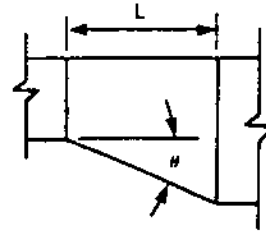

ECCENTRIC TRANSITION  
 $\theta$  MAX. 30°  
(EXCEPT 45° IS PERMITTED  
AT ROUND TO FLAT OVAL)

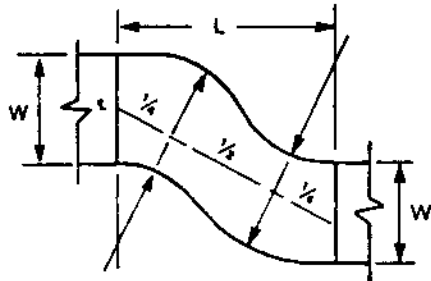

OFFSET TYPE 3  
(RADIUSSED  
OR OGEE)

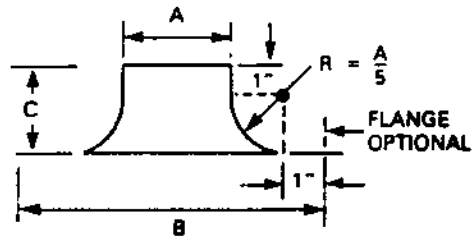

STANDARD BELLMOUTH  
(ON SHORT PATTERN BELL  
 $C = 3"$ ,  $B = A + 4"$ )

Figure 8  
Duct Offsets and Transitions

Table 7  
Major Types of HVAC Fans

<u>Type</u>	<u>HVAC Application</u>
Centrifugal with backward inclined airfoil blades	Large HVAC systems where fan energy efficiency becomes significant
Backward inclined centrifugal	General HVAC
Forward inclined centrifugal	Low pressure HVAC, mainly in furnaces and package equipment
Vane axial	General HVAC where compact size and straight flow is wanted
Propeller	Equipment room ventilation and general ventilation for comfort cooling

(7) Fan entrance (including vortex dampers),

(8) Fan discharge (based on discharge configuration), and

(9) Velocity pressure loss (if fan outlet velocity is lower than duct velocity).

b) Pressure Drop of Duct Systems. Pressure drop calculations of duct systems shall include:

(1) Straight unlined or lined ductwork,

(2) Static pressure regain or loss due to transitions,

(3) Fittings,

(4) Branch takeoffs,

- (5) Obstructions,
- (6) Fire and smoke control dampers,
- (7) Regulating dampers,
- (8) Takeoff neck for air terminal devices,
- (9) Air terminal devices, and
- (10) Sound traps.

6.2.1.5 VAV Fan Selection. When selecting a fan for a VAV system, check fan operating characteristics throughout the range from minimum to maximum flow conditions operating conditions. Fans should not be selected that will become unstable or overloaded for any operating condition. Fan manufacturer shall be AMCA certified. Refer to Appendix C for additional information.

6.3 Economizer Cycle. The economizer cycle provides cooling without refrigeration using outdoor air when outdoor air dry bulb temperature is below a predetermined temperature where the total heat of outdoor air is likely to be lower than that of the return air. Economics of the economizer cycle is particularly attractive for facilities that have interior zones requiring year around cooling or for facilities with internal heat gains higher than heat losses through the envelope of the building. The economizer cycle should only be used with approval of the EFD or EFA. Refer to pars. 8.2, 8.3, 8.4, and 8.5 for the recommended control sequence.

6.4 Terminal Equipment. Conditioned air is delivered to the room through terminal equipment such as grills, registers, ceiling diffusers, etc. To achieve appropriate air diffusion within the room, the terminal equipment should provide:

- a) Mixing of conditioned air with room air, and
- b) Counteraction of natural convection and radiation effects within the room.

The scheme used to deliver conditioned air to the room depends upon room size, geometry, exposures, and use patterns. Outlet types include grills and diffusers mounted in or near the ceiling and floor or low sidewall outlets. Outlet types should be selected to adequately throw supply air across the room; to provide good mixing to prevent drafts; to counter the buoyancy effect of temperature differences; and to avoid obstructions such



as beams and light fixtures that could divert supply air directly on the occupants. Linear slot diffusers are important in VAV systems (refer to Appendix C).

## 6.5 Louvers

a) Louvers are used to admit supply air, discharge exhaust air, or admit return air to the ductwork system. Often these are detailed on architectural drawings and installed under architectural sheet metal because the architectural designer wants to control the esthetics of the building exterior. Consider the following in placement of intake louvers so they are:

(1) Not exposed to blowing dust, driving rain, high winds, auto exhaust fumes (loading docks), embanked snow, or falling leaves.

(2) Away from known odors, airborne contaminants, cooling towers, and industrial exhaust stacks (25 foot minimum).

(3) Away from building entrances where radiated noise from the fan equipment could be annoying.

(4) Away from building exhaust air, building plumbing vents, and odors from kitchen hood exhausts, and laboratory exhausts.

b) In the design of louver blades, a proper compromise must be made between maximum net free area and trapping of windblown rain. See Figure 9 for a typical rain resistant louver.

c) Keep air velocities low through louver intakes to avoid noise and excessive pressure drops. Compute pressure drop based on the percent of free flow area for the louver and the pressure drop through insect and bird screens.

d) For industrial ventilation systems with fume hoods, makeup air should be introduced through a perforated ceiling, ceiling panels, or perforated ducts to distribute the air uniformly throughout the room.

6.6 Filters for HVAC Systems. Use high efficiency filters only if the mission requires clean air since they cost more to install and maintain, take more space, and use more energy. High efficiency filters should be preceded by pre-filters to extend

their life. Use the least efficient filter that will satisfy mission requirements. Some available filter types and their applications include the following:

Filter Type	Applications
Flat throwaway	Window air conditioners, warm air furnaces, packaged unitary equipment, central air handlers (when high efficiency is not required)
Flat permanent	Same as for flat throwaway but require cleaning
Roughing or pre-filters	For removing larger particles ahead of high efficiency filters to extend filter life
High efficiency air (HEPA) filters	Operating rooms, clean rooms, protective shelters
Renewable media (auto-cleaning)	Large outdoor air systems with high dust loads to reduce frequency of filter changes; roughing or pre-filters
Electrostatic	For high efficiency with low pressure drop (precede with pre-filter to reduce cleaning requirements)

Consider also the ambient dust level of the air.

A classic illustration of poor design is a building at a desert station with low air intakes located adjacent to an unlandscaped helipad. Each time a helicopter lands or takes off, huge quantities of dust are drawn into the HVAC filters. When selecting a filter bank for an installation, consider the type of fan and the fan curve. A packaged cabinet fan unit with forward curved blades may not have sufficient static pressure to maintain required airflow with dirty HEPA filters.

6.7 Access for Inspection and Maintenance. Air distribution systems of an HVAC plant require access for inspection and maintenance. During design consider how filters, motors, and fan belts will be replaced and cleaned. Design systems to avoid the following:

a) Using a step ladder in the middle of an office to remove a ceiling tile and rig portable lighting to maintain equipment.

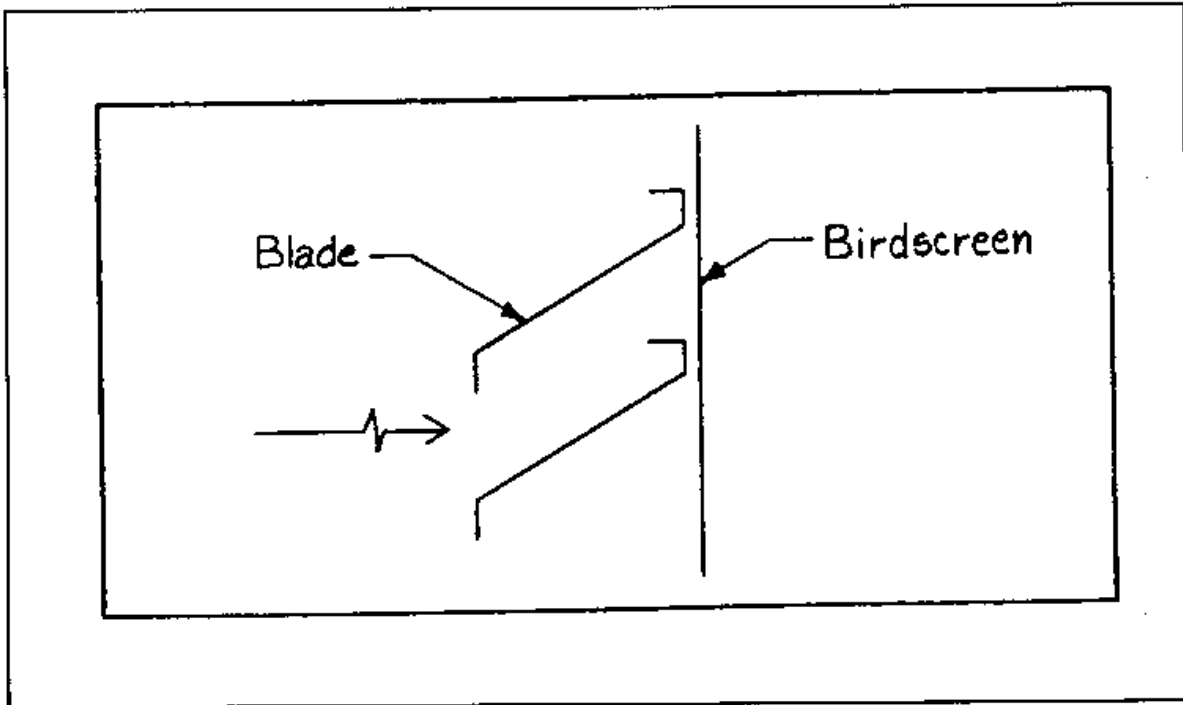

**Figure 9**  
**Hooked Louver Blade**

b) Need to crawl on hands and knees under ductwork carrying filters, tools, etc.

c) Need to climb over a rooftop screening fence to get to roof mounted HVAC equipment.

d) Use of a vertical ladder to open a roof hatch while carrying filters, tools, etc.

e) Need to rig a portable walkway in a ceiling assembly to approach a remote fan coil unit or other equipment.

6.8 VAV System Design. Unless VAV systems are well designed and expertly installed, problems can develop. Refer to Appendix C for design considerations.

6.9 Ductwork Pressure-Velocity Classification. It is essential that ductwork pressure-velocity classification be specified clearly in drawings for each duct system. Note the following:

a) Ductwork pressure-velocity classification may be different for different ductwork systems.

b) Ductwork pressure-velocity classification may be different at different parts of any single duct system.

c) SMACNA HVAC duct construction standards should be used for pressure-velocity classification.

d) SMACNA classifications are based on maximum static pressure as follows:

#### STATIC PRESSURE

Pressure Class	Operating Pressure
1/2" WG	Up to 1/2" WG
1" WG	Over 1/2" WG to 1" WG
2" WG	Over 1" WG to 2" WG
3" WG	Over 2" WG to 3" WG
4" WG	Over 3" WG to 4" WG
6" WG	Over 4" WG to 6" WG
10" WG	Over 6" WG to 10" WG

See Figure 10 for an example of how to delineate duct pressure class designation.

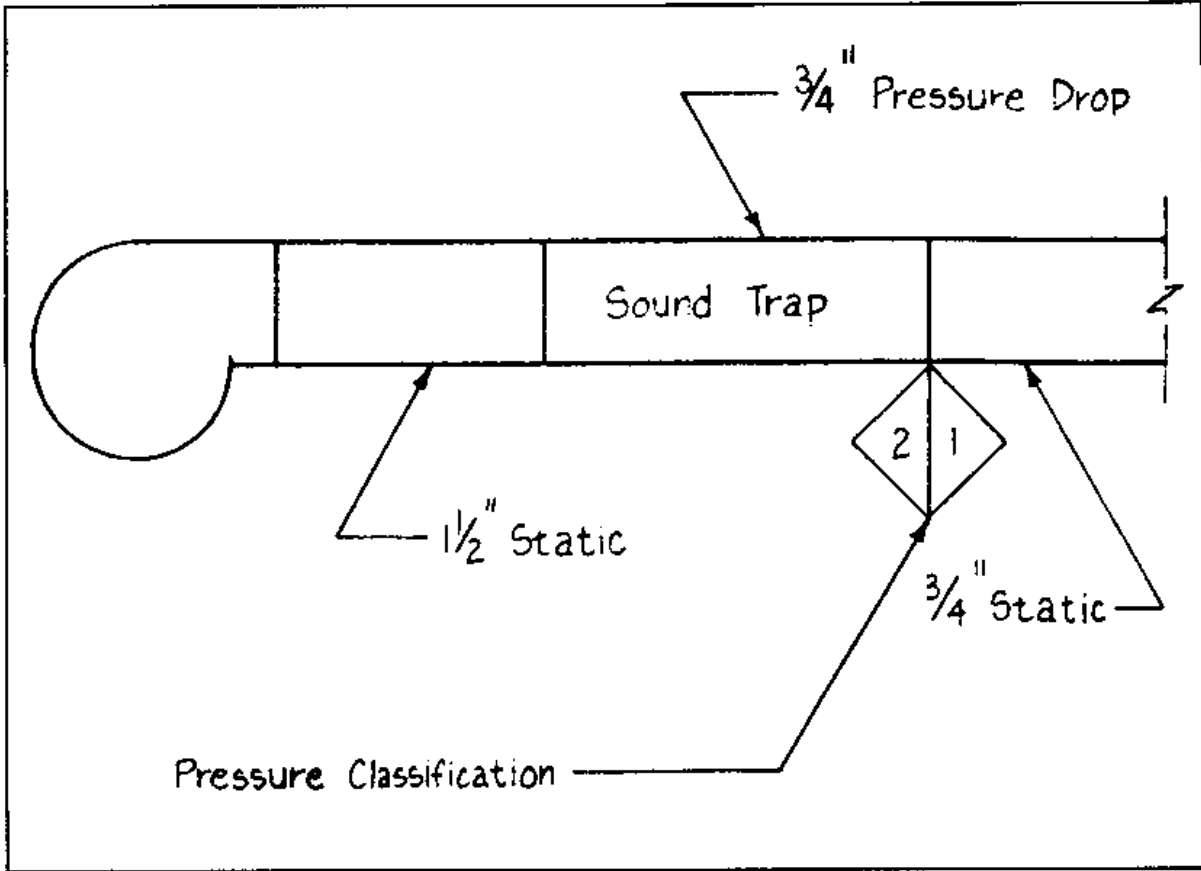

Figure 10  
Duct Pressure Class Designation

## Section 7: PIPING SYSTEMS

7.1 General

7.1.1 Piping Design Factors. Consider the choice between steel and copper piping based on estimated initial cost and life cycle cost of each installation. For a safe pressure of piping and fittings corresponding to working pressure and temperature, refer to ASME B31.1, Power Piping. See Table 8.

Copper piping cannot be corroded by fluorinated hydrocarbon refrigerants, even when this liquid is mixed with moisture. Copper is entirely free of scaling effects. However, steel pipe and fittings are less expensive than copper piping for non-refrigerant systems with larger pipe sizes.

7.1.2 Pipe Friction Loss. For pipe friction loss, see Figures 11 through 13 for water flow and Figures 18 through 21 for steam flow.

7.1.3 System Pressure Loss. Piping system pressure loss calculations shall include the following considerations:

- a) Pipe friction based on 10-year-old pipe;
- b) Pressure loss of valves, fittings, and other associated equipment;
- c) Equipment pressure loss;
- d) Static lift in open systems.

7.1.4 Piping Layouts. Piping layouts shall provide for flow control, subsystem isolation, pipe expansion, elimination of water hammer, air removal, drainage, and cathodic protection. Isolation valves are required in piping systems. To control corrosion, provide cathodic protection as required due to presence of dissimilar metals, stray currents, or soil composition (if using direct burial pipe), as described in MIL-HDBK-1004/10, Electrical Engineering Cathodic Protection.

7.1.5 Expansion. Preferred methods of accommodating thermal expansion are by pipe geometry, e.g., offsets and changes in direction, and pipe loops. Offsets that would cause torsion should be avoided with screwed fittings to prevent the potential for leaking joints. Use expansion joints only when space does not permit proper geometry or installation of pipe loops. For expansion as a function of temperature for steel and copper pipe, and general expansion criteria, see Table 12 of MIL-HDBK-1003/8A,

Exterior Distribution of Utility Steam, High Temperature Water (HTW), Chilled Water, Natural Gas and Compressed Air. For information on piping flexibility design, refer to Crocker, Piping Handbook, Kellogg, Design of Piping Systems, or similar references.

7.1.6 Expansion Loop. On straight pipes, always use expansion loops if space conditions permit.

7.1.7 Packing-Type Expansion and Ball Joints. Provide packing-type expansion and ball joints only if they can be located in accessible areas. These expansion joints shall not be used for refrigerant piping. Packing-type expansion joints can be used, however, for chilled water, hot water, or steam lines under limited conditions. Packing-type joints fail slowly, giving a warning by leakage.

7.1.8 Bellows Expansion Joints. Use bellows-type expansion joints where piping is not easily accessible. Bellows-type joints can fail suddenly without warning and should not be used where personnel would be endangered by a rupture.

7.1.9 Supports and Anchors. Expansion joints should be provided with guides to prevent undue bending movement. Piping between expansion joints should have supports designed to carry the weight of the pipe and fluid together with axial friction loads and the thrust of the expansion joint. Risers and mains should be anchored to prevent excessive strain on branches. Consider whether the building structure will withstand the thrust of piping on the anchor. In light steel or wood frame structures, consider allowing the piping system to float with expansion loops but without anchors.

a) Supports. Provide shields between the insulation and the supports of insulated piping. Provide roller-type guided supports where horizontal pipe is subject to thermal expansion. Provide vertical pipes and main risers with base elbows designed to take the weight of the pipe from the elbow up to the first anchor.

b) Hangers. Provide hangers with vibration isolators, as required. Hangers shall be massive enough to limit the vibration amplitude. Pipe supports shall be wide enough to avoid any swivel action. Use spring hangers when required to accommodate expansion in vertical piping. Provide seismic support in the lateral direction where this is appropriate.

Table 8  
Piping Materials

<u>SERVICE</u>	<u>PIPE</u>	<u>FITTINGS</u>
Suction line (Refrigerant)	Hard copper tubing Type L(1) Steel pipe, standard wall lap welded or seamless for sizes larger than 2 in. IPS	Wrought copper, wrought Brass, or tinned cast brass, 150 lb welded or threaded malleable iron
Liquid line (Refrigerant)	Hard copper tubing Type L(1) Steel pipe: extra strong wall for sizes 1-1/2 in. IPS and smaller. Standard wall for sizes larger than 1-1/2 in. IPS, lap welded or seamless for sizes larger than 2 in. IPS	Wrought copper, wrought or tinned cast brass, 300 lb welded or threaded malleable iron
Hot Gas Line (Refrigerant)	Hard copper tubing Type L(1) Steel pipe, standard wall lap welded or seamless for sizes larger than 2 in. IPS	Wrought copper, wrought brass or tinned cast brass, 300 lb welded or threaded malleable iron
Chilled Water	Black or galvanized steel pipe(2) Hard copper tubing(2)	Welded, galvanized, cast, malleable, or black iron (3) Cast brass, wrought copper, or wrought brass
Condenser or Makeup Water	Galvanized steel pipe(2)	Welded, galvanized cast, malleable iron(3) Cast brass, wrought copper, or wrought brass



Table 8 (Continued)  
Piping Materials

SERVICE	PIPE	FITTINGS
Drain or Condensate Lines	Galvanized steel pipe(2)  Hard copper tubing (2)	Galvanized, drainage, cast, or malleable iron(3) Cast brass, wrought copper, or wrought brass
Steam or Condensate	Black steel pipe(2),(4) Hard copper tubing(2), (4)	Welded or cast iron(3) Cast brass, wrought copper, or wrought brass
Hot Water	Cast steel pipe Hard copper tubing(2)	Welded or cast iron(3) Cast brass, wrought copper, or wrought brass
(1)	Soft copper Type L can be used for sizes 7/8 in. OD and smaller, except for sizes 1/4 in. and 3/8 in. OD (Type K must be used for 1/4 in. and 3/8 in. OD sizes).	
(2)	Normally standard wall steel pipe or Type L hard copper tubing is satisfactory for air conditioning applications, however, the piping material selected shall be checked for design temperature-pressure ratings.	
(3)	Normally 125 lb cast iron and 150 lb malleable iron fittings are satisfactory for air conditioning applications, however, the fitting material selected shall be checked for temperature-pressure ratings.	
(4)	For steam condensate return lines use Schedule 80 black steel or Schedule 80 wrought iron pipe. Where hard copper tubing is used, check for compatibility with condensate.	

7.1.10 Flexible Hose. Flexible connections can be installed between moving components and piping. Consider the dual use of flexible hoses as a union point. Pipe shall be anchored at the end, away from moving components.

## 7.2 Water Systems

7.2.1 General. The following applies to both hot and chilled water systems.

7.2.1.1 Exterior Water Piping Design. For exterior piping design criteria, refer to MIL-HDBK-1003/8A.

7.2.1.2 Water Velocity. Noise, erosion, and pumping costs can be excessive if the water velocity selected is too high. Installation costs become excessive if the selected water velocity is too low. Table 9 gives recommendations:

Table 9  
Water Velocities

<u>Type of Service</u>	<u>Recommended Velocity (fps)</u>
General Service	4 to 7
City Water	3 to 7
Boiler Feed	6 to 15
Pump Suction and Drain Lines	4 to 7

7.2.1.3 Water Treatment. Selection of a water treatment system is based on analysis of makeup water and its anticipated contribution to internal corrosion and scale formation in distribution piping and heat transfer equipment, both of which will affect system efficiency and capacity. Obtain services of a water treatment specialist to perform a water analysis, if not available at the site, and to make specific recommendations on type and quantity of chemicals used. Coordinate the decision on type of chemicals specified with the local environmental program manager to ensure chemicals can be properly handled and disposed of and that pollution control regulations are properly addressed.

7.2.1.4 Pipe Sizing. Refer to ASHRAE Handbook, Fundamentals or Figures 11, 12, and 13 for pipe sizing. Guidance parameters for sizing are as follows:

a) Charts are based on use of 60 degree F water. They are conservative (e.g., overestimate the pressure drop) for 200 degree F water; and are not conservative for chilled water.

b) A mean pressure drop selection might be 2.5 feet/100 feet. Pressure drops of over 4 feet/100 feet can be used for pipes over 2 inches in diameter.

c) Keep the minimum velocity above 2 feet per second, and increase this velocity in down-feed return mains. Lower velocities cause separation of entrained air in the mains.

7.2.1.5 Valve and Fitting Pressure Drops. Add the equivalent valve and fitting piping length to the system when performing hydronic computations.

7.2.1.6 Return Arrangements. The two-pipe reverse return system has two mains, one supplying and one returning water from heating units. The return piping is longer than that of a direct return system and is arranged so that the equivalent lengths of supply and return piping to any heating unit are about equal. Use reverse return piping arrangements on closed systems, if all units or parallel circuits have nearly equal resistance. Do not use reverse return piping on open or once-through systems. Provide a reverse return in an up-feed system, and provide a reverse supply in a down-feed system. Isolation and drain valves are required in piping systems.

7.2.1.7 Air Vents. Water flow, especially through heat transfer equipment, shall be directed to permit natural air venting. Install air vents at system high points.

## 7.2.2 Hot Water Heating Systems

7.2.2.1 Hot Water Piping. Refer to pars. 7.1 and 7.2.1 for piping and pipe sizing.

7.2.2.2 Hot Water Coils. Hot water coils are used in ducts of an HVAC system to heat the air. Their extended surface is provided by fins that are bonded to the coil tube. The most common design is attaching aluminum fins to copper tubing with a mechanical bond. Headers are usually provided between the tubes, with supply water entering the coil low and return high so the coil will be self-venting of any entrained air that enters the coil.

Reprinted by permission of ASHRAE, from ASHRAE Handbook, Fundamentals.

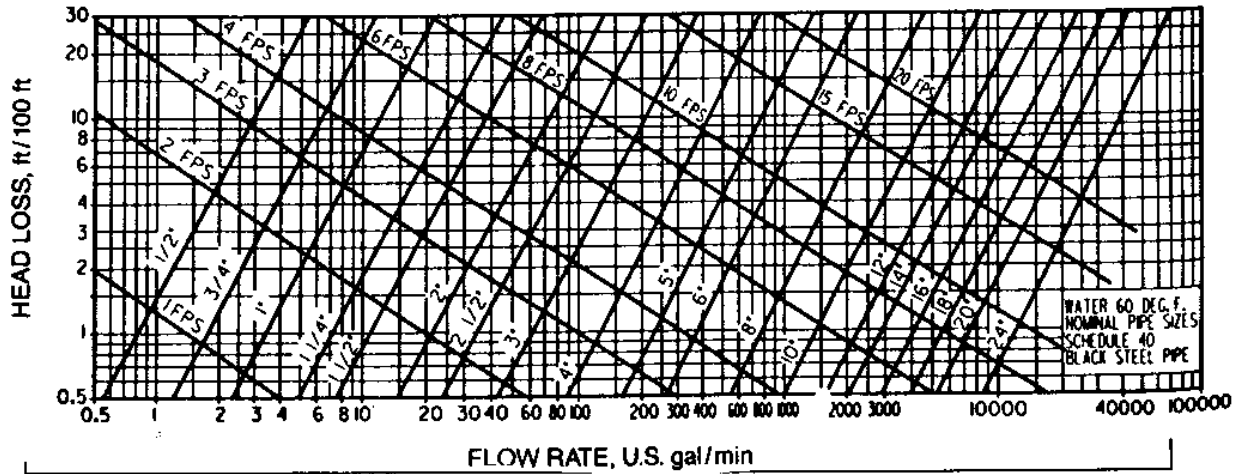

Figure 11  
Friction Loss for Water in Commercial Steel Pipe (Schedule 40)

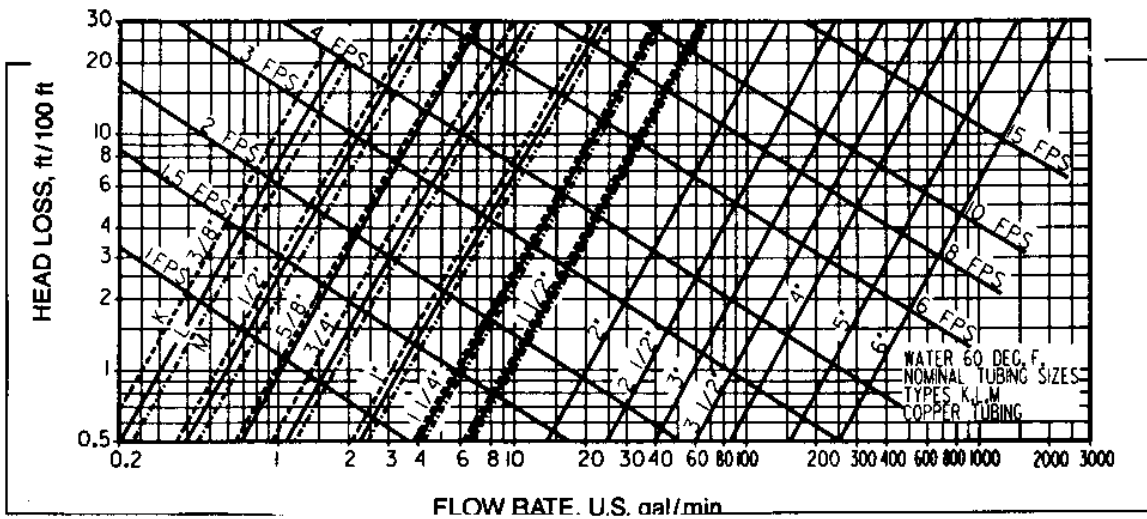

Figure 12  
Friction Loss for Water in Copper Tubing (Types K, L, M)

Reprinted by permission of ASHRAE, from ASHRAE Handbook, Fundamentals.

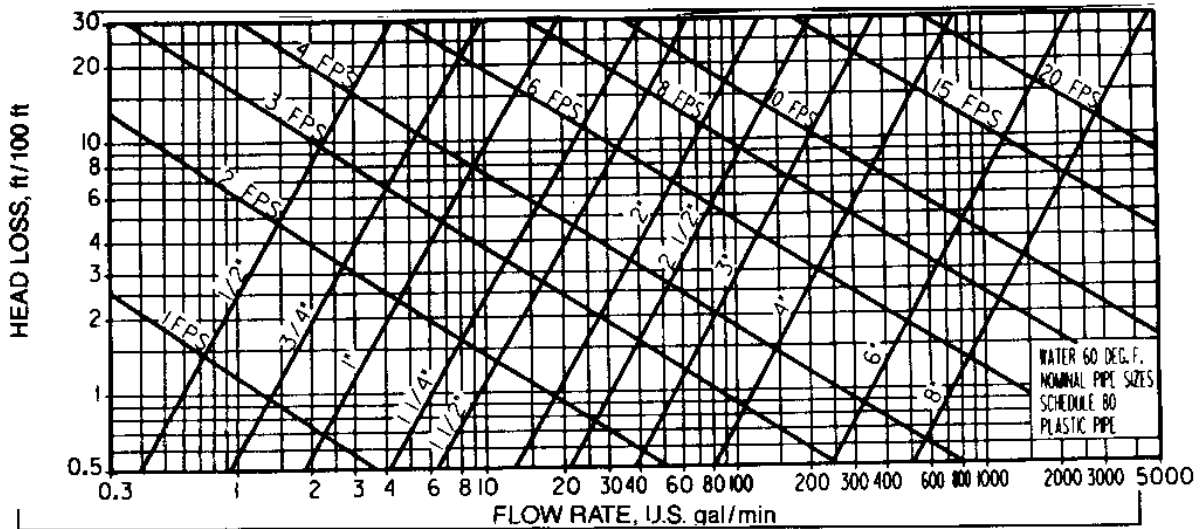

Figure 13  
Friction Loss for Water in Plastic Pipe (Schedule 80)

a) Hot Water Piping to Coil. Water coils will not perform if there is air in the piping. Ensure that the piping from the main, to the coil, and to the return main is appropriately sloped up and vented to eliminate entrained air that can air lock the flow.

b) Hot Water Coil Selection. Consult the manufacturer's catalog data to decide the best selection, number of rows, parallel or counter flow, turbulators or serpentine, and other selection information. Using the appropriate type, make the coil selection:

- (1) Capacity required
- (2) Water temperature in and out
- (3) Air temperature in and out
- (4) Airflow
- (5) Water flow
- (6) Air pressure drop

- (7) Water pressure drop
- (8) Coil face velocity
- (9) Any special requirements

After the coil selection has been made and documented in the design analysis, be sure to provide the above data in the coil schedule on drawings. This will ensure a good bidding climate, with equipment manufacturers knowing what to bid, and what to submit in the shop drawings phase.

#### 7.2.2.3 Expansion Tanks and Air Separator

a) Expansion Tanks General. When water in a hot water heating system is heated, water expands and occupies more volume. System pressure control is needed to:

(1) Limit pressure in all parts of the system to the allowable working pressure.

(2) Maintain minimum pressure in the system to prevent pump cavitation and to prevent boiling of system water.

(3) Minimize addition of makeup water.

b) Expansion Tank With Air Separator. An expansion tank with an air separator performs these system pressure control functions. Since this section does not address medium temperature hot water system (250 to 350 degrees F) or high temperature hot water system (above 350 degrees F); discussion will be limited to the following types of tanks:

(1) Closed expansion tanks with an air cushion. See Figure 14.

(2) Diaphragm (or bladder) type closed expansion tanks. See Figure 15.

Open expansion tanks located at the system high point will also work on low temperature hot water systems, but are not generally used on Navy building projects.

c) Expansion Tanks. Some specifics regarding expansion tanks are as follows:

(1) Expansion tanks are required on chilled water and hot water systems.

(2) Locate the tank on the suction side of the system pump so that system pressure is always positive with respect to atmospheric pressure.

(3) Do not install a shutoff valve between the heat source and the expansion tank.

(4) Refer to ASHRAE Handbook, HVAC Systems and Application or manufacturer's literature for tank sizing.

(5) See Figure 14 for closed expansion tank placement.

(6) See Figure 15 for diaphragm expansion tank placement.

(7) Do not use a gage glass on the expansion tank. A gage glass on a steam boiler is permitted since the wet steam vapor keeps the upper glass packing tight. With an expansion tank, the air will dry out the upper gage glass packing and cause air leaks.

7.2.2.4 Domestic Hot Water Generator. An interface occurs between the heating system and the plumbing system when boiler steam or boiler hot water is used to heat water for plumbing fixtures. Some points to consider in heating domestic hot water are as follows:

a) Domestic water can be heated by the boiler (steam or hot water) or a separate hot water generator, if the heating source is available during the summer. If heated by the space heating boiler, evaluate boiler efficiency for summer operation.

b) If the space heating boiler provides hot water, evaluate if it should be an instantaneous heater, a semi-instantaneous heater, or a storage type hot water generator. The selection will affect the boiler capacity specified. Refer to NAVFAC DM-3.01, Plumbing Systems for domestic hot water system design.

With these decisions made, select the hot water system and equipment. See Figure 16 and Figure 17.

7.2.2.5 Heat Exchangers. Heat exchangers are used for steam to heat water. One medium flows through the shell, and the other medium flows through the tubes in the tube bundle. Include the following in the equipment schedule:

a) Water flow

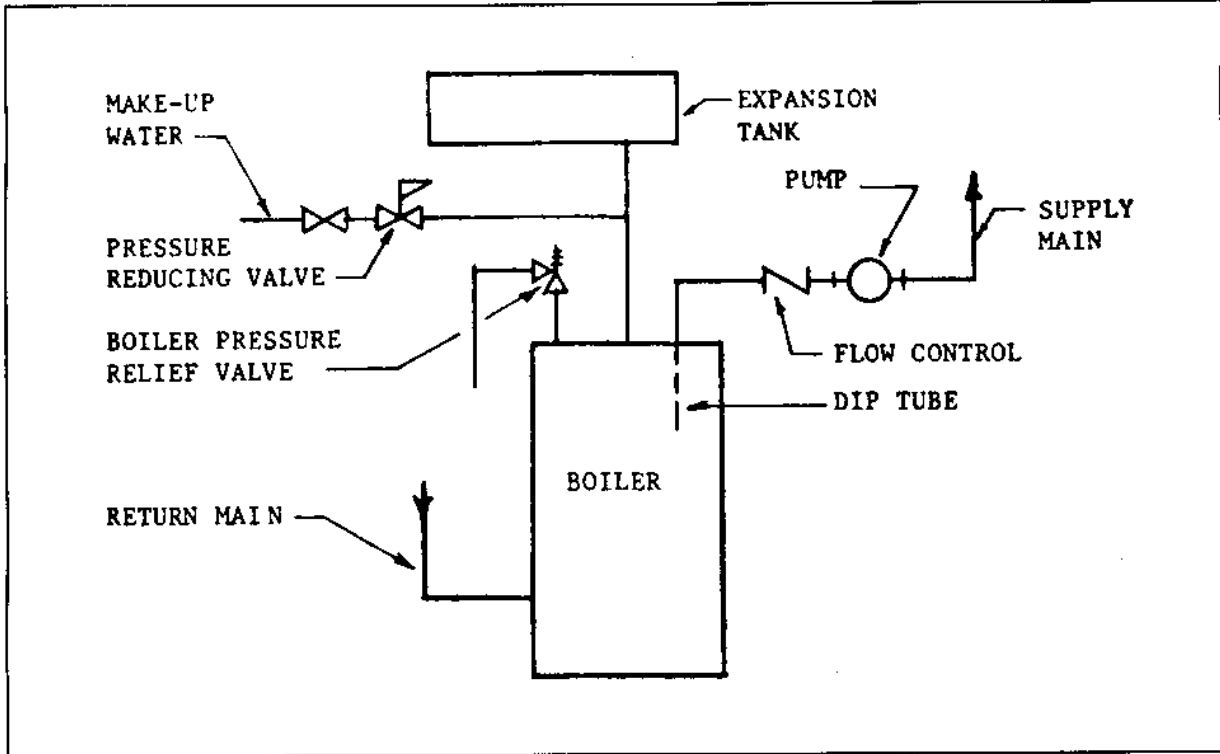

Figure 14  
Closed Expansion Tank



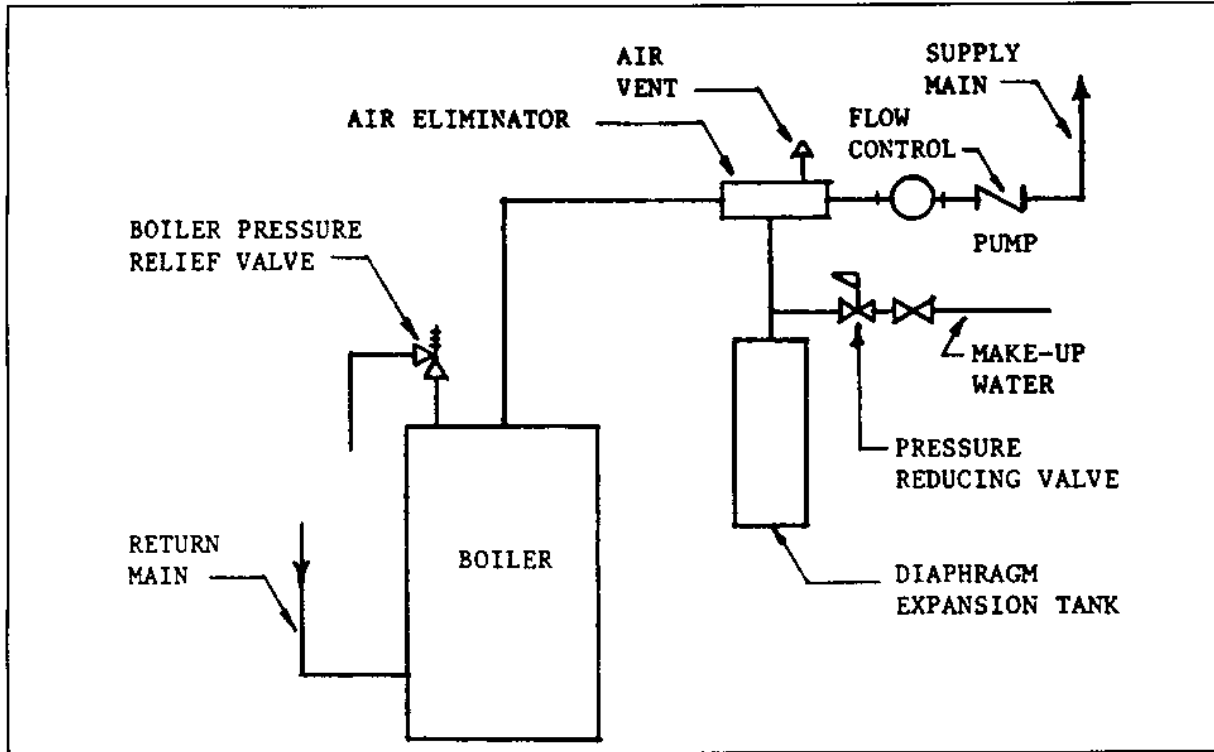

Figure 15  
Diaphragm Expansion Tank

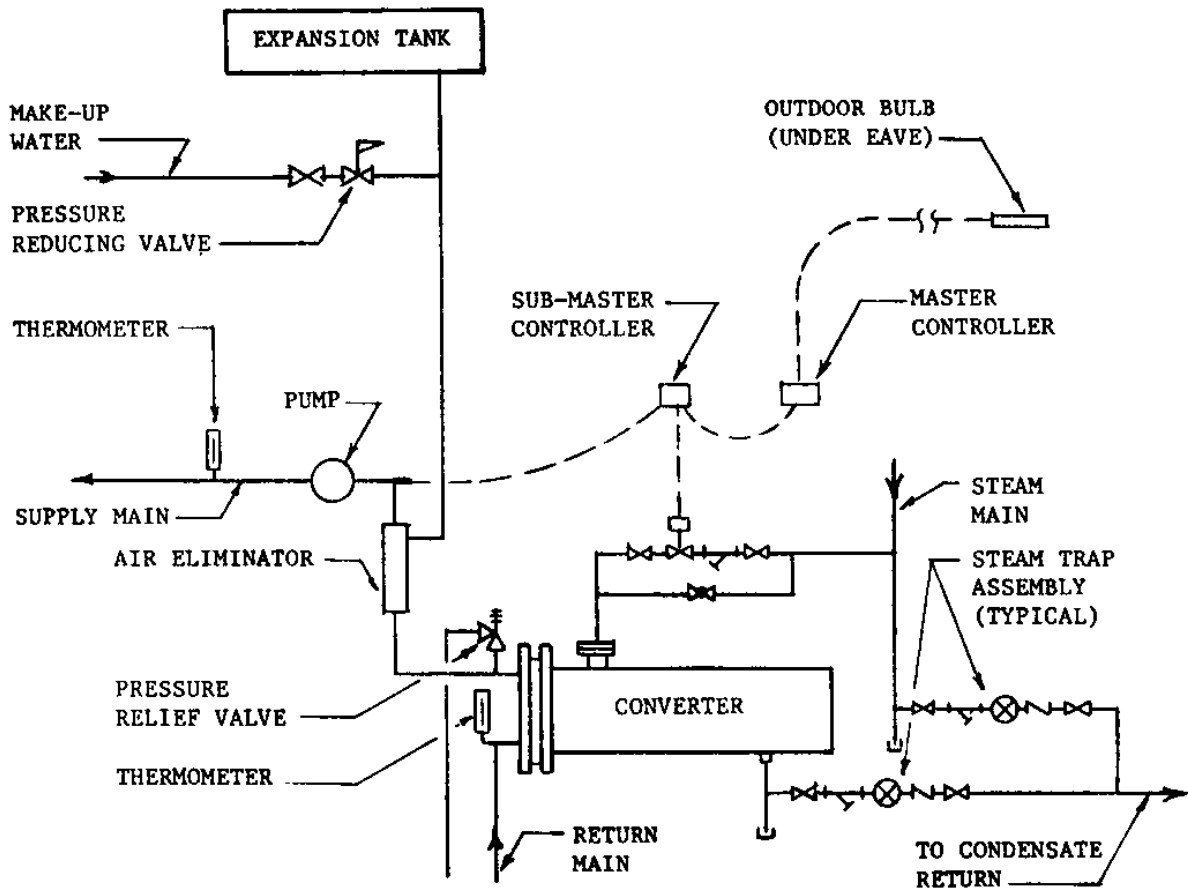

Figure 16  
Connections to Converter for Hot Water Heating System

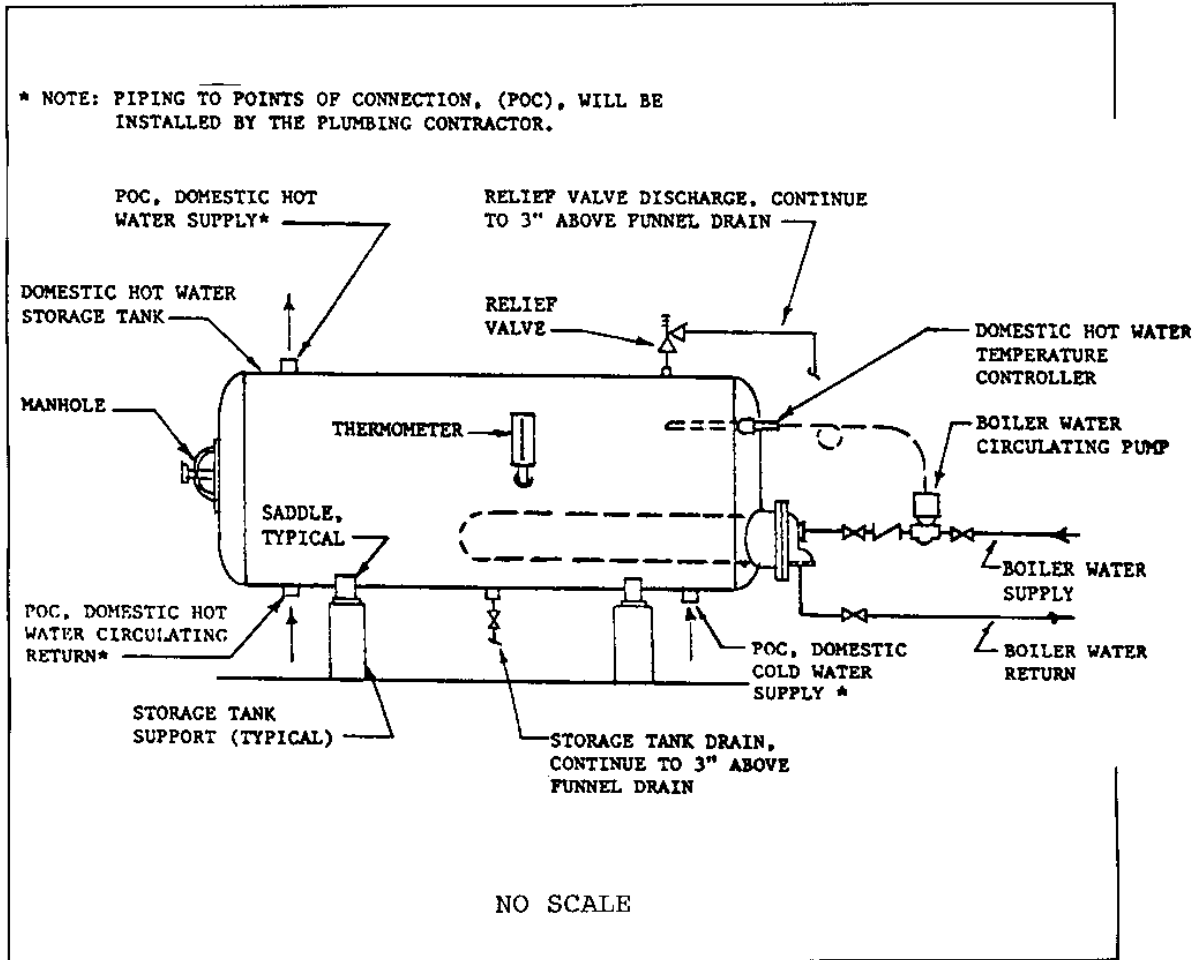

Figure 17  
 Domestic Hot Water Generator and Heating  
 Hot Water Boiler Piping Connection

- b) Inlet water temperature
- c) Leaving water temperature
- d) Water pressure head loss
- e) Inlet steam pressure

- f) Steam flow
- g) Trap size and rating
- h) Shell pressure rating
- i) Tube bundle pressure rating
- j) Control Valve Cv
- k) Temperature control scheme (e.g., resetting the water temperature from the outdoor temperature)

Converters shall be ASME rated and stamped. Detail the supports for the converter and the expansion tank. See Figures 16 and 17.

7.2.2.6 Pumps. In hydronic systems that are larger than residential size, a two pipe system with a circulating pump is required to make the heating system responsive to load changes. Note the following:

- a) Provide a pressure gage on each side of the pump, or a differential gage connected between pump suction and discharge to facilitate system balancing.
- b) Provide flow gages in the branches of multizone systems to facilitate balancing.
- c) Provide gate valves and unions or flanges on inlet and outlet piping to equipment to expedite future removal and repairs.
- d) Provide strainers on the suction side of the pump.
- e) Do not overestimate the pumping head on the pump. A conservative overestimation of the head can result in the pump delivering more than the required gpm and thereby requiring more horsepower than estimated. There are three solutions to this:
  - (1) Specify a pump that is non-overloading,
  - (2) Show a throttling valve in the pump discharge to increase the head if needed, and
  - (3) Remove the impeller and machine it to reduce capacity.

f) Low temperature hot water heating systems are often designed for a 20 degree F temperature drop. This makes it easy to size the pump--divide the Btu's by 10,000 to obtain the pump gpm.

g) Pumping systems that are open, such as cooling towers, or systems with hot liquids, such as a deaerator feed pump, require special attention to ensure proper NPSH. Keep the pump low enough and close enough to maintain proper NPSH.

h) Calculate pipe and fitting friction drop, the head loss through the coils, control valves, heat exchanger, etc. To this add any static head, if the system is not a closed system. Also add nozzle loss for spray equipment, such as evaporative condensers, cooling towers with nozzles, or air washers.

I) Arrange pumps in parallel, i.e., one pump for each boiler, chiller, cooling tower, etc.

### 7.2.3 Chilled Water

7.2.3.1 Pipe Size. Refer to pars. 7.1 and 7.2.1. For dual temperature systems, note that the required temperature difference and the required flow may be different for heating and for cooling operation.

7.2.3.2 Coils. Refer to par. 7.2.2.2. Note the following:

a) Multiple rows may be needed for humidity control. With cooling coils it is important to specify the entering and leaving wet bulb temperature and add the latent load of dehumidification.

b) Dehumidifying coils will need drip pans and drains.

7.2.3.3 Expansion Tanks. Refer to par. 7.2.2.3. Expansion tanks are required to provide for change in water volume due to changes in temperature.

7.2.3.4 Pumps. Refer to par. 7.2.2.6. It is common with large chilled water systems to check the economics of pumping systems. Is it lower cost to pump more or less flow on the chilled water and cooling water circuits? Should colder chilled water, smaller or larger pipes, a bigger chiller, warmer condenser water, or smaller cooling towers be used? Evaluate the life cycle economics on several alternatives to select the most cost effective solution.

### 7.3 Steam

7.3.1 General. Low pressure steam in HVAC systems is defined as 15 psi or less. High pressure steam in HVAC systems is defined as being 16 psi to 150 psi. There is a trend away from using direct steam in HVAC systems. If one gets heat from district steam or a steam boiler, the designer will often convert the steam to hot water through a heat exchanger to supply the HVAC system. The reasons for using hot water HVAC systems include the following:

- a) Eliminates maintenance of many steam traps.
- b) More flexible when planning temperature controls.

### 7.3.2 Low Pressure Steam Systems

7.3.2.1 Pipe Sizing. Pipe sizing for low pressure steam and return mains is found in ASHRAE Handbook, Fundamentals. See Tables 10 through 13. Note the following:

- a) Slope steam mains in the direction of the flow ( $\frac{1}{2}$  inch in 10 feet is recommended).
- b) Slope return mains similarly.
- c) Avoid lifts on low pressure returns, or make them small.
- d) Pumped returns are preferred to gravity returns.
- e) Provide a step-up and drip at the base of steam risers.
- f) Drip the low point if steam flow is against the condensate flow and upsize piping to the next larger size to allow condensate to run back in the bottom of the steam pipe.

### 7.3.3 High Pressure Steam Systems

7.3.3.1 Pipe Sizing. Refer to par. 7.3.2.1. Note the following:

- a) See Figures 18 through 21 for steam pipe sizing.

Table 10  
 Flow Rate in lb/h of Steam Schedule 40 Pipe<sup>a</sup>  
 at Initial Saturation Pressure of 3.5 and 12 psig<sup>b,c</sup>

Nominal Pipe Size, in.	Pressure Drop—psf/100 ft in Length													
	1/16 psi (1 oz)		1/8 psi (2 oz)		1/4 psi (4 oz)		1/2 psi (8 oz)		3/4 psi (12 oz)		1 psi		2 psi	
	Sat. press., psig	Sat. press., psig	Sat. press., psig	Sat. press., psig	Sat. press., psig	Sat. press., psig	Sat. press., psig	Sat. press., psig	Sat. press., psig	Sat. press., psig	Sat. press., psig	Sat. press., psig	Sat. press., psig	Sat. press., psig
	3.5	12	3.5	12	3.5	12	3.5	12	3.5	12	3.5	12	3.5	12
3/4	9	11	14	16	20	24	29	35	36	43	42	50	60	73
1	17	21	26	31	37	46	54	66	68	82	81	95	114	137
1 1/4	36	45	53	66	78	96	111	138	140	170	162	200	232	280
1 1/2	56	70	84	100	120	147	174	210	218	260	246	304	360	430
2	108	134	162	194	234	285	336	410	420	510	480	590	710	850
2 1/2	174	215	258	310	378	460	540	660	680	820	780	950	1150	1370
3	318	380	465	550	660	810	960	1160	1190	1430	1380	1670	1950	2400
3 1/2	462	550	670	800	990	1218	1410	1700	1740	2100	2000	2420	2950	3450
4	640	800	950	1160	1410	1690	1980	2400	2450	3000	2880	3460	4200	4900
5	1200	1430	1680	2100	2440	3000	3570	4250	4380	5250	5100	6100	7500	8600
6	1920	2300	2820	3350	3960	4850	5700	7000	8600	8400	10 000	11 900	14 200	16 500
8	3900	4800	5570	7000	8100	10 000	11 400	14 300	14 500	17 700	16 500	20 500	24 000	29 500
10	7200	8800	10 200	12 600	15 000	18 200	21 000	26 000	26 200	32 000	30 000	37 000	42 700	52 000
12	11 400	13 700	16 500	19 500	23 400	28 400	33 000	40 000	41 000	49 500	48 000	57 500	67 800	81 000

<sup>a</sup>Based on Moody Friction Factor, where the flow of condensate does not inhibit the flow of steam.  
<sup>b</sup>The flow rates at 3.5 psig cover saturated pressure from 1 to 6 psig, and the rates at 12 psig cover saturated pressure from 8 to 16 psig with an error not exceeding 8 percent.  
<sup>c</sup>The steam velocities corresponding to the flow rates given in this table can be found from the basic chart and velocity multiplier chart, Figure 11.

Reprinted by permission of ASHRAE, from ASHRAE Handbook, Fundamentals.

Table 11  
Return Main and Riser Capacities for Low-Pressure System, lb/h

Pipe Size, in.	1/32 psi or 1/2 oz Drop per 100 ft			1/24 psi or 2/3 oz Drop per 100 ft			1/16 psi or 1 oz Drop per 100 ft			1/8 psi or 2 oz Drop per 100 ft			1/4 psi or 4 oz Drop per 100 ft			1/2 psi or 8 oz Drop per 100 ft			
	Wet	Dry	Vac.	Wet	Dry	Vac.	Wet	Dry	Vac.	Wet	Dry	Vac.	Wet	Dry	Vac.	Wet	Dry	Vac.	
	G	H	I	J	K	L	M	N	O	P	Q	R	S	T	U	V	W	X	Y
Return Main	3/4	—	—	—	—	—	42	—	—	100	—	—	142	—	—	200	—	—	283
	1	125	62	—	145	71	143	175	80	175	250	103	249	350	115	350	—	—	494
	1 1/4	213	130	—	248	149	244	300	168	300	425	217	426	600	241	600	—	—	848
	1 1/2	338	206	—	393	236	388	475	265	475	675	340	674	950	378	950	—	—	1340
	2	700	470	—	810	535	815	1000	575	1000	1400	740	1420	2000	825	2000	—	—	2830
	2 1/2	1180	760	—	1580	868	1360	1680	950	1680	2350	1230	2380	3350	1360	3350	—	—	4730
	3	1880	1460	—	2130	1560	2180	2680	1750	2680	3750	2250	3800	5350	2500	5350	—	—	7560
	3 1/2	2750	1970	—	3300	2200	3250	4000	2500	4000	5500	3230	5680	8000	3580	8000	—	—	11,300
	4	3880	2930	—	4580	3350	4500	5500	3750	5500	7750	4830	7810	11,000	5380	11,000	—	—	15,500
	5	—	—	—	—	—	7880	—	—	9680	—	—	13,700	—	—	19,400	—	—	27,300
	6	—	—	—	—	—	12600	—	—	15,500	—	—	22,000	—	—	31,000	—	—	43,800
Riser	3/4	—	48	—	—	48	143	—	48	175	—	48	249	—	48	350	—	—	494
	1	—	113	—	—	113	244	—	113	300	—	113	426	—	113	600	—	—	848
	1 1/4	—	248	—	—	248	388	—	248	475	—	248	674	—	248	950	—	—	1340
	1 1/2	—	375	—	—	375	815	—	375	1,000	—	375	1,420	—	375	2,000	—	—	2830
	2	—	750	—	—	750	1360	—	750	1680	—	750	2380	—	750	3350	—	—	4730
	2 1/2	—	—	—	—	—	2180	—	—	2680	—	—	3800	—	—	5350	—	—	7560
	3	—	—	—	—	—	3250	—	—	4000	—	—	5680	—	—	8000	—	—	11,300
	3 1/2	—	—	—	—	—	4480	—	—	5500	—	—	7810	—	—	11,000	—	—	15,500
	4	—	—	—	—	—	7880	—	—	9680	—	—	13,700	—	—	19,400	—	—	27,300
	5	—	—	—	—	—	12,600	—	—	15,500	—	—	22,000	—	—	31,000	—	—	43,800

Table 12  
Comparative Capacity of Steam Lines  
at Various Pitches for Steam and Condensate  
Flowing in Opposite Directions (From Laschober et al. 1966)

Pipe Size Inches	1/4 in.		1/2 in.		1 in.		1 1/2 in.		2 in.		3 in.		4 in.		5 in.	
	Capac- ity	Max. Vel.	Capac- ity	Max. Vel.	Capac- ity	Max. Vel.	Capac- ity	Max. Vel.	Capac- ity	Max. Vel.	Capac- ity	Max. Vel.	Capac- ity	Max. Vel.	Capac- ity	Max. Vel.
3/4	3.2	8	4.1	11	5.7	13	6.4	14	7.1	16	8.3	17	9.9	22	10.5	22
1	6.8	9	9.0	12	11.7	15	12.8	17	14.8	19	17.3	22	19.2	24	20.5	25
1 1/4	11.8	11	15.9	14	19.9	17	24.6	20	27.0	22	31.3	25	33.4	26	38.1	31
1 1/2	19.8	12	25.9	16	33.0	19	37.4	22	42.0	24	46.8	26	50.8	28	59.2	33
2	42.9	15	54.0	18	68.8	24	83.3	27	92.9	30	99.6	32	102.4	32	115.0	33

Velocity in ft/s. Capacity in lb/h

Reprinted by permission of ASHRAE, from ASHRAE Handbook, Fundamentals.



**Table 13**  
**Steam Pipe Capacities for Low-Pressure Systems**  
 (For one-pipe or two-pipe systems in which condensate flows against the steam flow)

Nominal Pipe Size, in.	Capacity, lb/h				
	Two-Pipe System		One-Pipe Systems		
	Condensate flowing against steam		Supply risers up-feed	Radiator valves and vertical connections	Radiator and riser runouts
	Vertical	Horizontal			
A	B <sup>a</sup>	C <sup>c</sup>	D <sup>b</sup>	E	F <sup>c</sup>
¾	8	7	6	—	7
1	14	14	11	7	7
1¼	31	27	20	16	16
1½	48	42	38	23	16
2	97	93	72	42	23
2½	159	132	116	—	42
3	282	200	200	—	65
3½	387	288	286	—	119
4	511	425	380	—	186
5	1050	788	—	—	278
6	1800	1400	—	—	545
8	3750	3000	—	—	—
10	7000	5700	—	—	—
12	11500	9500	—	—	—
16	22000	19000	—	—	—

Note: Steam at an average pressure of 1 psig is used as a basis of calculating capacities.

<sup>a</sup>Do not use Column B for pressure drops of less than 1/16 psi per 100 ft of equivalent run. Use Figure 10 or Table 13 instead.

<sup>b</sup>Do not use Column D for pressure drops of less than 1/24 psi per 100 ft of equivalent run, except on sizes 3 in. and over. Use Figure 10 or Table 13 instead.

<sup>c</sup>Pitch of horizontal runouts to risers and radiators should be not less than ½ in./ft. Where this pitch cannot be obtained, runouts over 8 ft in length should be one pipe size larger than called for in this table.

Reprinted by permission of ASHRAE, from ASHRAE Handbook, Fundamentals.

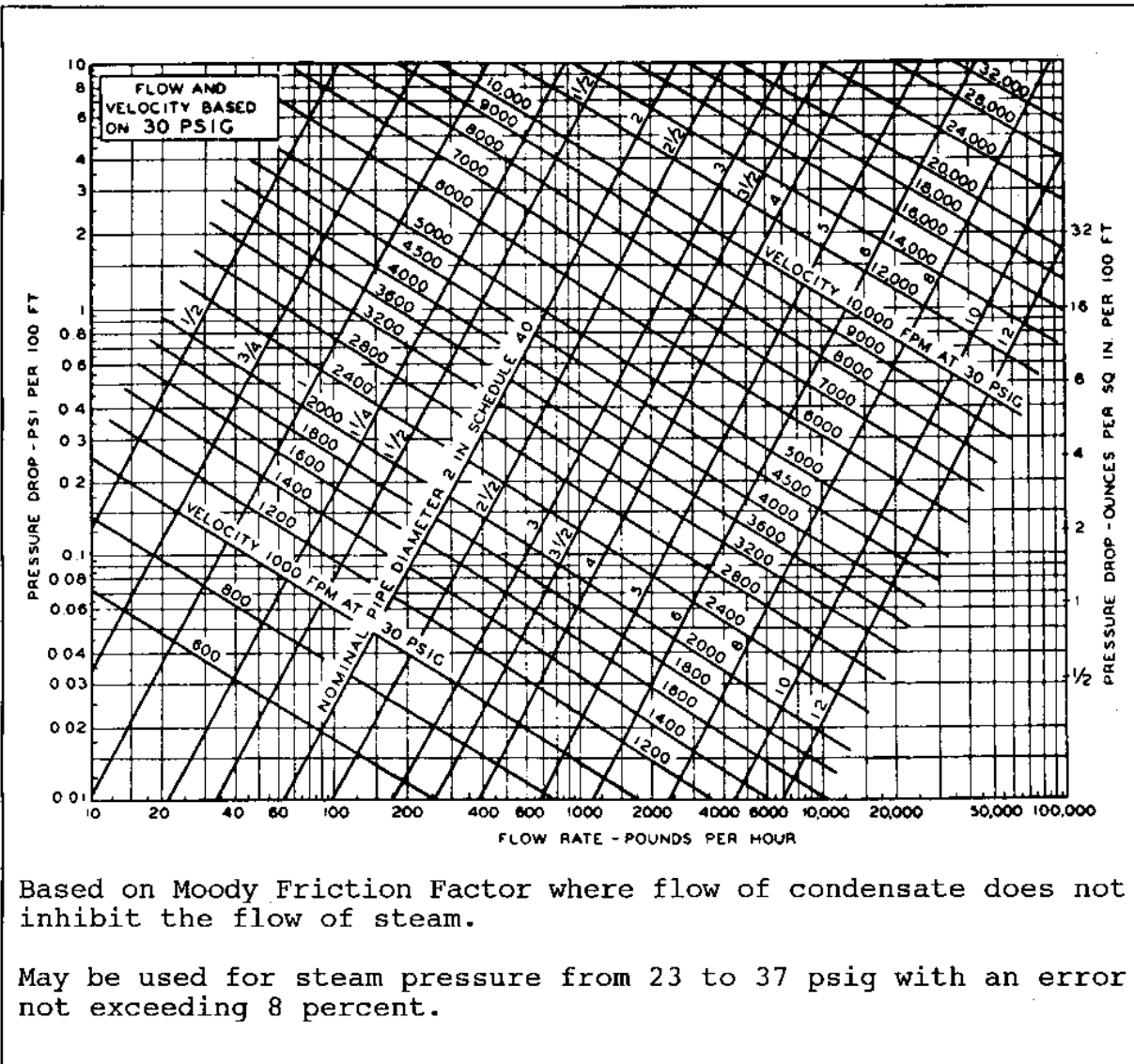

Figure 18  
 Chart for Flow Rate and Velocity of Steam in Schedule 40  
 Pipe Based on Saturation Pressure of 30 psig

Reprinted by permission of ASHRAE, from ASHRAE Handbook, Fundamentals.

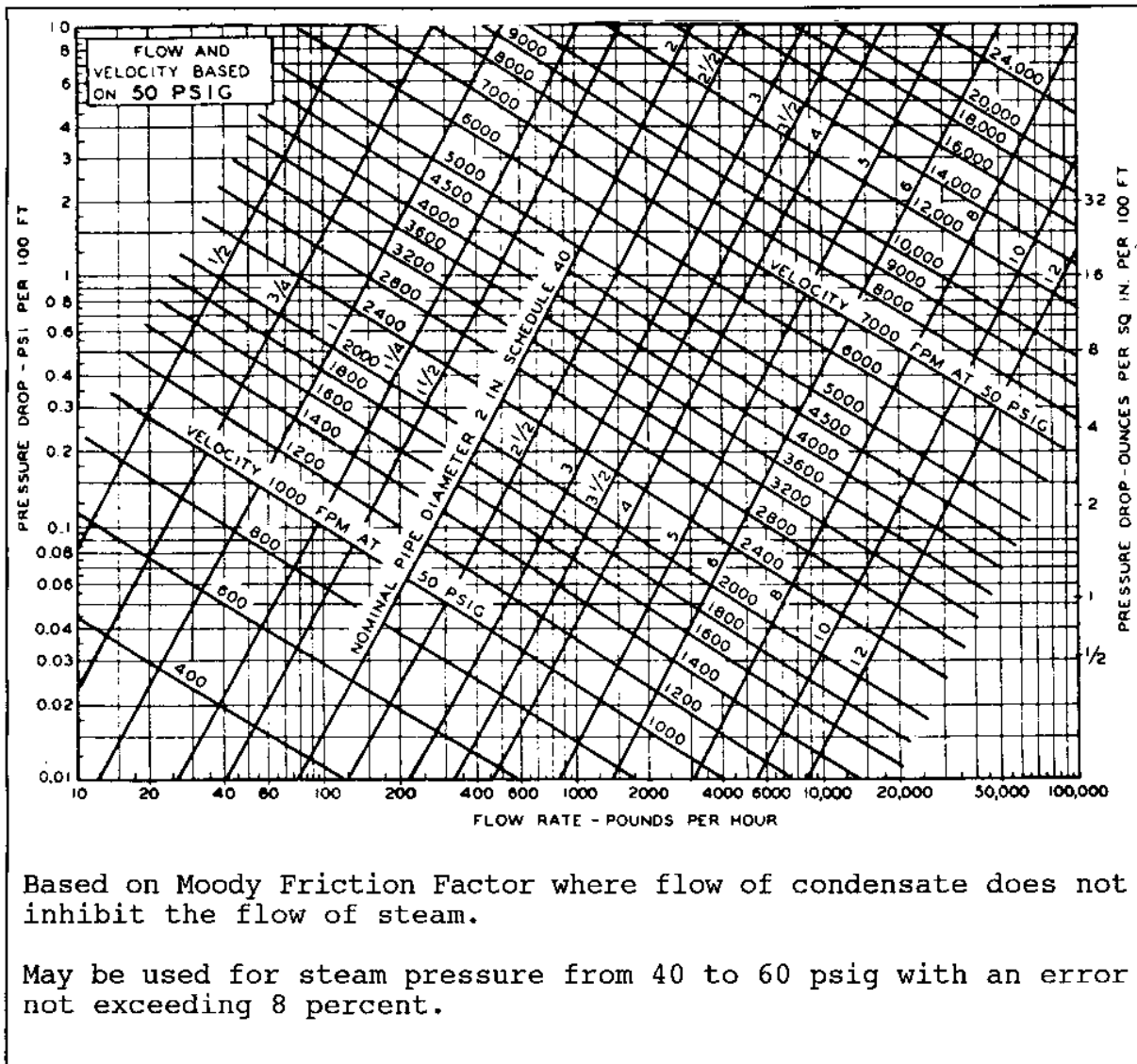

Figure 19  
 Chart for Flow Rate and Velocity of Steam in Schedule 40  
 Pipe Based on Saturation Pressure of 50 psig

Reprinted by permission of ASHRAE, from ASHRAE Handbook, Fundamentals.

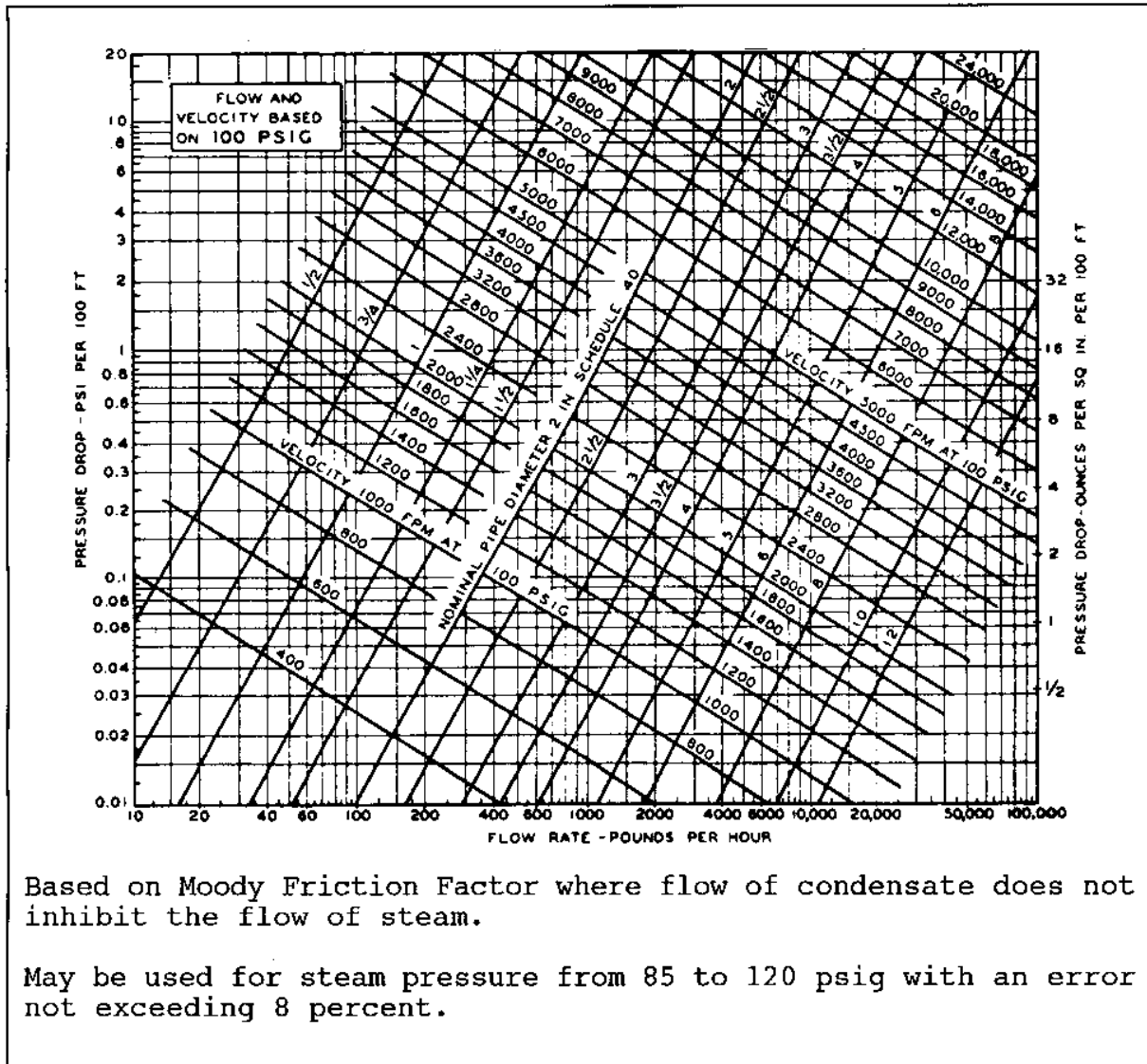

Figure 20  
 Chart for Flow Rate and Velocity of Steam in Schedule 40  
 Pipe Based on Saturation Pressure of 100 psig

Reprinted by permission of ASHRAE, from ASHRAE Handbook, Fundamentals.

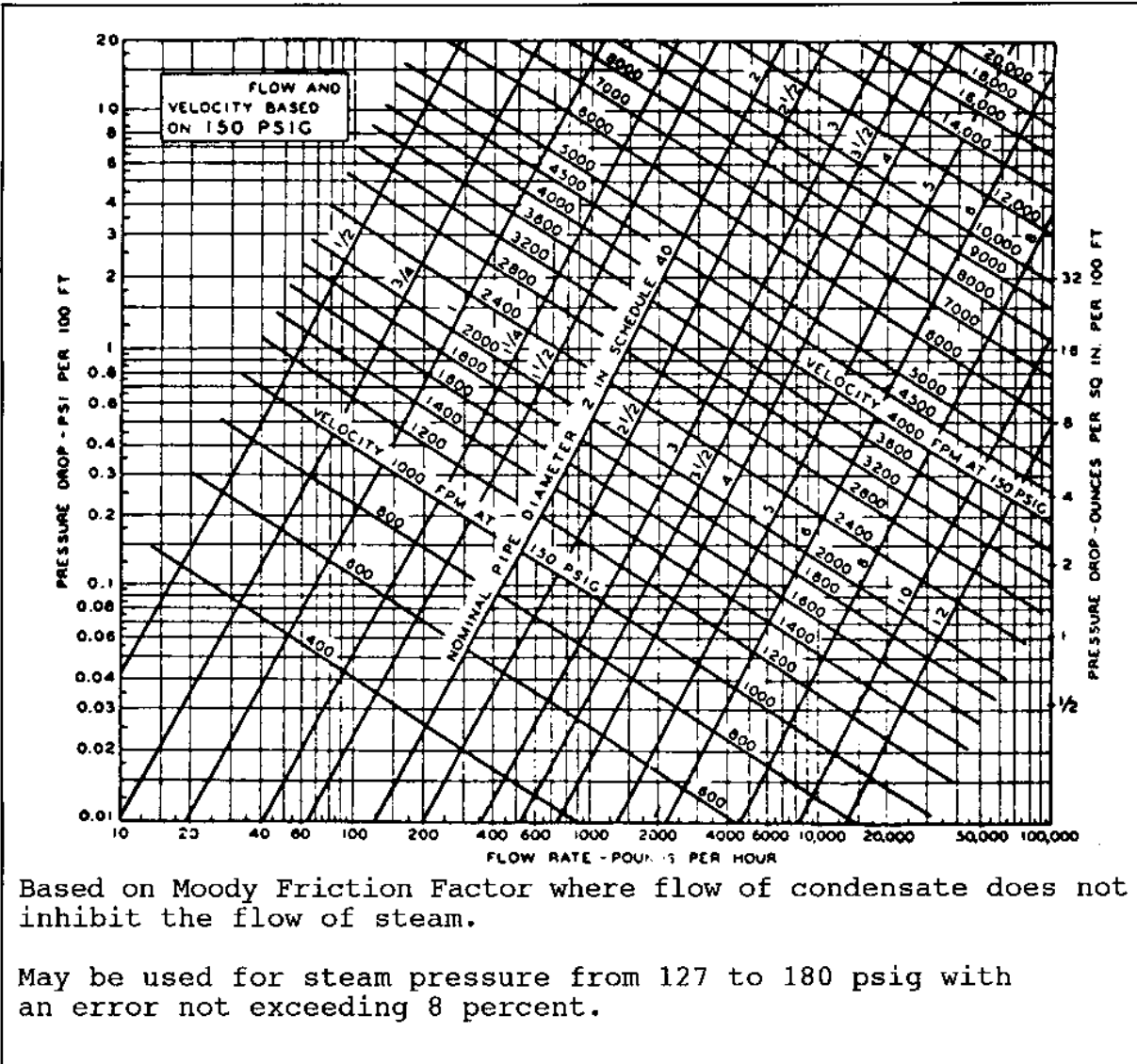

Figure 21  
 Chart for Flow Rate and Velocity of Steam in Schedule 40  
 Pipe Based on Saturation Pressure of 150 psig

b) Do not use vacuum condensate returns. Since high pressure steam is hotter than low pressure steam, provide adequate cooling legs of uninsulated steam pipe or a length of finned radiation between the last steam main takeoff and the drip assembly. Failure to do this will cause the hot condensate to flash back into steam at the trap. Use vented flash tank as a solution. Refer to par. 7.3.3.5 for condensate pumps and flash tank.

7.3.3.2 Boiler. Refer to MIL-HDBK-1003/6.

7.3.3.3 Heat Exchanger. Refer to par. 7.2.2.5.

7.3.3.4 Steam Pressure Regulating Valves. See Figures 22 and 23 for piping of steam pressure regulating assemblies, and note the following:

a) Sizing Pressure Regulating Valves

(1) Analyze flow required for maximum and minimum demand.

(2) Size the pressure regulating valve to handle peak flow. This will generally result in a valve body that is smaller than inlet supply line size.

(3) If there is a big turndown ratio between minimum and maximum flow, consider using two regulator valves in parallel, perhaps sized for 30 percent and 70 percent of the flow. Consider to flip the settings so that the small regulator pilot maintains optimum downstream pressure in the summer and the big regulator pilot is the lead controller in the winter.

(4) Look at the manufacturer's tables to see whether a two stage assembly should be used with two regulators in series. Sometimes this is done anyway for redundancy in low pressure installations; with the downstream regulator controlling to 5 psi, and an upstream regulator set at 7 psi in case the downstream regulator cannot handle a flow surge.

b) Piping Pressure Regulating Valves

(1) Provide a bypass around the regulator with a globe valve that has a tight shutoff seat. Size bypass to flow less than wide open failure flow of the regulator, but not less than regulator design flow.

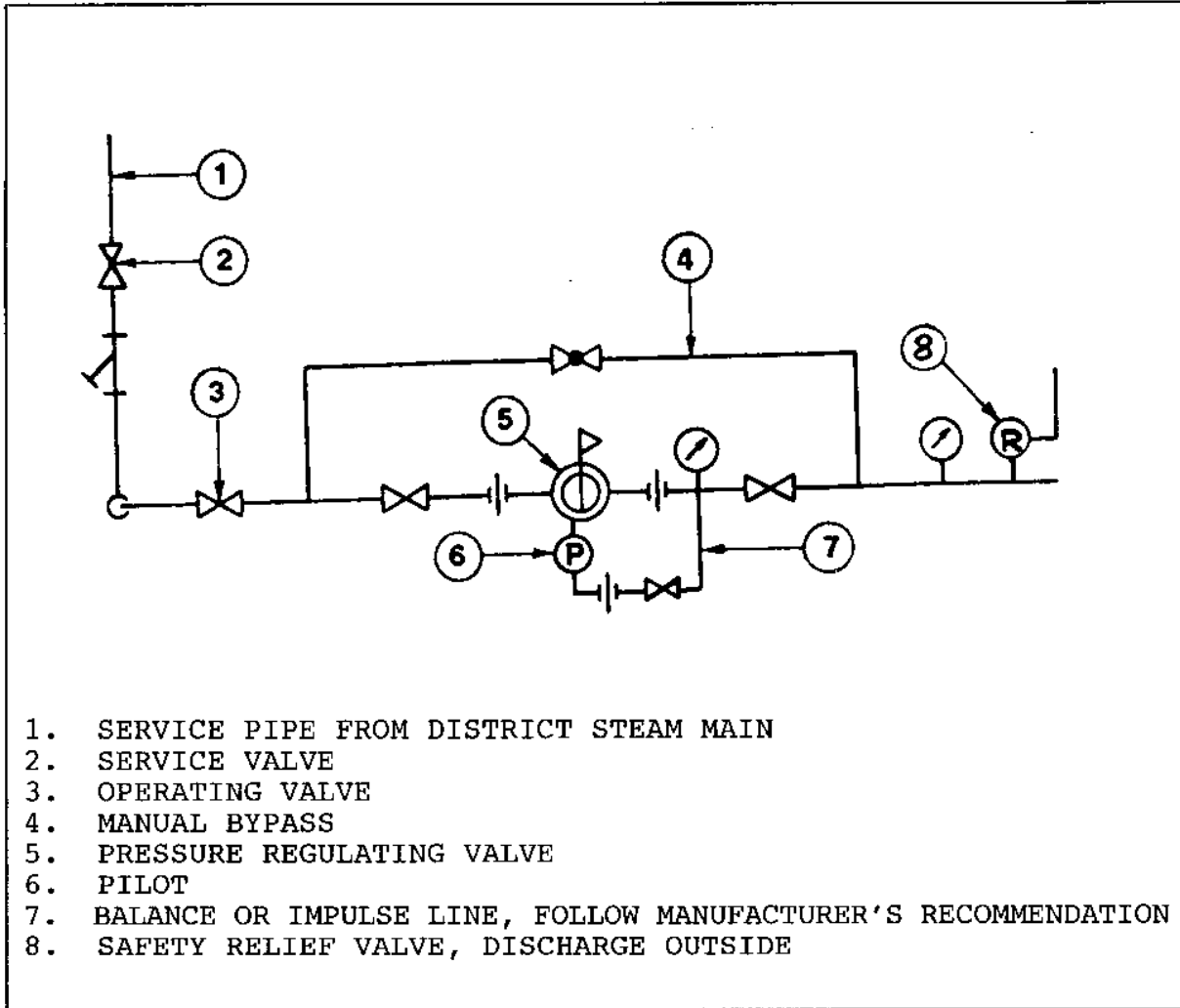

Figure 22  
PRV--Low Pressure

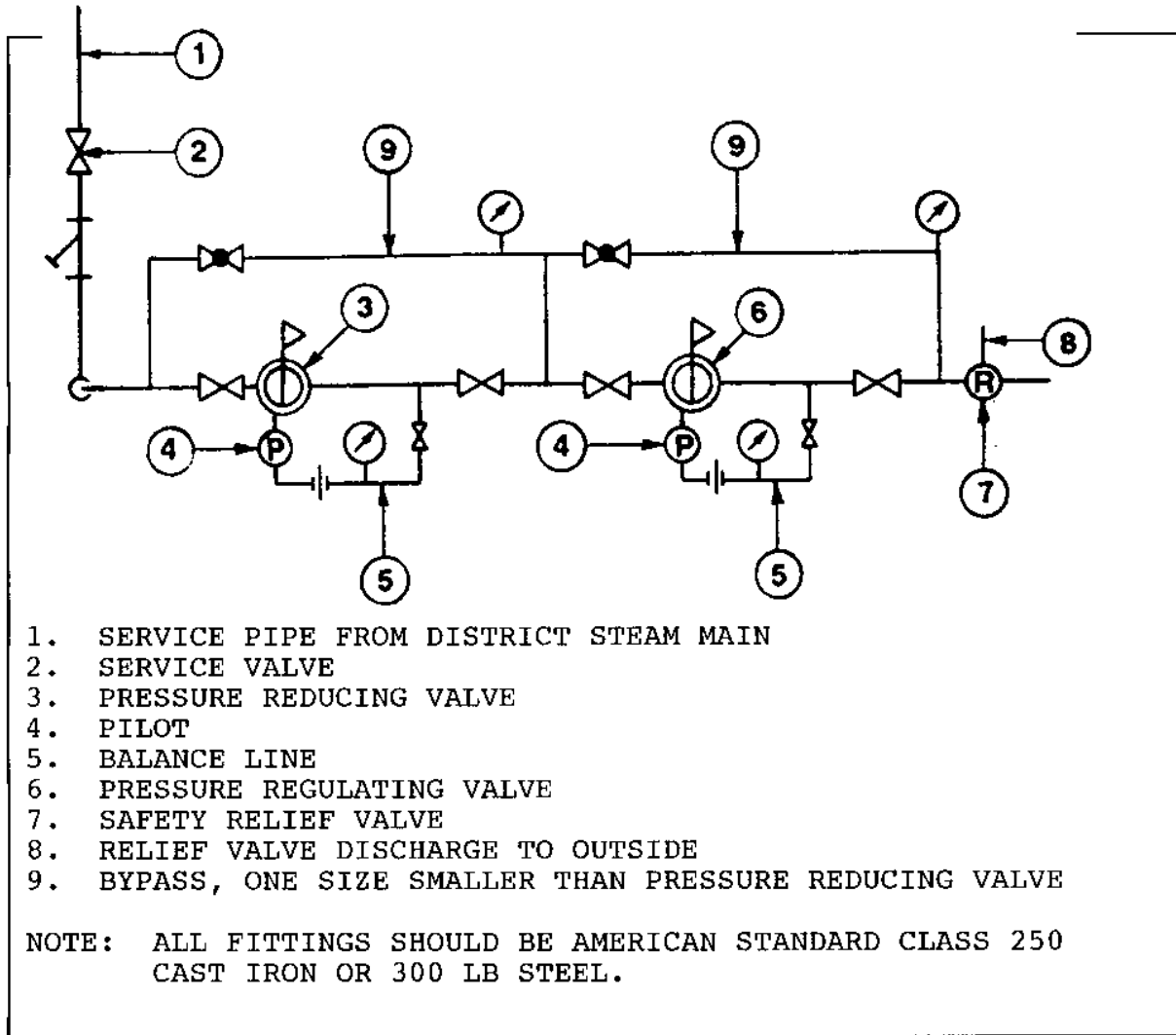

Figure 23  
 Two Stage PRV



(2) Put a pressure gage immediately downstream of the regulator pilot tap. The pressure gage range should include the upstream inlet pressure.

(3) Provide a relief valve on the downstream side that will handle 150 percent of the wide open failure flow rating of the regulator. Set the relief valve higher than the downstream operating pressure, and pipe the relief valve discharge to a safe place.

(4) Provide shutoff valves on each side of the regulator assembly; with the low side shutoff valve downstream of the pilot tap.

(5) Locate the entire regulator assembly in an accessible place.

7.3.3.5 Condensate Pumps and Flash Tank. Higher pressure steam condensate is hotter than low pressure steam condensate. If the system is over 40 psi steam, always run the condensate through a flash tank before entering the receiver of the condensate pump set. This prevents the condensate flashing to steam in the pumps. See Figure 24.

7.3.3.6 Steam Coils - General. Refer to par. 7.2.2.2 and the manufacturer's capacity tables for selection. See Figures 25 and 26 for piping steam coils. Always provide steam traps for each coil section. Steam distributing coils feature a perforated distributing header inside the main coil construction.

7.3.3.7 Steam Traps. In a steam system, steam traps should be provided to remove condensate and gas from the steam supply as soon as it forms. Unless this is done:

- a) A slug of condensate can harm the system.
- b) Accumulation of CO<sup>2</sup> gas can cause corrosion.

See Table 14 for common types of steam traps and Figure 27 for piping of a low pressure drip.

7.3.4 Boilers. Size the steam boiler in accordance with the ASHRAE Equipment Handbook, and include building heating, process steam, domestic water heating, and pickup loads. See Figure 28 for piping a low pressure steam boiler.



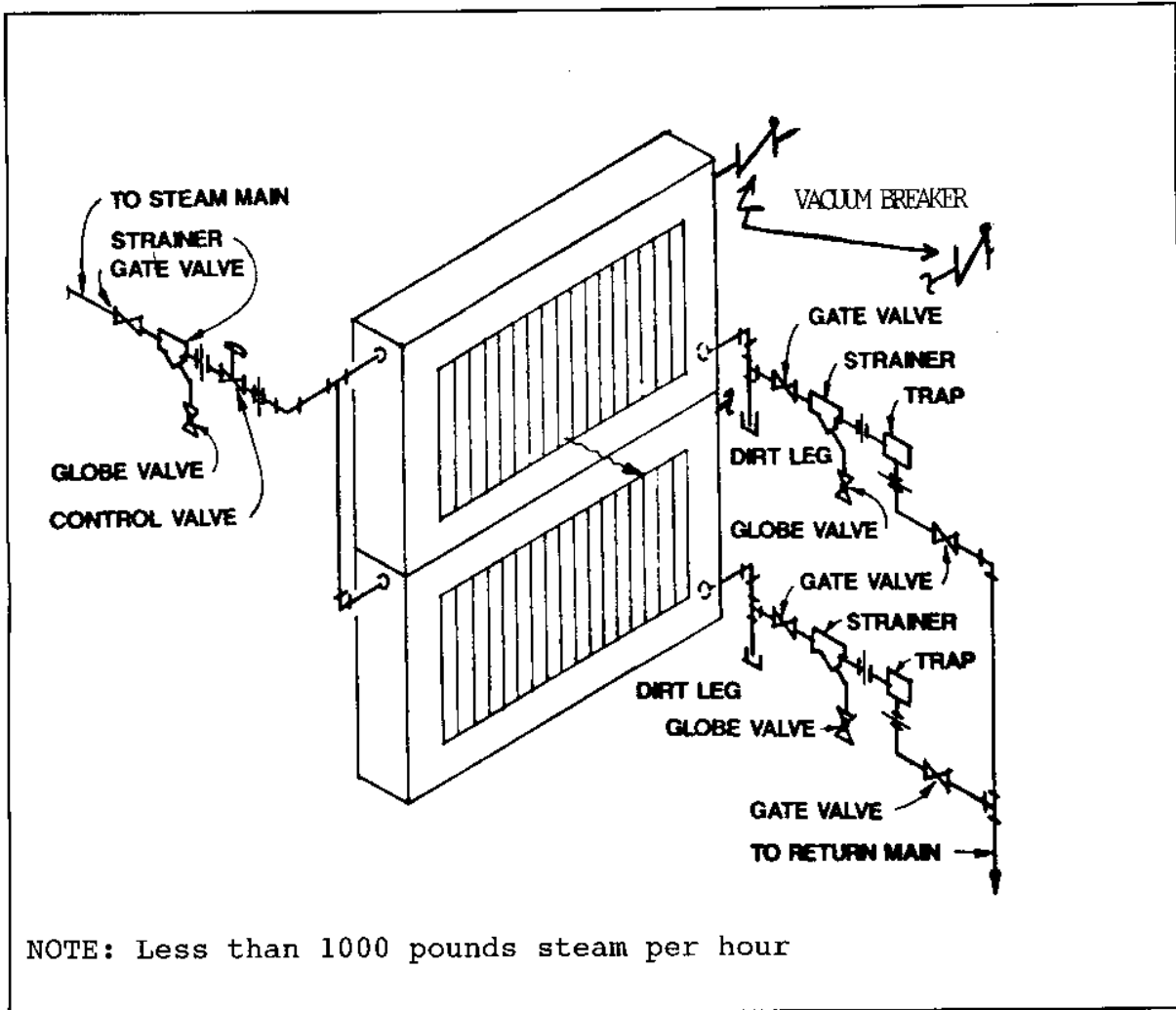

Figure 25  
Steam Coils

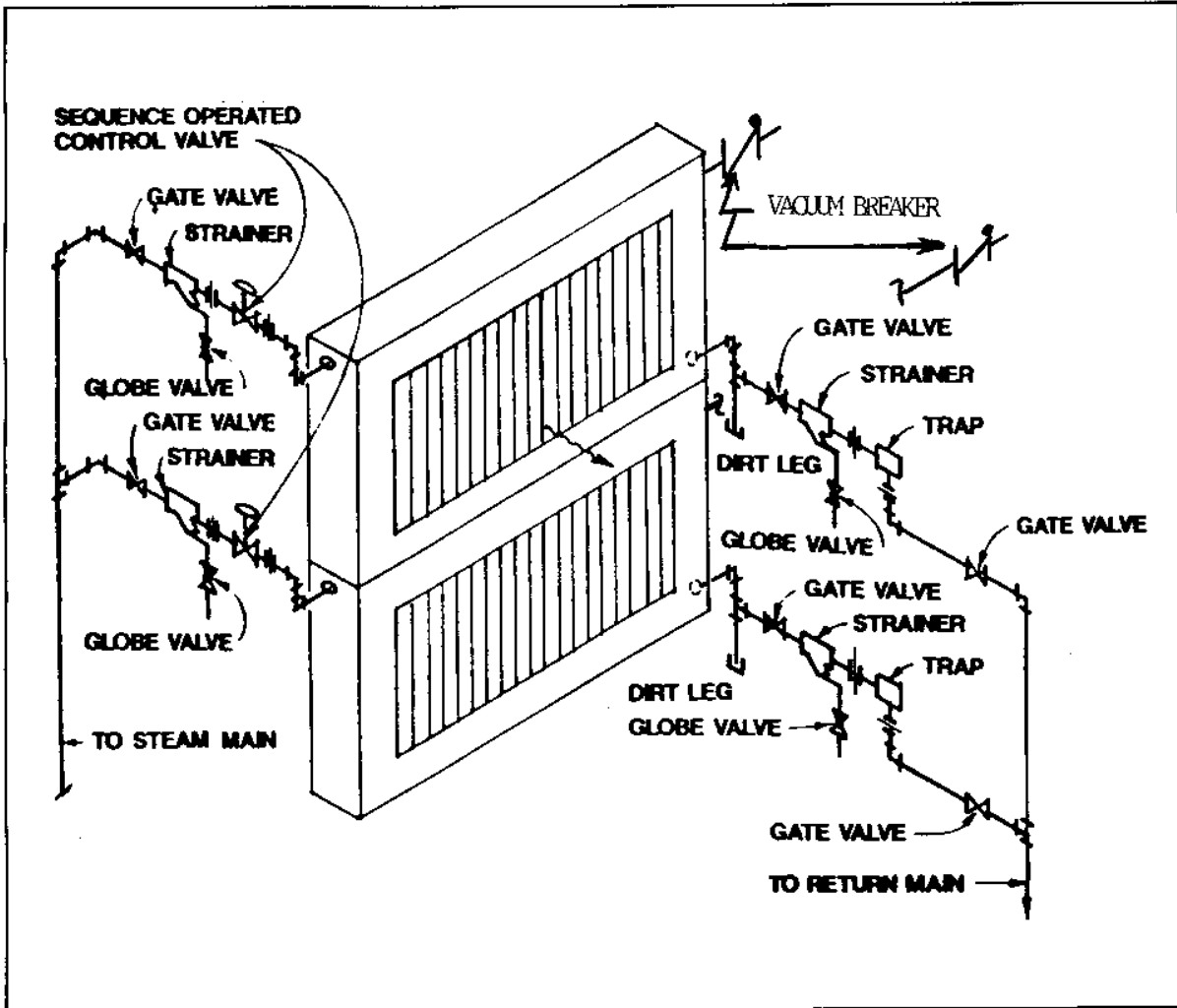

Figure 26  
Steam Tempering Coils

Table 14  
Common Types of Steam Traps

TYPE	APPLICATION
Bellows	Steady light loads in low pressure steam. Radiators, converters, etc.
Bimetallic Thermostat	High pressure steam where some condensate backup is tolerable; Steam tracing, jacketed piping, heat transfer equipment, etc.
Float and Thermostatic	Low pressure steam on temperature regulated coils; drips on steam mains; other large loads that vary where you cannot tolerate condensate backup.
Inverted Bucket	High and low pressure steam. HVAC and drips on steam mains.

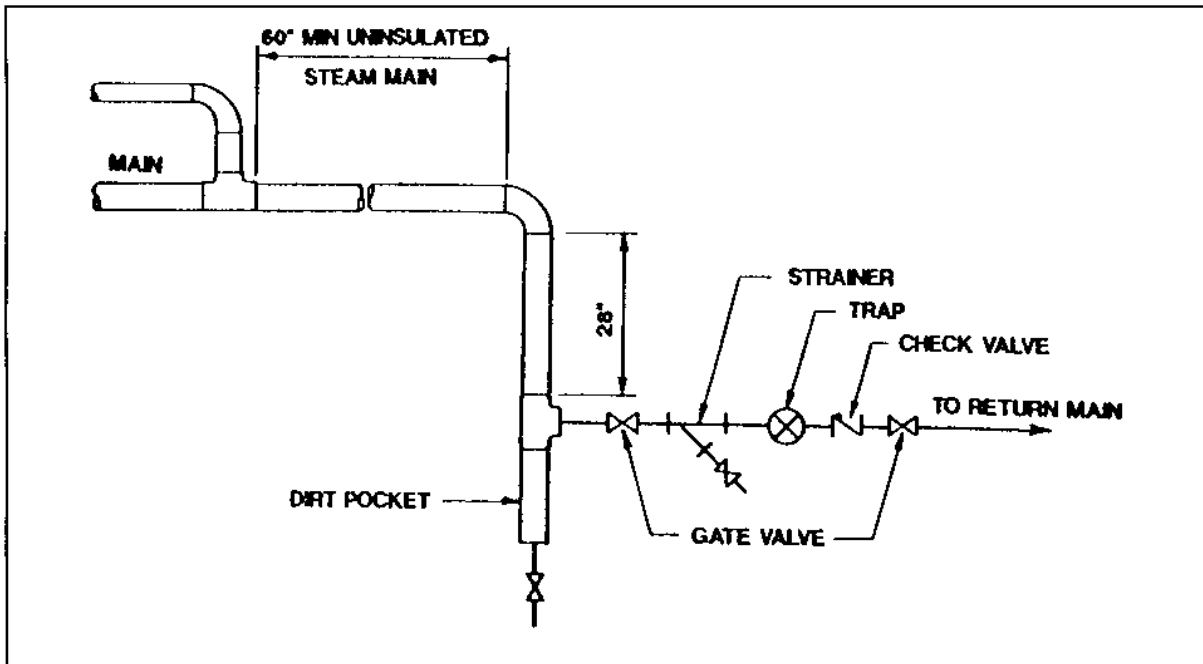

Figure 27  
Low Pressure Drip

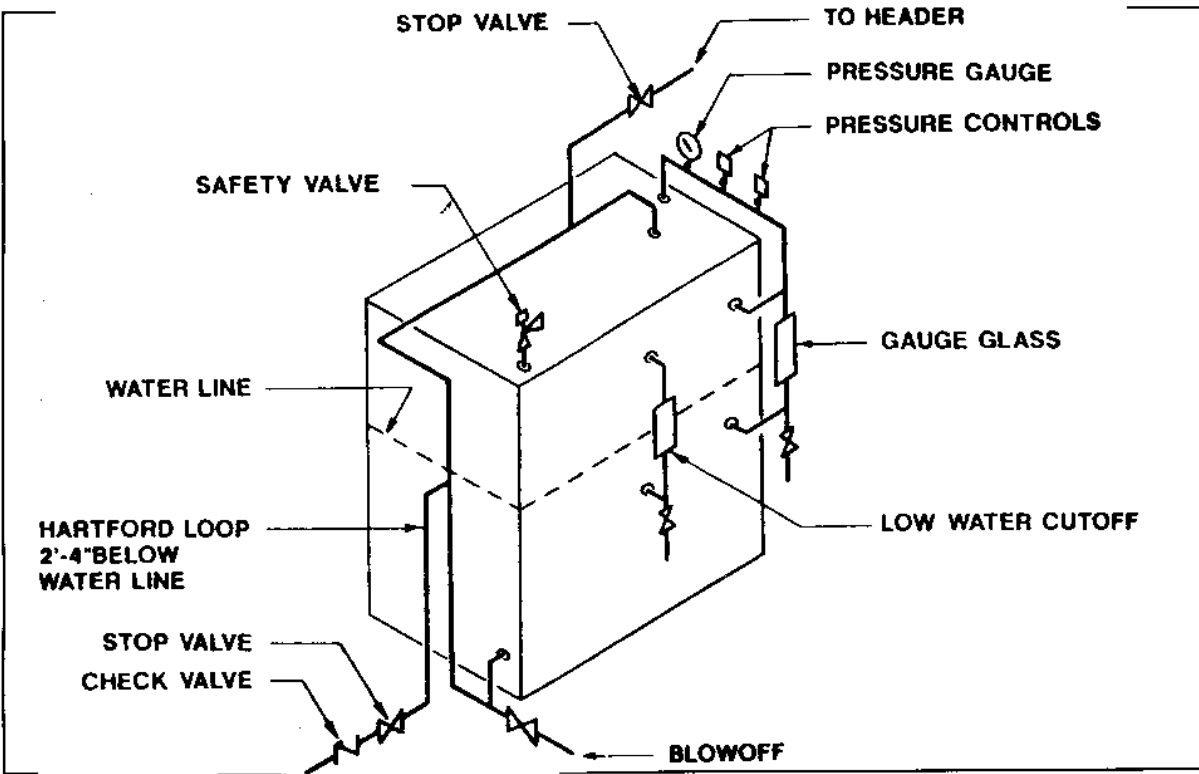

Figure 28  
Boiler Connections

7.3.5 Freezing of Steam Coils - General. Care should be taken in both design and construction of systems with steam heating coils to prevent coil freeze-up. Two primary causes of coil freeze-up are: (1) stratification of the air entering the coil due to poor mixing of outside air and return air, and (2) buildup of condensate in the coil. While it is virtually impossible to design a system with freeze-proof coils, careful consideration in the following areas could air in minimizing coil freezing problems.

7.3.5.1 Freezing Due to Air Stratification. See Figure 29. In general, outside air and return air are mixed in proportions that will provide an average mixed air temperature above freezing. However, if the outside air and return air streams are not thoroughly mixed, stratification of air can occur across the coil. This condition results in localized cold spots where sub-freezing air contacts the coil and can cause freezing. Care should be taken when locating the steam coil and designing the

mixing chamber to ensure proper mixing of outside air and return air. Figure 29 contains a sketch of a mixing plenum which is poorly designed for mixing of outside and return air and one properly designed to promote mixing of outside and return air.

7.3.5.2 Freezing Due to Buildup of Condensate in the Coil. See Figure 30 for coil piping to prevent freezing. There are a number of oversights in design and installation that can lead to buildup of condensate in a steam coil. These oversights primarily fall into the following categories:

a) Inappropriate Coil Selection. Many coil designs promote steam short circuiting - a phenomenon where steam takes the path of least resistance through coil tubes that have the least condensate flow. This increases the coil return header pressure to the point where the condensate in other coil tubes cannot drain properly. Coil designs have been developed to help minimize problems like this. The single row distribution tube and multi-row series flow coils minimize the potential for short-circuiting and trapping condensate inside the coil. These coil designs should be considered when designing a system where there is substantial risk of coil freezing.

b) Improper Installation. Even though the proper coil is selected, where the coil is not installed properly, freezing can still occur. Many coils are installed in such a way that gravity drainage is not possible. Though initially installed properly, coils can move into an undesirable position through building settling or weakening of supports. Closely inspecting coil installations with these problems in mind can help avoid problems in this area.

c) Improper Venting, Vacuum Elimination, and Steam Trapping Practices. If a coil is not designed for proper venting of noncondensables, vacuum elimination, and condensate removal, a well selected and installed coil can still experience problems with condensate buildup. Consider carefully proper steam piping practices in these areas and consult available Navy and industry guidance.

d) Modulating Valves. Avoid using modulating valves for control of preheat coils.

e) Traps. Trap each coil separately. Coils seldom have equal pressure drops.

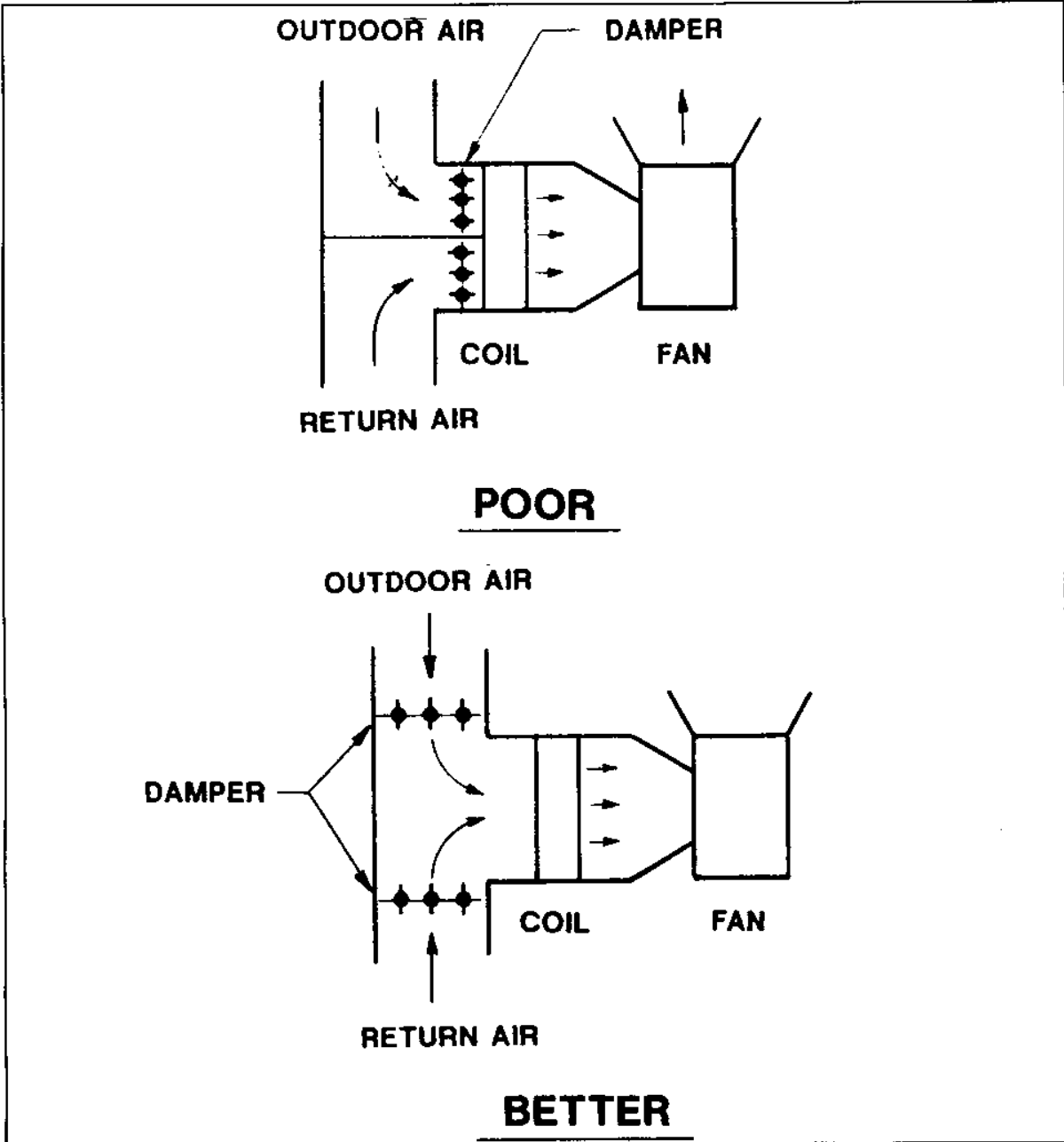

Figure 29  
Air Stratification to Coil During Freeze-Up Conditions



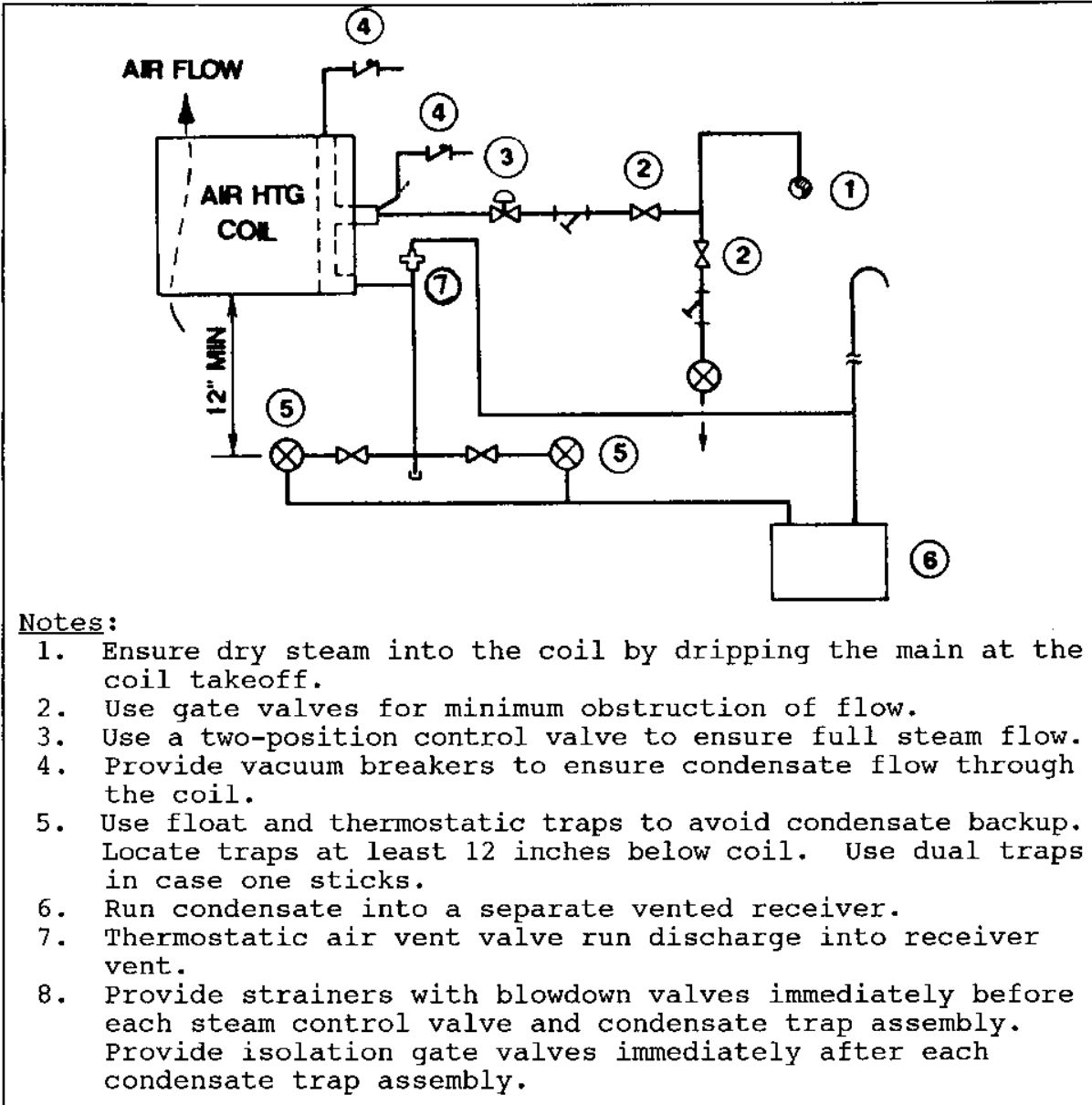

Figure 30  
Nonfreeze Coil Piping

7.3.6 Refrigerant Piping

7.3.6.1 General. This military handbook covers only direct expansion systems for HVAC systems. There is an entire ASHRAE Handbook devoted to food and industrial refrigeration. Refrigerant piping is slightly different from other piping because refrigerant gas is difficult to contain, so that special fittings (wrought copper or forged brass) and high melting point solder (1,000 degrees F) are needed to achieve a tight system, and provision must be made to ensure oil return to the compressor.

7.3.6.2 Sizing. See the ASHRAE Handbook, Refrigeration for flow rate charts on sizing the liquid, suction, and hot gas lines with various refrigerants.

7.3.6.3 Arrangement. See Figures 31 and 32 for refrigerant piping arrangement.

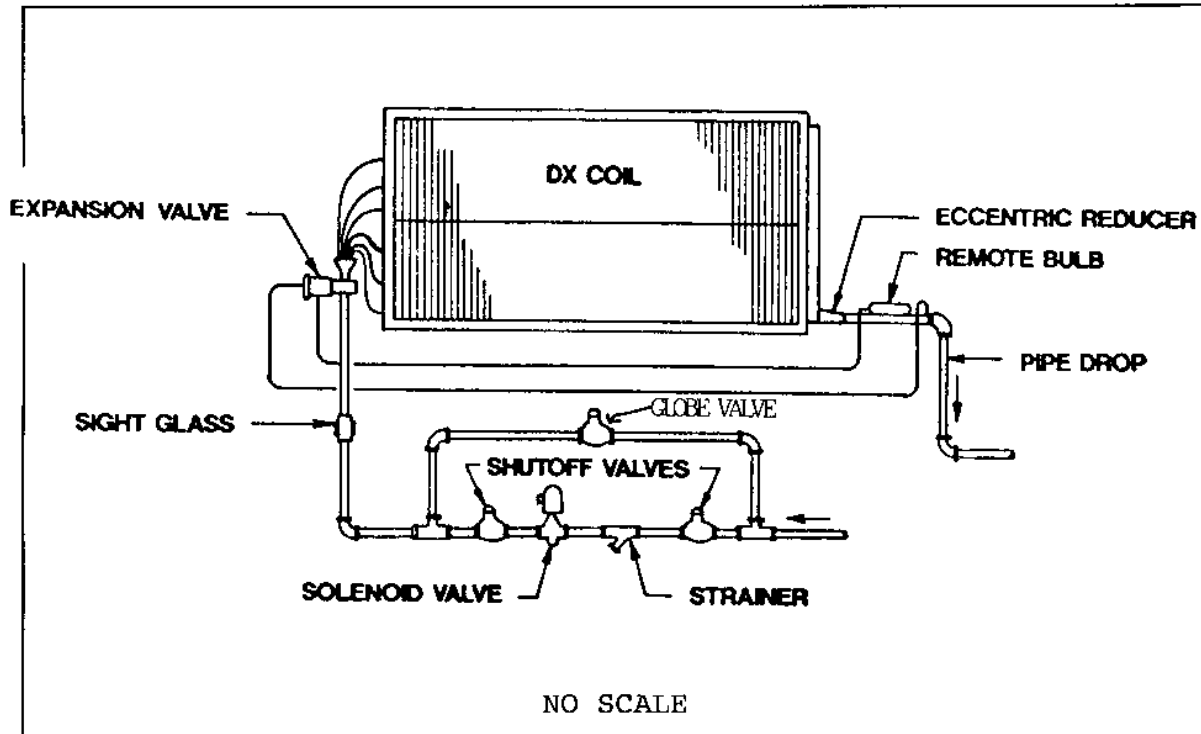

Figure 31  
Refrigerant Coil

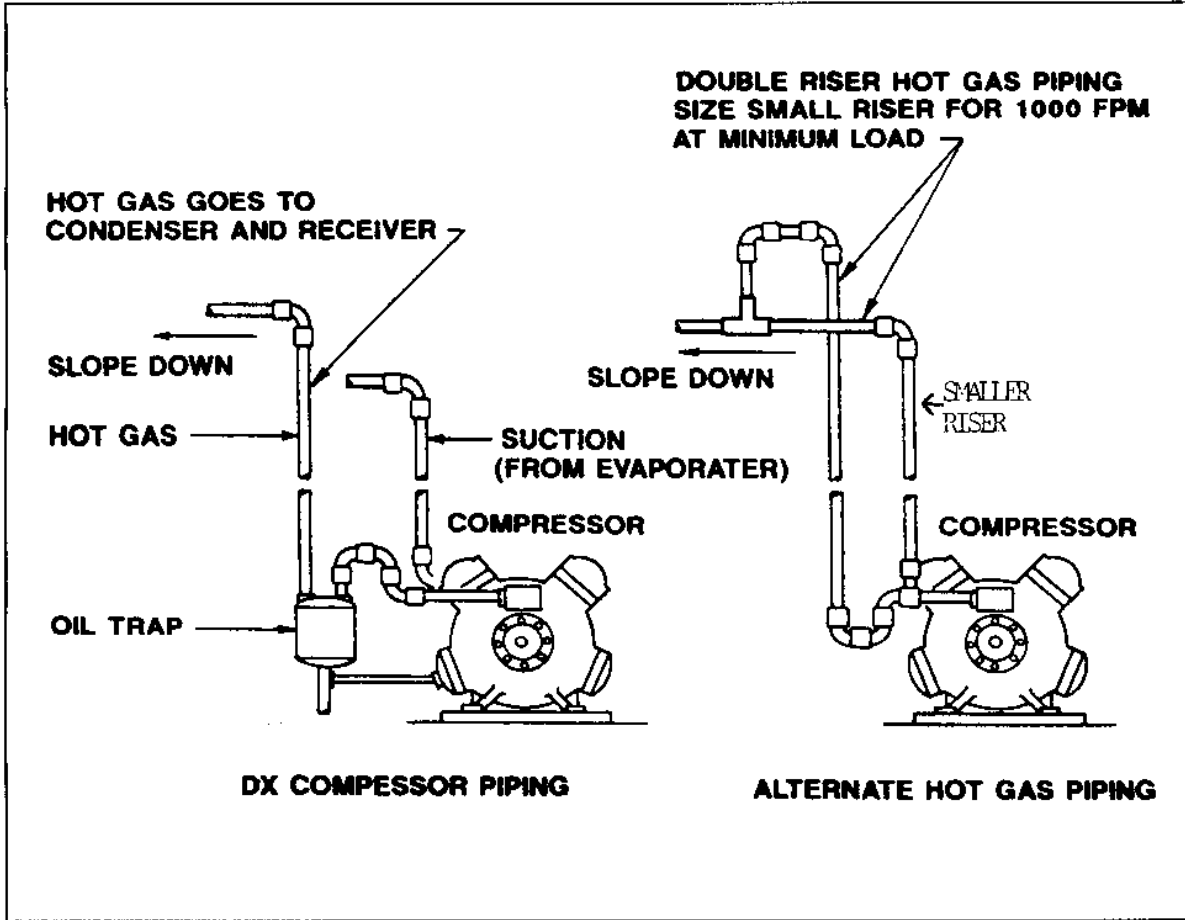

Figure 32  
Compressor Piping

## Section 8: CONTROLS AND INSTRUMENTATION

8.1 General Requirements. See pars. 2.2.6 and 2.2.8 for an overview of temperature controls and instrumentation. Another source of assistance that the designer may use is NFESC, Code ESC23 at Port Hueneme, California. NFESC is a Navy organization that has expertise in direct digital control (DDC) applications.

8.1.1 Choice of Controls. DDC is the control system of choice for HVAC systems. Consider the advantages of DDC for new and major renovation projects. Older conventional control systems may be specified for small buildings where DDC is not cost effective or where the customer refuses to accept DDC. Use of pneumatic controllers is discouraged because of the high maintenance required to keep them functional. Existing pneumatic operators may be reused, if in good operating condition, as part of a hybrid system with DDC sensors and controllers and the pneumatic operators.

8.1.1.1 A Guide to Choose Control Systems. Consider the following when selecting the type of control system (digital, electric, analog electronic, or pneumatic):

a) Life cycle cost. In most cases, DDC will be the lowest cost on a life cycle cost basis. The first cost of DDC and conventional control systems may be comparable but DDC operating and maintenance costs are significantly lower.

b) Customer preference of control type. The customer may feel that his personnel are better qualified to operate and maintain a particular type control system. Repair parts may be an important consideration.

8.1.1.2 Factors to Select Control Systems. Control selection may be determined by several factors as follows:

a) DDC systems use stand-alone digital controllers, distributed throughout the building to provide control of HVAC functions. The digital controller replaces conventional receiver controllers, thermostats, switches, relays, and auxiliary devices. Sensors are wired directly to the digital controller, which performs the control logic in software, and outputs a control signal directly to the actuator or relay. Terminal control units control individual terminal HVAC equipment, such as VAV boxes, fan coil units, and heat pumps. Distributed control refers to locating the digital controllers near the equipment being controlled.

b) DDC systems require less maintenance than conventional control systems. With a personal controller (PC) interface workstation, HVAC mechanics can quickly troubleshoot HVAC problems. DDC systems efficiently operate building HVAC systems by providing accurate sensing, maintaining setpoints, and operating in the designed sequence.

c) One disadvantage of DDC is that DDC systems from different manufacturers have different operating systems which are proprietary and will not communicate with each other. In some cases, this makes competitive bids for additions difficult.

d) Consider specifying DDC in the following situations:

- (1) In most new construction,
- (2) In a major retrofit of HVAC systems,
- (3) When complex or numerous HVAC systems are included in the design,
- (4) In buildings over 20,000 square feet,
- (5) When remote or local workstation monitoring and troubleshooting of HVAC equipment is desired, and
- (6) When the customer desires DDC.

e) Acceptance of DDC by the user's operation and maintenance personnel is extremely important. If not so accepted, DDC should not be specified. The project manager should directly contact station personnel to make this determination of acceptance.

f) Consider conventional electric, analog electronic, or pneumatic control systems when the following apply:

- (1) Small buildings where DDC is not cost effective,
- (2) When package air handling units are specified, and
- (3) When the customer or maintenance will not support DDC.

8.1.2 Designing DDC Systems. Design DDC systems using the following guidance:

a) Keep the input and output points to the minimum number required for HVAC control and efficient building operation. Follow the recommended point guidance provided in par. 8.2. Follow the principle to "Keep it Simple."

b) Use standard control sequences for similar HVAC control system applications.

c) Show the following on control drawings as a minimum:

(1) Flow diagram schematic of each mechanical system showing sensors, equipment, and operators.

(2) Individual point list description for each mechanical system.

(3) Electrical ladder diagram for each electrical circuit controlled.

(4) Operating parameters - controller setpoints and time schedules.

(5) Detailed sequence of operation.

d) Use direct connection of temperature sensors when possible. Use only precision thermistors (10,000 ohms) for room sensing and 1000 ohm platinum RTDs for HVAC unit sensing.

e) Use room zone temperature sensors with pushbutton override and setpoint adjustment integral to the sensor.

f) Do not modify the chiller microprocessor system supplied with the equipment. Control and safety functions should be the chiller manufacturer's responsibility. The DDC system should only enable or disable the chiller, chilled water pump, condenser water pump, and in some cases chilled water and condenser water reset. For chillers 150 tons and larger, provide an RS-485 communication between the chiller microprocessor and the DDC system.

g) Do not modify the boiler microprocessor system supplied with the equipment. Control and safety functions should be the boiler manufacturer's responsibility. Design hot water systems to maintain the boiler manufacturer's minimum temperature when in operation but vary the hot water supply temperature as required to meet the building's requirements.

h) Connect steam, high temperature hot water, gas, and electric meters to the DDC for remote monitoring of energy use of the building.

## 8.2 Standard Sequences of Operations

8.2.1 General Requirements. These requirements shall apply to primary HVAC systems unless modified herein. The sequences describe actions of the control system in one direction of change in the HVAC process analog variable, such as temperature, humidity, or pressure. The reverse sequence shall occur when direction of change is reversed unless specifically modified.

8.2.2 Operation of HVAC System. Equipment shall be operated in the optimized start, occupied, or unoccupied modes.

a) The optimized start mode energizes the equipment at maximum capacity at the latest time required for heating up (or cooling down) the space to normal occupied temperature conditions.

b) The occupied mode maintains the occupied conditions under all load variations while providing required ventilation. Supply fan operates continuously.

c) The unoccupied mode cycles the equipment to maintain a minimum heating temperature (or a maximum cooling temperature) in the space while providing no ventilation.

## 8.2.3 Operation of Outside Air, Return Air, and Exhaust (Relief) Air Dampers

a) Optimized Start Mode: Outside air and exhaust air dampers are closed and return air dampers are opened.

b) Occupied Mode: Outside air dampers are opened to the minimum ventilation air position. If an economizer outside air cycle is provided, the outside air, return air, and exhaust air dampers are automatically controlled. An outdoor air dry bulb sensor disables the economizer cycle and maintains minimum ventilation air when the outside air dry bulb temperature exceeds the changeover point.

c) Unoccupied Mode: Outside air and exhaust air dampers are closed and return air dampers are opened.

8.2.4 Operation of Filtration System. Differential pressure sensor measuring static pressure drop across the filter shall initiate alarm when pressure drop exceeds recommended value.



8.2.5 Operation of Freeze Protection. A freezestat with an extended surface sensing element, located ahead of the chilled water coil, shall stop the supply fan, return system components to their fail-safe position, and initiate a low-temperature alarm if the temperature at any point of the sensing element falls below the setpoint. Normal operation will occur only after the freezing condition is corrected and the freezestat is manually reset.

8.2.6 Operation of Smoke Detectors. Duct type smoke detectors located in the supply fan discharge air duct and in the return air duct (as required by NFPA) shall stop the supply fan, return system components to their fail-safe position, and shall activate the smoke alarm if either detector senses the presence of smoke. Normal operation will occur only after the smoke is cleared and the detector(s) is manually reset.

8.2.7 Operation of Chilled Water Coil Discharge Control. A dry bulb temperature sensor located in the chilled water coil discharge air shall, on a rise in temperature, first, gradually close the preheat coil valve, next, gradually open the outside air damper from its minimum ventilation air position while simultaneously gradually close the return air damper (ensure thorough mixing) and gradually opening the exhaust air damper, and then gradually open the chilled water coil valve. An outdoor air dry bulb sensor disables the economizer cycle and maintains minimum ventilation air when outside air dry bulb temperature exceeds the changeover point.

8.2.8 Operation of Preheat Coil Control. (Where required by outdoor design temperatures and ventilation air requirements.) A dry bulb temperature low limit sensor located in the mixed air (ensure thorough mixing) shall, on a fall in temperature, gradually open the preheat coil valve. Primary control shall be sequenced by the chilled water coil discharge sensor or supply air sensor.

8.2.9 Operation of Heating Coil Control. A dry bulb temperature sensor located in the heating coil discharge air shall, on a rise in dry bulb air temperature, gradually close the heating coil valve.

8.2.10 Operation of Space Control (Single Zone Unit). A room type dry bulb temperature sensor located in the most critical spot shall, on a rise in dry bulb temperature in the space, first gradually close the heating coil valve, next gradually close the preheat coil valve, then gradually open the outside air damper from its minimum ventilation air position while simultaneously gradually close the return air damper (ensure thorough mixing)

and gradually opening the exhaust air damper, and finally gradually open the chilled water coil valve. A dry bulb temperature low limit sensor located in the mixed air (ensure thorough mixing) shall, on a fall in temperature, gradually open the preheat coil valve. An outdoor air dry bulb sensor disables the economizer cycle and maintains minimum ventilation air when outside air dry bulb temperature exceeds the changeover point.

8.2.11 Operation of Space Control (Multizone Unit). A room type dry bulb temperature sensor located in the most critical spot shall, on a rise in dry bulb temperature in the space, gradually open the cold deck damper while simultaneously gradually close the hot deck damper.

8.2.12 Operation of Space Control (VAV Terminal Unit - Pressure Dependent). A room type dry bulb temperature sensor located in the most critical spot shall, on a rise in dry bulb temperature in the space, gradually open the VAV terminal box cold air valve.

8.2.13 Operation of Supply Duct Pressure Control. A supply duct static pressure sensor located two-thirds the distance from the fan of the length of the longest supply duct run shall, on a rise in static pressure, gradually reduce the speed of the electric motor variable speed drive and close the fan vortex damper. A high-limit duct static pressure sensor located at the fan discharge shall override the supply duct static pressure sensor to limit pressures to design values.

8.3 Single Zone Unit Sequence of Operations (Sample). See Figure 33 and Table 15.

a) General: Sequences describe actions of the control system in one direction of change in the HVAC process analog variable, such as temperature, humidity, or pressure. Reverse sequence shall occur when direction of change is reversed unless specifically modified.

b) Optimized Start Mode: Energize equipment at maximum capacity at the latest time required for heating up (or cooling down) the space to normal occupied temperature conditions. Outside air and exhaust air dampers are closed and return air dampers are opened.

c) Occupied Mode: Maintain occupied conditions under load variations while providing required ventilation. Supply fan operates continuously. Outside air dampers are opened to the minimum ventilation air position. If an economizer outside air cycle is provided, the outside air, return air, and exhaust air

dampers are automatically controlled. An outdoor air dry bulb sensor disables the economizer cycle and maintains minimum ventilation air when outside air dry bulb temperature exceeds the changeover point.

d) Unoccupied Mode: Cycle the equipment to maintain minimum heating temperature (or maximum cooling temperature) in the space while providing no ventilation. Outside air and exhaust air dampers are closed and return air dampers are opened.

e) Maintenance and Safety Mode: A differential pressure sensor measuring static pressure drop across the filter shall initiate an alarm when the pressure drop exceeds the recommended value.

A freezestat with extended surface sensing element located ahead of the chilled water coil shall stop the supply fan, return system components to their fail-safe position, and initiate a low-temperature alarm if the temperature at any point of the sensing element falls below the setpoint. Normal operation shall occur only after the freezing condition is corrected and the freezestat is manually reset.

f) Room Control Mode: A room type dry bulb temperature sensor located in the most critical spot shall, on a rise in dry bulb temperature in the space, first gradually close the heating coil valve, next gradually close the preheat coil valve, then gradually open the outside air damper from its minimum ventilation air position while simultaneously gradually close the return air damper (ensure thorough mixing) and gradually opening the exhaust air damper, and finally gradually open the chilled water coil valve. A dry bulb temperature low limit sensor located in the mixed air (ensure thorough mixing) shall, on a fall in temperature, gradually open the preheat coil valve. A dry bulb temperature low limit sensor located in the supply air shall, on a fall in temperature, gradually open the heating coil valve. An outdoor air dry bulb sensor disables the economizer cycle and maintains minimum ventilation air when outside air dry bulb temperature exceeds the changeover point.

8.4 Multizone Unit Sequence of Operation (Sample). See Figure 34 and Table 16.

a) General: Sequences describe actions of the control system in one direction of change in the HVAC process analog variable, such as temperature, humidity, or pressure. Reverse sequence shall occur when direction of change is reversed unless specifically modified.



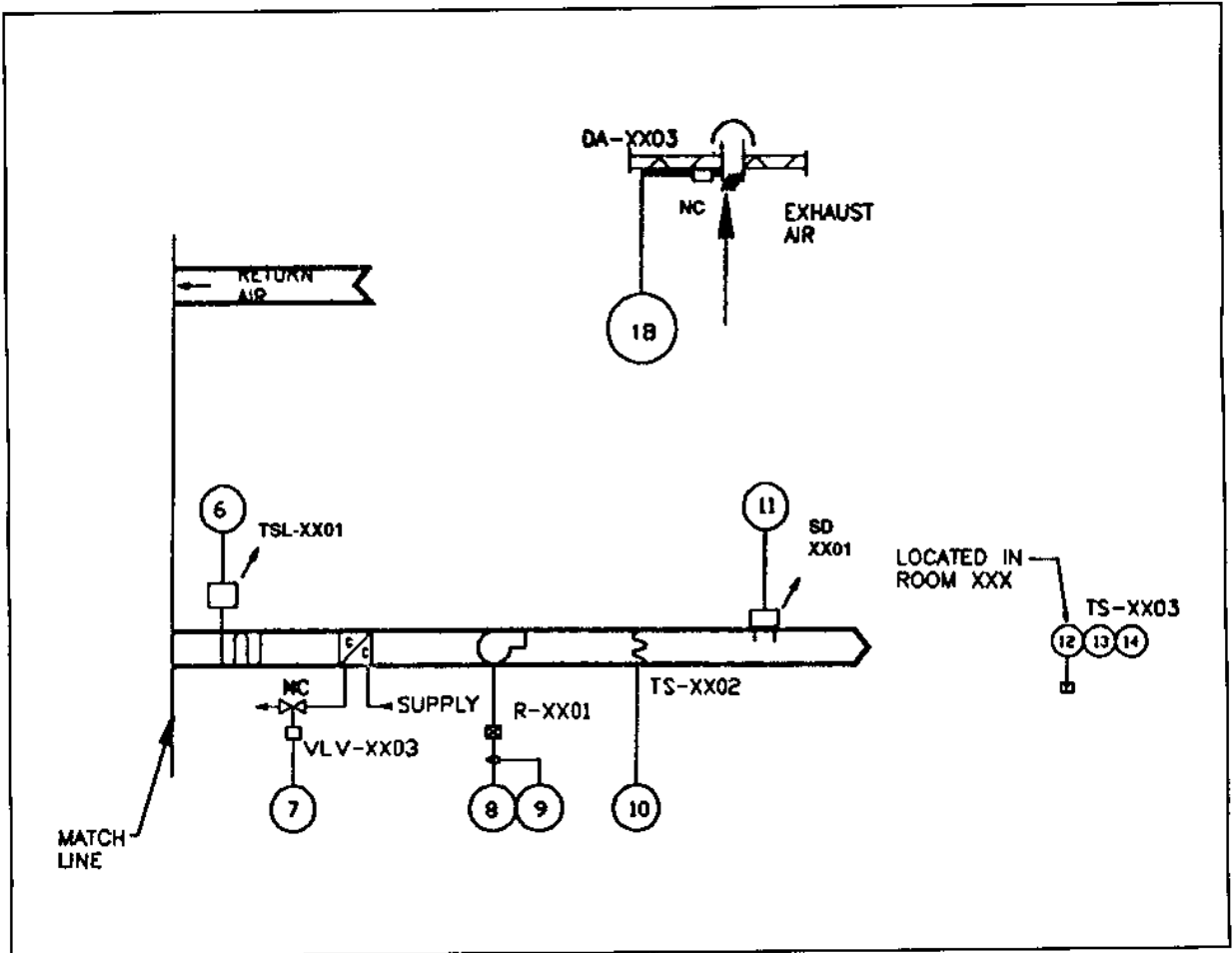

Figure 33 (Continued)  
 Control System Schematic for Single Zone HVAC System XX

Table 15  
Equipment for Single Zone HVAC Control System XX

LOOP CONTROL FUNCTION	DEVICE NUMBER	DEVICE FUNCTION	SETPOINT	RANGE	ADDITIONAL PARAMETERS
ROOM ZONE TEMPERATURE	DA-XX01, 02, 03	DAMPER ACTUATOR	--	4-20 ma	MIN.O.A. XXXX CFM
	--	OUTDOOR AIR DB HI LIMIT	65° F	--	SOFTWARE POINT
	TS-XX01	MIXED AIR LOW LIMIT TEMPERATURE SENSOR	55° F	30-130° F	--
	VLV-XX01	PREHEAT COIL VALVE	--	4-20 ma	CV-10 CLOSE AGAINST 16 PSIG
	TS-XX02	SUPPLY AIR	55° F	40-140° F	--
	VLV-XX02	HEATING COIL VALVE	--	4-20 ma	CV-12 CLOSE AGAINST 16 PSIG
	VLV-XX03	COOLING COIL VALVE	--	4-20 ma	CV-20 CLOSE AGAINST 20 PSIG
	TS-XX03	ROOM ZONE TEMPERATURE SENSOR	H-70° F C-76° F N-55° F	50-100° F	WITH SETPOINT ADJUSTMENT & OVERRIDE SWITCH
SAFETY & MAINTENANCE	TSL-XX01	LOW TEMPERATURE PROTECTION THERMOSTAT	35° F	--	--
	SD-XX01	SUPPLY AIR SMOKE DETECTOR	--	--	--
	SD-XX02	RETURN AIR SMOKE DETECTOR	--	--	--
	DP-XX01	FILTER STATUS DIFFERENTIAL PRESSURE	0.5 IN. W.G.	0-2 IN. W.G.	--

Table 15 (Continued)  
 Equipment for Single Zone HVAC Control System XX

LOOP CONTROL FUNCTION	DEVICE NUMBER	DEVICE FUNCTION	SETPOINT	RANGE	ADDITIONAL PARAMETERS
SAFETY & MAINTENANCE (CONT'D) SUPPLY FAN	TS-XX04	RETURN AIR TEMPERATURE SENSOR	--	50-100° F	--
	R-XX01	SUPPLY FAN START RELAY	--	--	--
	CS-XX01	SUPPLY FAN CURRENT SENSOR	--	--	--

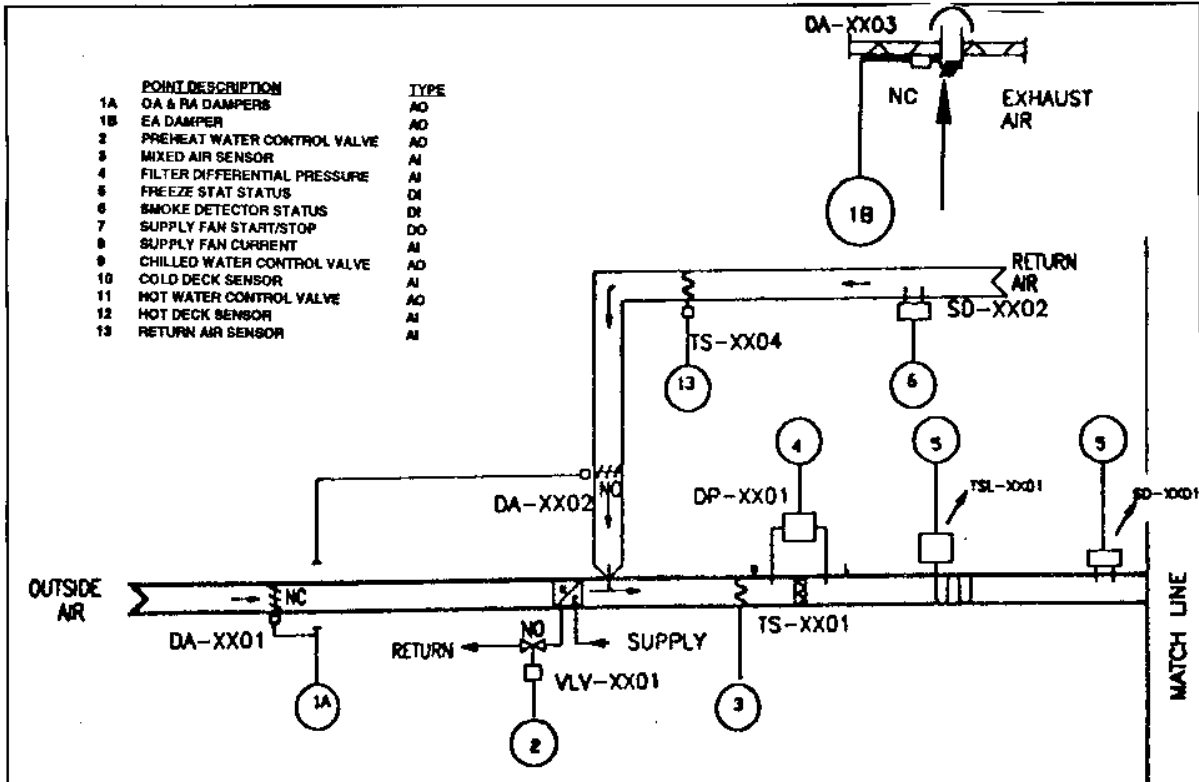

- | POINT DESCRIPTION              | TYPE |
|--------------------------------|------|
| 1A OA & RA DAMPERS             | AO   |
| 1B EA DAMPER                   | AO   |
| 2 PREHEAT WATER CONTROL VALVE  | AO   |
| 3 MIXED AIR SENSOR             | AI   |
| 4 FILTER DIFFERENTIAL PRESSURE | AI   |
| 5 FREEZE STAT STATUS           | DI   |
| 6 SMOKE DETECTOR STATUS        | DI   |
| 7 SUPPLY FAN START/STOP        | DO   |
| 8 SUPPLY FAN CURRENT           | AI   |
| 9 CHILLED WATER CONTROL VALVE  | AO   |
| 10 COLD DECK SENSOR            | AI   |
| 11 HOT WATER CONTROL VALVE     | AO   |
| 12 HOT DECK SENSOR             | AI   |
| 13 RETURN AIR SENSOR           | AI   |

Equipment for Multizone HVAC Control System XX

LOOP CONTROL FUNCTION	DEVICE NUMBER	DEVICE FUNCTION	SETPOINT	RANGE	ADDITIONAL PARAMETERS
COLD DECK TEMPERATURE	DA-XX01, DS, SS	DAMPER ACTUATOR	-	4-20 mA	MIN. O.A. XX03, O.P.
	-	OUTDOOR AIR DE FE LIMIT	88° F	-	SOFTWARE POINT
	TS-XX01	MIXED AIR LOW LIMIT TEMPERATURE SENSOR	88° F	88° to 158° F	-
	VLV-XX01	PREHEAT COIL VALVE	-	4-20 mA	CV-10 CLOSE AGAINST 18 PSIG
	TS-XX02	COLD DECK TEMPERATURE SENSOR	88° F	40° to 140° F	-
HOT DECK TEMPERATURE	VLV-XX02	COOLING COIL VALVE	-	4-20 mA	CV-20 CLOSE AGAINST 30 PSIG
	TS-XX03	HOT DECK TEMPERATURE SENSOR	180° F	40° to 240° F	-
ROOM SENSORS (RAK, TPK, R)	TS-XX04	ROOM TEMPERATURE SENSORS	67° F C/W, 64° F W/W	88° to 108° F	WITH SET POINT ADJUSTMENT AND OVERRIDE SWITCH
	DA-XX04	ZONE DAMPER ACTUATORS	-	4-20 mA	ONE PER ZONE
SAFETY AND MAINTENANCE	TSL-XX01	LOW TEMPERATURE PROTECTION THERMOSTAT	38° F	-	-
	SD-XX01	SUPPLY AIR SMOKE DETECTOR	-	-	-
	SD-XX02	RETURN AIR SMOKE DETECTOR	-	-	-
	DP-XX01	FILTER STATUS DIFFERENTIAL PRESSURE	0.3 INCH W.G.	0.2 INCHES W.G.	-
SUPPLY FAN	R-XX01	SUPPLY FAN START RELAY	-	-	-
	CS-XX01	SUPPLY FAN CURRENT SENSOR	-	-	-

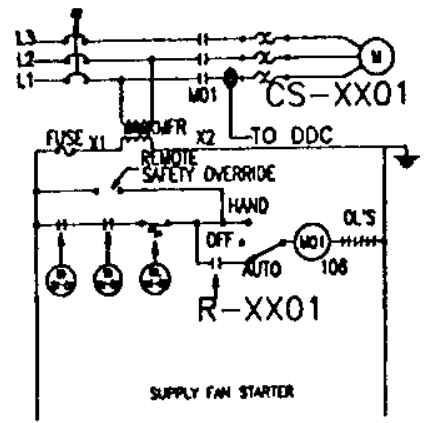

Figure 34 Control System Schematic for Multizone HVAC System XX



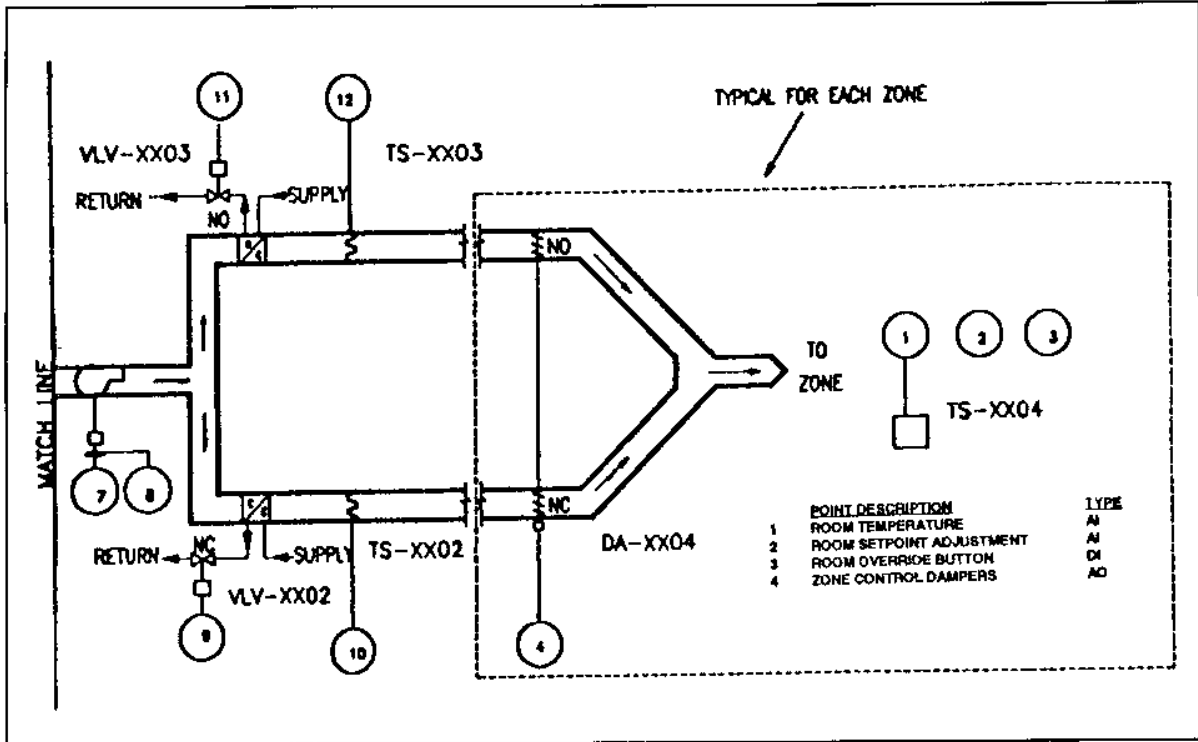

Figure 34 (Continued)  
Control System Schematic for Multizone HVAC System XX

Table 16  
Equipment for Multizone HVAC Control System XX

LOOP CONTROL FUNCTION	DEVICE NUMBER	DEVICE FUNCTION	SETPOINT	RANGE	ADDITIONAL PARAMETERS
COLD DECK TEMPERATURE	DA-XX01, 02, 03	DAMPER ACTUATOR	--	4-20 ma	MIN.O.A. XXXX CFM
	--	OUTDOOR AIR DB HI LIMIT	65 deg F	--	SOFTWARE POINT
	TS-XX01	MIXED AIR LOW LIMIT TEMPERATURE SENSOR	55 deg F	30-130 deg F	--

Table 16 (Continued)  
Equipment for Multizone HVAC Control System XX

LOOP CONTROL FUNCTION	DEVICE NUMBER	DEVICE FUNCTION	SETPOINT	RANGE	ADDITIONAL PARAMETERS
COLD DECK TEMPERATURE (CONT'D)	VLV-XX01	PREHEAT COIL VALVE	--	4-20 ma	CV-10 CLOSE AGAINST 16 PSIG
	TS-XX02	COLD DECK TEMPERATURE SENSOR	55° F	40-140° F	--
	VLV-XX02	COOLING COIL VALVE	--	4-20 ma	CV-20 CLOSE AGAINST 20 PSIG
HOT DECK TEMPERATURE	TS-XX03	HOT DECK TEMPERATURE SENSOR	180° F	40-240° F	
	VLV-XX03	HEATING COIL VALVE	--	4-20 ma	CV-12 CLOSE AGAINST 16 PSIG
ROOM SENSORS (MULTIPLE)	TS-XX04	ROOM TEMPERATURE SENSORS	H-70° F C-76° F N-55° F	50-100° F	WITH SETPOINT ADJUST- MENT & OVERRIDE SWITCH
	DA-XX04	ZONE DAMPER ACTUATORS	--	4-20 ma	ONE PER ZONE
SAFETY & MAINTENANCE	TSL-XX01	LOW TEMPERATURE PROTECTION THERMOSTAT	35° F	--	--
	SD-XX01	SUPPLY AIR SMOKE DETECTOR	--	--	--
	SD-XX02	RETURN AIR SMOKE DETECTOR	--	--	--
	DP-XX01	FILTER STATUS DIFFERENTIAL PRESSURE	0.5 IN. W.G.	0-2 IN. W.G.	--
	TS-XX04	RETURN AIR TEMPERATURE SENSOR	--	50-100° F	--

Table 16 (Continued)  
Equipment for Multizone HVAC Control System XX

LOOP CONTROL FUNCTION	DEVICE NUMBER	DEVICE FUNCTION	SETPOINT	RANGE	ADDITIONAL PARAMETERS
SAFETY & MAINTENANCE (CONT'D) SUPPLY FAN	TS-XX04	RETURN AIR TEMPERATURE SENSOR	--	50-100° F	--
	R-XX01	SUPPLY FAN START RELAY	--	--	--
	CS-XX01	SUPPLY FAN CURRENT SENSOR	--	--	--

b) Optimized Start Mode: Energize equipment at maximum capacity at the latest time required for heating up (or cooling down) the space to normal occupied temperature conditions. Outside air and exhaust air dampers are closed and return air dampers are opened.

c) Occupied Mode: Maintain occupied conditions under all load variations while providing required ventilation. Supply fan operates continuously. Outside air dampers are opened to the minimum ventilation air position. If an economizer outside air cycle is provided, the outside air, return air, and exhaust air dampers are automatically controlled. An outdoor air dry bulb sensor disables the economizer cycle and maintains minimum ventilation air when outside air dry bulb temperature exceeds the changeover point.

d) Unoccupied Mode: Cycle the equipment to maintain minimum heating temperature (or maximum cooling temperature) in the space while providing no ventilation. Outside air and exhaust air dampers are closed and return air dampers are opened.

e) Maintenance and Safety Mode: A differential pressure sensor measuring static pressure drop across the filter, shall initiate an alarm when the pressure drop exceeds the recommended value.

A freezestat with extended surface sensing element located ahead of the chilled water coil shall stop the supply fan, return system components to their fail-safe position, and initiate a low-temperature alarm if the temperature at any point

of the sensing element falls below the setpoint. Normal operation will occur only after the freezing condition is corrected and the freezestat is manually reset.

f) Chilled Water Coil Discharge Air Mode: A dry bulb temperature sensor located in the chilled water coil discharge air shall, on a rise in temperature, first gradually close the preheat coil valve, next gradually open the outside air damper from its minimum ventilation air position while simultaneously gradually close the return air damper (ensure thorough mixing) and gradually open the exhaust air damper, and then gradually open the chilled water coil valve. A dry bulb temperature low limit sensor located in the mixed air (ensure thorough mixing) shall, on a fall in temperature, gradually open the preheat coil valve. An outdoor air dry bulb sensor disables the economizer cycle and maintains minimum ventilation air when outside air dry bulb temperature exceeds the changeover point.

g) Heating Coil Discharge Air Mode: A dry bulb temperature sensor located in the heating coil discharge air shall, on a rise in dry bulb air temperature, gradually close the heating coil valve.

h) Room Control Mode: A room type dry bulb temperature sensor located in the most critical spot shall, on a rise in dry bulb temperature in the space, gradually open the cold deck damper while simultaneously gradually close the hot deck damper.

#### 8.5 Variable Air Volume (VAV) Unit Sequence of Operation (Sample). See Figure 35 and Table 17.

a) General: Sequences describe actions of the control system in one direction of change in the HVAC process analog variable, such as temperature, humidity, or pressure. Reverse sequence shall occur when direction of change is reversed unless specifically modified.

b) Optimized Start Mode: Energize equipment at maximum capacity at the latest time required for heating up (or cooling down) the space to normal occupied temperature conditions. Outside air and exhaust air dampers are closed and return air dampers are opened. Fans of series type VAV terminal units shall start.

c) Occupied Mode: Maintain occupied conditions under all load variations while providing required ventilation. Supply fan operates continuously. Outside air dampers are opened to the minimum ventilation airflow by the air monitoring unit for all

values of supply fan flow. If an economizer outside air cycle is provided, the outside air, return air, and exhaust air dampers are automatically controlled. An outdoor air dry bulb sensor disables the economizer cycle and maintains minimum ventilation air when the outside air dry bulb temperature exceeds the changeover point. Fans of series type VAV terminal units shall run continuously.

d) Unoccupied Mode: Cycle the VAV terminal units at maximum heating capacity to maintain minimum heating temperature in the space while providing no ventilation. Outside air and exhaust air dampers are closed and return air dampers are opened.

e) Maintenance and Safety Mode: A differential pressure sensor measuring static pressure drop across the filter shall initiate an alarm when the pressure drop exceeds the recommended value.

A freezestat with extended surface sensing element located ahead of the chilled water coil shall stop the supply fan, return system components to their fail-safe position, and initiate a low-temperature alarm if the temperature at any point of the sensing element falls below the setpoint. Normal operation will occur only after the freezing condition is corrected and the freezestat is manually reset.

f) Supply Fan Discharge Air Mode: A dry bulb temperature sensor located in the supply air fan discharge air shall, on a rise in temperature, first gradually close the preheat coil valve, next gradually open the outside air damper from its minimum ventilation air position while simultaneously gradually close the return air damper (ensure thorough mixing) and gradually open the exhaust air damper, and then gradually open the chilled water coil valve. A dry bulb temperature low limit sensor located in the mixed air (ensure thorough mixing) shall, on a fall in temperature, gradually open the preheat coil valve. An outdoor air dry bulb sensor disables the economizer cycle and maintains minimum ventilation air when the outside air dry bulb temperature exceeds the changeover point.

g) Supply Duct Static Pressure Mode: A supply duct static pressure sensor located two-thirds the distance from the fan of the length of the longest supply duct run shall, on a rise in static pressure, gradually reduce the speed of the electric motor variable speed drive and close the fan vortex damper. A high-limit duct static pressure sensor located at the fan discharge shall override the supply duct static pressure sensor to limit pressures to design values.

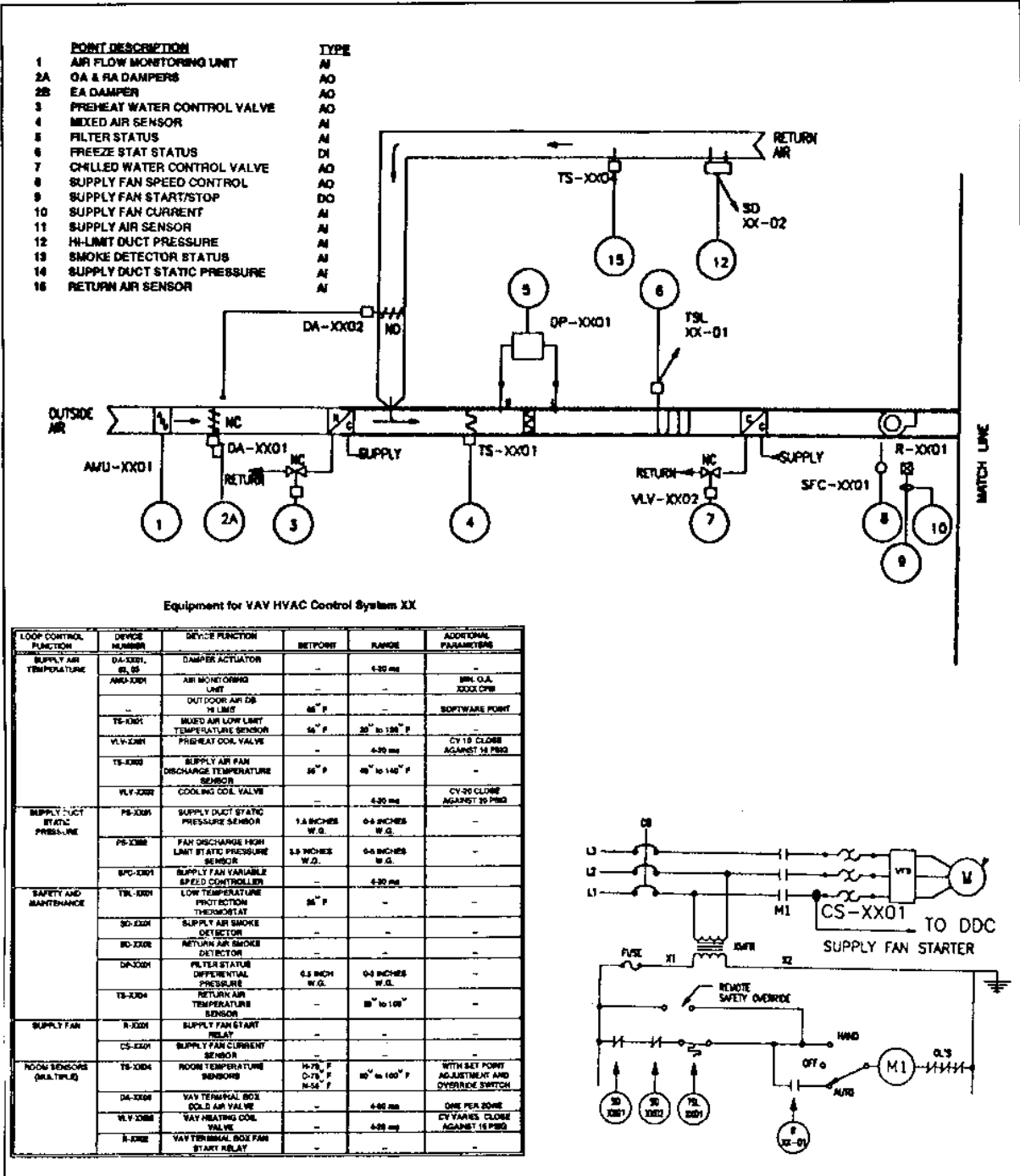

Figure 35  
Control System Schematic for VAV HVAC System XX

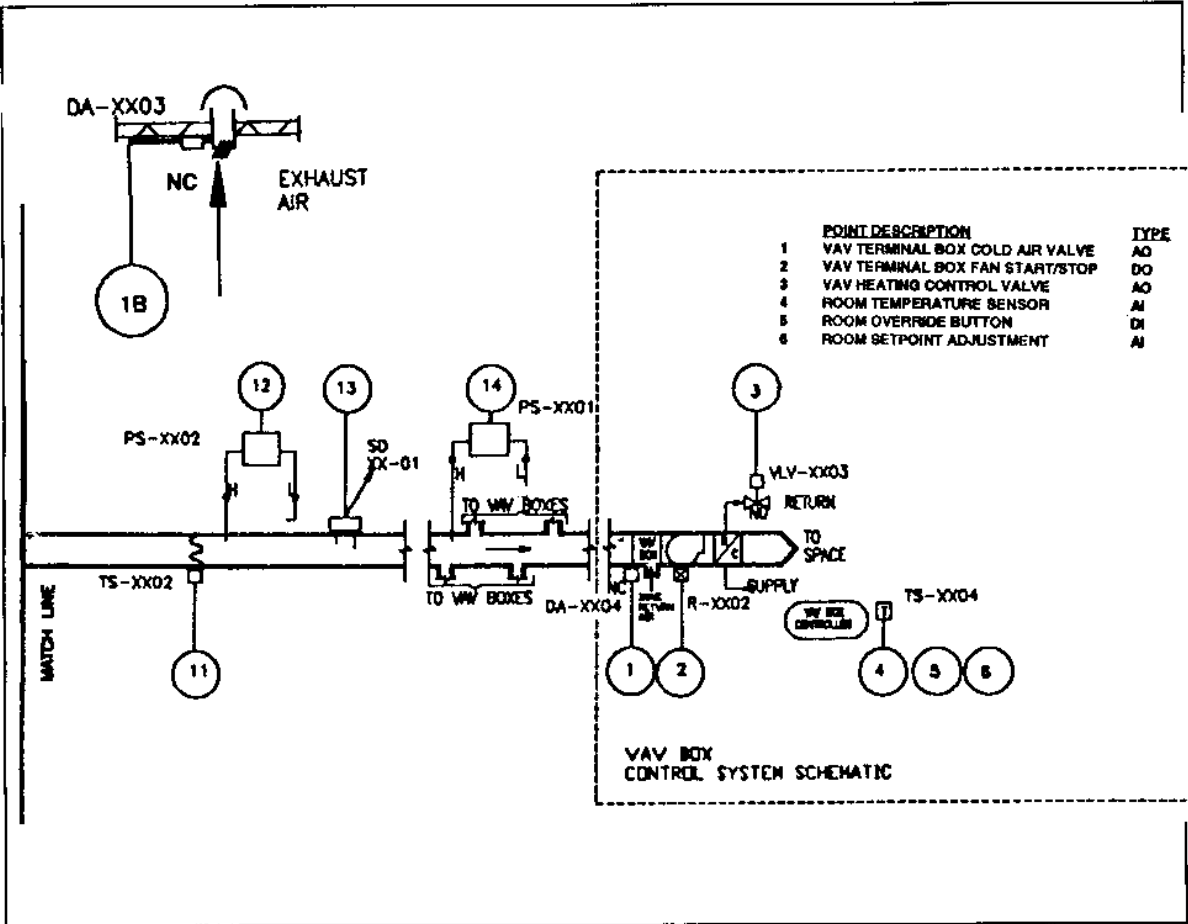

Figure 35 (Continued)  
Control System Schematic for VAV HVAC System XX

Table 17  
Equipment for VAV HVAC Control System XX

LOOP CONTROL FUNCTION	DEVICE NUMBER	DEVICE FUNCTION	SETPOINT	RANGE	ADDITIONAL PARAMETERS
SUPPLY AIR TEMPERATURE	DA-XX01, 02, 03	DAMPER ACTUATOR	--	4-20 ma	--
	AMU-XX01	AIR MONITORING UNIT	--	--	MIN. O.A. XXXX CFM
	--	OUTDOOR AIR DB HI LIMIT	65° F	--	SOFTWARE POINT
	TS-XX01	MIXED AIR LOW LIMIT TEMPERATURE SENSOR	55° F	30-130° F	--
	VLV-XX01	PREHEAT COIL VALVE	--	4-20 ma	CV-10 CLOSE AGAINST 16 PSIG
	TS-XX02	SUPPLY AIR FAN DISCHARGE TEMPERATURE SENSOR	55° F	40-140° F	--
	VLV-XX02	COOLING COIL VALVE	--	4-20 ma	CV-20 CLOSE AGAINST 20 PSIG
SUPPLY DUCT STATIC PRESSURE	PS-XX01	SUPPLY DUCT STATIC PRESSURE SENSOR	1.5 IN. W.G.	0-5 IN. W.G.	--
	PS-XX02	FAN DISCHARGE HIGH LIMIT STATIC PRESSURE SENSOR	3.5 IN. W.G.	0-5 IN. W.G.	--
	SFC-XX01	SUPPLY FAN VARIABLE SPEED CONTROLLER	--	4-20 ma	
SAFETY & MAINTENANCE	TSL-XX01	LOW TEMPERATURE PROTECTION THERMOSTAT	35° F	--	--



Table 17 (Continued)  
Equipment for VAV HVAC Control System XX

LOOP CONTROL FUNCTION	DEVICE NUMBER	DEVICE FUNCTION	SETPOINT	RANGE	ADDITIONAL PARAMETERS
SAFETY & MAINTENANCE (CONT'D)	SD-XX01	SUPPLY AIR SMOKE DETECTOR	--	--	--
	SD-XX02	RETURN AIR SMOKE DETECTOR	--	--	--
	DP-XX01	FILTER STATUS DIFFERENTIAL PRESSURE	0.5 IN. W.G.	0-2 IN. W.G.	--
	TS-XX04	RETURN AIR TEMPERATURE SENSOR	--	50-100° F	--
SUPPLY FAN	R-XX01	SUPPLY FAN START RELAY	--	--	--
	CS-XX01	SUPPLY FAN CURRENT SENSOR	--	--	--
ROOM SENSORS (MULTIPLE)	TS-XX04	ROOM TEMPERATURE SENSORS	H-70° F C-76° F N-55° F	50-100° F	WITH SETPOINT ADJUSTMENT & OVERRIDE SWITCH
	DA-XX04	VAV TERMINAL BOX COLD AIR VALVE	--	4-20 ma	ONE PER ZONE
	VLV-XX03	VAV HEATING COIL VALVE	--	4-20 ma	CV VARIES CLOSE AGAINST 16 PSIG
	R-XX02	VAV TERMINAL BOX FAN START RELAY	--	--	--

h) Room Control Mode: A room type dry bulb temperature sensor located in the most critical spot shall, on a rise in dry bulb temperature in the space, gradually open the VAV terminal box cold air valve.

## 8.6 Commissioning Procedures

8.6.1 Functional Performance Test. Participate in the functional performance test as described in ASHRAE Guideline 1.

Verify and document the performance of the control system as required by the Commissioning Plan prepared by the Commissioning Authority. Final positions of manual balancing dampers and valves shall be marked on the device. Permanently record, on system equipment schedule, the final setting of controller proportional, integral, and derivative constant settings in units and terminology specific to the controller. This will become part of the O&M manual.

8.6.2 Preparation for Acceptance Testing. Execute a detailed static and functional checkout procedure to ensure that systems are ready for functional performance testing.

8.6.3 System Static Checkout

8.6.3.1 Observation. Provide a detailed inspection to assure that all equipment is properly mounted, sensors are properly installed and connected, control devices are properly installed, and controllers and control devices are properly connected.

8.6.3.2 Calibration. Check, verify, and calibrate all sensors including those sensors that are "factory calibrated." Perform a two-point accuracy check of the calibration of each HVAC control system sensing element by comparing the HVAC controller readout to the actual value of the variable measured at the sensing element or airflow measurement station location. Use digital indicating test instruments, such as digital thermometers, motor-driven psychrometers, and tachometers. Test instruments shall be at least twice as accurate as the specified sensing element-to-controller readout accuracy. Calibration of test instruments shall be traceable to National Institute of Standards and Technology (NIST) standards. In the shutdown condition, calibration checks shall verify that the sensing element-to-controller readout accuracies at two points are within the specified product accuracy tolerances. If not, re-calibrate or replace the inaccurate device and repeat the calibration check.

a) Check insertion temperature and immersion temperature sensing element and transmitter-to-controller readout calibration accuracy at one physical location along the axis of the sensing element.

b) Check averaging temperature sensing element and transmitter-to-controller readout calibration accuracy every 2 feet along the axis of the sensing element in the proximity of the sensing element, for a maximum of 10 readings. Then average these readings.

c) Verify space type sensors by placing the test instrument as close as possible to the sensor to measure identical conditions. Maintain the test for a sufficient length to ensure achieving stable conditions.

#### 8.6.3.3 Operation

a) Each controller shall be configured for its specified service. Verify each sequence of operation for each HVAC system and subsystem. Verify that each controlled device responds to the proper controller, in the proper manner, and at the proper time. Verify the fail-safe position for each component of the system.

b) Set the time schedule of controllers in accordance with the sequence of operation and the established time schedule.

8.6.4 System Dynamic Checkout. Perform weather-dependent test procedures that cannot be performed by simulation in the appropriate climatic season. When simulation is used, verify the actual results in the appropriate season.

a) Use the controllers' manual-automatic switches as the means of manipulating control devices such as dampers and valves to check operation and to effect stable conditions, prior to making measurement checks.

b) Perform a controller tuning procedure, which shall consist of setting the initial proportional, integral, and derivative (PID) mode constants, controller setpoints, and logging the settings. Tuning shall be self-tuning operation by the controller unless manual tuning is necessary.

8.6.4.1 Controller Manual-Tuning Procedure. A controller manual tuning procedure is described in three steps using a constant temperature setpoint controller as an example.

a) Step 1. This step shall consist of the following:

(1) Index the controller manual-automatic switch to the automatic position, and set the integral and derivative mode constants to zero.

(2) Set the proportional mode constant to an initial setting of 8 percent. This corresponds to a 2.0 ma per degree F or a 1.5 psig per degree F proportional controller output change for a 100-degree F span. This causes the controller output signal to vary from zero output to full output for an input signal change representing an 8-degree F change.

(3) Controllers for other variables, such as relative humidity and static pressure, shall have their proportional mode constants set initially in a similar manner for an achievable output range proportional to the transmitter span.

b) Step 2. This step shall consist of the following:

(1) Set the controller temperature setpoint at any achievable temperature. Observe the controller output and transmitter input.

(2) If the transmitter input continuously oscillates above and below the setpoint without settling at a fixed value, or if such oscillation increases, the proportional mode constant is too small.

(3) If the proportional mode constant is too small, increase it in steps until the transmitter input indicates stable control at any temperature, if the controller output is not at either extreme of the output range.

(4) If the temperature control point slowly drifts toward or away from the controller setpoint, the proportional mode constant is too large. Decrease its setting in steps until oscillations occur as described in the preceding paragraphs, and then increase the setting until stable control occurs.

(5) Introduce a step change in controller setpoint. This should cause the controller to overshoot the setpoint slightly, with each subsequent overshoot peak value decreasing by a factor of two-thirds until stable control is achieved at, above, or below the setpoint.

(6) Increase the integral mode constant setting in small steps, and introduce setpoint changes until control point and controller setpoint coincide at stable control. This should happen consistently after a setpoint change within a short time, such as 5 to 10 minutes.

c) Step 3. This step shall consist of the following:

(1) Unless the HVAC process variable changes rapidly, the derivative mode constant setting can remain at zero. This is usually the case for most HVAC applications.

(2) If derivative control is needed, gradually increase the derivative mode constant.

(3) Introduce step changes in controller setpoint, and adjust the derivative mode constant setting until stable control is achieved.

d) Step 4. After the controller manual tuning procedure is complete, set the controller at the predetermined setpoint in the design drawings.

#### 8.6.5 Procedures for Single Zone Control System (Sample)

a) System Inspection. Observe the HVAC system in its shutdown condition. Check to see that power (and main air) is (are) available for the HVAC system control devices. Check to see that the outside air damper, relief air damper, heating coil valve, and cooling coil valve are closed, and that the return air damper is open. Check to see that the preheat coil valve is being controlled by the mixed air low limit controller.

b) Calibration Accuracy Check. Check with HVAC system in the shutdown condition. Take readings with a digital thermometer at each temperature sensing element location. Read each controller display, and log the thermometer and controller display readings. Check the calibration accuracy of the sensing element to controller readouts for outside air, return air, mixed air, and supply air temperatures.

c) Actuator Range Adjustments. Apply a signal to each actuator, by placing the controller manual-automatic switch in the manual position. Verify visually the proper operation of the actuators for dampers and valves. Vary the signal from 4 ma (or 3 psig) to 20 ma (or 15 psig), and verify that the actuators travel from zero stroke to full stroke within the signal range. Observe that sequenced and parallel operated actuators move from zero stroke to full stroke in the proper direction, and move the connected device in the proper direction from one extreme position to the other. Example: Normally closed actuators are closed at 4 ma (or 3 psig) and are open at 20 ma (or 15 psig). Log the signal levels that move the controlled device to its extreme positions.

#### d) Control System Startup

(1) With the fan ready to start, apply the optimized start mode command, and observe that the designated supply fan starts. Observe that the outside air and relief air dampers are closed, the return air damper is open, and the heating coil valve and preheat coil valve (cooling coil valve) are in the warm up (cool down) position. Change the command to occupied mode and observe that the outside air damper, return air

damper, relief air damper, heating coil valve, preheat coil valve, and chilled water valve are in control, by changing the controller output.

(2) Apply the minimum outside air mode signal. Observe that the outside air damper opens to the minimum position.

(3) Index the mixed air low limit temperature controller manual-automatic switch to the manual position. Perform the two-point calibration accuracy check of sensing element-to-controller readout. Index the mixed air low limit temperature controller manual-automatic switch to the automatic position. Change the controller output to open the preheat coil valve slightly. Perform the controller tuning procedure. Set the controller at the predetermined temperature setpoint. Apply the economizer mode input signal, and observe that the outside air, return air, and relief air dampers are under control. Index the supply air low limit temperature controller manual-automatic switch to the manual position. Perform the two-point calibration accuracy check of sensing element-to-controller readout. Index the supply air low limit temperature controller manual-automatic switch to the automatic position. Change the controller output to open the heating coil valve slightly. Perform the controller tuning procedure. Set the controller at the predetermined temperature setpoint. Index the room temperature controller manual-automatic switch to the manual position, and perform the two-point calibration accuracy check of sensing element-to-controller readout. Index the controller manual-automatic switch to the automatic position, and perform the controller tuning procedure. Set the controller at the temperature setpoint as shown.

(4) Apply an unoccupied mode signal, and observe that the HVAC system shuts down, and the control system assumes the specified shutdown conditions. Raise the night thermostat temperature setting and observe that the HVAC system starts. Lower the setting and observe that the HVAC system stops. Set the night thermostat at the predetermined setting.

(5) With the HVAC system running, simulate a filter differential pressure switch input signal at the device. Observe that the filter alarm is activated. Set the differential pressure switch at the predetermined setpoint.

(6) With the HVAC system running, simulate a low temperature condition at the freezestat. Observe HVAC system shutdown and that the low temperature alarm is activated. Set

the thermostat at the predetermined setpoint. Restart the HVAC system by manual reset, and observe that the alarm is deactivated.

(7) With the HVAC system running, simulate a smoke detector trip input signal at each detector, and observe and verify operation as described in the sequence of operation. Perform simulation without false-alarms any life safety systems. Observe that the HVAC system shuts down and the alarm is activated. Reset the detectors. Restart the HVAC system by manual reset, and observe that the alarm is deactivated.

#### 8.6.6 Procedures for Multizone Control System (Sample)

a) System Inspection. Observe the HVAC system in its shutdown condition. Check to see that power (and main air) is (are) available for the HVAC system control devices. Check to see that the outside air damper, relief air damper, heating coil valve, and cooling coil valve are closed, and that the return air damper is open. Check to see that the preheat coil valve is being controlled by the mixed air low limit controller.

b) Calibration Accuracy Check. Check with the HVAC system in the shutdown condition: take readings with a digital thermometer at each temperature sensing element location; read each controller display, and log the thermometer and controller display readings; and check the calibration accuracy of the sensing element to controller readouts for outside air, return air, mixed air, cold deck air, and hot deck air temperatures.

c) Actuator Range Adjustments. Apply a signal to each actuator by placing the controller manual-automatic switch in the manual position. Verify visually the proper operation of the actuators for dampers and valves. Vary the signal from 4 ma (or 3 psig) to 20 ma (or 15 psig), and verify that the actuators travel from zero stroke to full stroke within the signal range. Observe that sequenced and parallel operated actuators move from zero stroke to full stroke in the proper direction, and move the connected device in the proper direction from one extreme position to the other. Example: Normally closed actuators are closed at 4 ma (or 3 psig) and are open at 20 ma (or 15 psig). Log the signal levels that move the controlled device to its extreme positions.

#### d) Control System Startup

(1) With the fan ready to start, apply the optimized start mode command, and observe that the designated supply fan starts. Observe that outside air and relief air

dampers are closed, the return air damper is open, and the heating coil valve and preheat coil valve (cooling coil valve) are in the warm-up (cool down) position. Change the command to occupied mode and observe that the outside air damper, return air damper, relief air damper, heating coil valve, preheat coil valve, and chilled water valve are in control, by changing the controller output.

(2) Apply the minimum outside air mode signal. Observe that the outside air damper opens to the minimum position.

(3) Index the cold deck coil temperature controller manual-automatic switch to the manual position, and perform the two-point calibration accuracy check of sensing element-to-controller readout. Index the controller manual-automatic switch to the automatic position, and perform the controller tuning procedure. Set the controller at the temperature setpoint as shown. Index the mixed air low limit temperature controller manual-automatic switch to the manual position. Change the controller output to open the preheat coil valve slightly. Perform the two-point calibration accuracy check of sensing element-to-controller readout for outside air, return air, and mixed air temperatures. Index the mixed air low limit temperature controller manual-automatic switch to the automatic position. Apply the economizer mode input signal, and observe that the outside air, return air, and relief air dampers are under control. Perform the controller tuning procedure. Set the controller at the predetermined temperature setpoint.

(4) Apply an unoccupied mode signal, and observe that the HVAC system shuts down, and the control system assumes the specified shutdown conditions. Raise the night thermostat temperature setting and observe that the HVAC system starts. Lower the setting and observe that the HVAC system stops. Set the night thermostat at the predetermined setting.

(5) With the HVAC system running, simulate a filter differential pressure switch input signal at the device. Observe that the filter alarm is activated. Set the differential pressure switch at the predetermined setpoint.

(6) With the HVAC system running, simulate a low temperature condition at the freezestat. Observe HVAC system shutdown and that the low temperature alarm is activated. Set the thermostat at the predetermined setpoint. Restart the HVAC system by manual reset, and observe that the alarm is deactivated.



(7) With the HVAC system running, simulate a smoke detector trip input signal at each detector, and observe and verify operation as described in the sequence of operation. Perform simulation without false-alarmed any life safety systems. Observe that the HVAC system shuts down and the alarm is activated. Reset the detectors. Restart the HVAC system by manual reset, and observe that the alarm is deactivated.

(8) Raise the temperature setpoint of each room thermostat and observe that the zone damper closes to the cold deck and opens to the hot deck. Calibrate the room thermostat of each zone. Set each room thermostat at its predetermined setpoint.

#### 8.6.7 Variable Air Volume Control System (Sample)

a) System Inspection. Observe the HVAC system in its shutdown condition. Check to see that power (and main air) is (are) available for the HVAC system control devices. Check to see that the outside air, relief air dampers, heating coil valve, and cooling coil valve are closed, and the return air damper is open. Check to see that the preheat coil valve is being controlled by the mixed air low limit controller.

b) Calibration Accuracy Check With HVAC System in Shutdown Condition. Take readings with a digital thermometer at each temperature sensing element location. Read each controller display, and log the thermometer and controller display readings. Check the calibration accuracy of the sensing element-to-controller readout for outside air, return air, mixed air, and cooling coil discharge air temperatures.

c) Actuator Range Adjustments. Apply a signal to each actuator by placing the controller manual-automatic switch in the manual position. Verify visually the proper operation of the actuators for dampers and valves. Vary the signal from 4 ma (or 3 psig) to 20 ma (or 15 psig), and verify that the actuators travel from zero stroke to full stroke within the signal range. Observe that sequenced and parallel operated actuators move from zero stroke to full stroke in the proper direction, and move the connected device in the proper direction from one extreme position to the other. Example: Normally closed actuators are closed at 4 ma (or 3 psig) and are open at 20 ma (or 15 psig). Log the signal levels that move the controlled device to its extreme positions.

d) Control System Startup

(1) With the fan ready to start, apply the optimized start mode command, and observe that the designated supply fan starts. Observe that the outside air damper and relief air damper are closed, the return air damper is open, and the heating coil valve and preheat coil valve (cooling coil valve) are in the warm-up (cool down) position. Change the command to occupied mode and observe that the outside air damper, return air damper, relief air damper, heating coil valve, preheat coil valve, and chilled water valve are in control, by changing the controller output.

(2) Apply the minimum outside air mode signal. Observe that the outside air damper opens to its minimum position.

(3) With the supply fan running, simulate a high static pressure input signal at the device by pressure input to the sensing device. Observe HVAC system shutdown and that the high pressure alarm is activated. Restart the HVAC system by manual reset, and observe that the high static pressure alarm is deactivated.

(4) Index the supply fan static pressure controller manual-automatic switch to the manual position and perform a two-point accuracy check of sensing element-to-controller readout. Place the controller in the local setpoint mode. Index the controller manual-automatic switch to the automatic position, and perform the controller tuning procedure. Set the controller at the specified static pressure setpoint, and log the mode constant setpoints.

(5) Index the supply air temperature controller manual-automatic switch to the manual position, and perform the two-point calibration accuracy check of sensing element-to-controller readout. Index the controller manual-automatic switch to the automatic position, and perform the controller tuning procedure. Set the controller at the temperature setpoint as shown. Index the mixed air low limit temperature controller manual-automatic switch to the manual position. Change the controller output to open the preheat coil valve slightly. Perform the two-point calibration accuracy check of sensing element-to-controller readout for outside air, return air, and mixed air temperatures. Index the mixed air low limit temperature controller manual-automatic switch to the automatic position. Apply the economizer mode input signal, and observe that the outside air, return air, and relief air dampers are under control. Perform the controller tuning procedure. Set the controller at the predetermined temperature setpoint.

(6) Apply an unoccupied mode signal, and observe that the HVAC system and fan powered VAV terminal units shut down, and the control system assumes the specified shutdown conditions. Raise the night thermostat temperature setting and observe that the VAV terminal units start with the terminal unit heating valve open. Lower the setting and observe that the VAV terminal units stop. Set the night thermostat(s) at the predetermined setting.

(7) With the HVAC system running, simulate a filter differential pressure switch input signal at the device. Observe that the filter alarm is activated. Set the differential pressure switch at the predetermined setpoint.

(8) With the HVAC system running, simulate a low temperature condition at the freezestat. Observe HVAC system shutdown and that the low temperature alarm is activated. Set the thermostat at the predetermined setpoint. Restart the HVAC system by manual reset, and observe that the alarm is deactivated.

(9) With the HVAC system running, simulate a smoke detector trip input signal at each detector, and observe and verify operation as described in the sequence of operation. Perform simulation without false-alarmed any life safety systems. Observe that the HVAC system shuts down and the alarm is activated. Reset the detectors. Restart the HVAC system by manual reset, and observe that the alarm is deactivated.

(10) Set each pressure dependent VAV terminal unit to its minimum design airflow with a mechanical stop for the cold air damper. Set heating and cooling room temperature setpoints. Observe and verify the actions of the controller, the operation of the damper, and the operation of heating coil valves. Verify that space temperature is maintained.

## Section 9: EQUIPMENT LOCATION

9.1 General. Sometimes a building designer will seek clever ways to hide mechanical equipment rather than integrating it into the building in a way that will best serve the Navy over the life of the building. Although information and suggestions on equipment locations are found throughout this handbook, it was deemed appropriate to repeat some of this pertinent data within this section.

9.2 Specific Considerations

9.2.1 Noise. Will the noise from the equipment affect the use and occupancy of the building? Consider the following:

a) Certain types of HVAC equipment will emit a lot of noise. Centrifugal chillers are one type of noise emitting equipment. Install chillers in a sub-room and enclose this room with masonry walls so that there is enough mass to attenuate the radiated noise. The reason for a separate room is so that the operators will not have to wear earmuffs all day to meet OSHA and Navy noise exposure criteria. They can stay out of the chiller room most of the time.

b) Will objectionable levels of noise leak out and bother other occupants of the building or neighborhood? A classic example of this is a noisy cooling tower that runs all night long and keeps the nearby housing residents awake. A time clock on the mechanical system can sometimes help this problem. Another example would be a noisy air handler located above a hung ceiling that radiates sound downward into an occupied space (perhaps the base commander's office).

9.2.2 Access for Operations and Maintenance

a) Is it a major building demolition effort to repair or replace HVAC equipment?

b) Is it a major effort for the rigger to move equipment out to the street for repair?

c) Design systems for ease of maintenance. Is it easy for the HVAC mechanic to get to the equipment? Must the HVAC mechanic crawl, set up ladders, use a flashlight, remove a louver, remove access panels, walk on an unprotected roof, or use a rope to pull up his tools? Can the mechanic thread in replacement piping, pull the filters, punch the tubes, acid clean

the heat exchangers, and replace the fan bearings? Consider providing space for access, and lighting for maintenance, access doors, walkways, and catwalks.

9.2.3 Blocked Access. Is a critical access blocked, or is an annoying delay created when doing needed work on HVAC? Does the oil delivery truck block the main entrance? Can the fire pumper truck get to the Siamese connection? Must salt bags for the water softener be trucked through the lobby or a main corridor? Design for ease of maintenance.

9.2.4 Emission of Odors. A common source of odor is a kitchen range hood from a side wall outlet. Consider the geometry of the site and adjacent buildings, both existing and proposed, for planning intakes and exhaust points. Review 10 year base map plan for future building locations. Sometimes the kitchen exhaust can be run up a shaft and exhausted above the roof. Another helpful way to minimize the problem is to use a washdown kitchen hood to reduce the odor.

Another source of odor is the pathological waste incinerator at a hospital. Even the newer types of incinerators with after burners create problems when burning tissue. One solution is to transport the pathological waste to a remote incinerator site for burning.

Use this philosophy when planning laboratory exhaust and outside air building intakes. Try point source containment or neutralization of noxious exhausts at the hoods or exhaust points or put stacks on the exhaust ducts.

9.2.5 Cooling Tower Vibration. Use care when locating cooling towers on roofs of light steel frame buildings to avoid harmonic vibration of equipment. Vibration isolators are not always a solution to this problem. Analytical tools are available to help solve vibration problems. A vibration engineer can be retained to study vibration problems and provide solutions. This kind of equipment could be installed on the basement floor slab or located elsewhere. Another possible solution is to change the equipment vibration frequency by providing a concrete pad under the machine to eliminate its harmonics.

Section 10: FUNDAMENTAL DRAWING DETAILS

10.1 General. Refer to Section 4 and the A-E Handbook issued by the local NAVFACENGCOM EFD or EFA for an overview of the information required on the drawings.

10.2 Specifics

10.2.1 System Diagrams and Schematics. See Figures 36 and 37 for examples of system diagrams and schematics.

10.2.2 Equipment Schedules. See Tables 18 through 20 for examples of equipment schedules.

10.2.3 Riser Diagrams. See Figures 38 and 39 for examples of riser diagrams.

10.2.4 Duct Pressure Classifications. See Figure 40 for an example showing duct pressure classifications.

10.2.5 Symbols and Abbreviations. Consider the following when using symbols and abbreviations:

a) Use symbols and abbreviations found in ASHRAE Handbook, Fundamentals.

b) List only those symbols and abbreviations that are used in the design.

c) Coordinate the various abbreviation lists to ensure that the abbreviations are not duplicated.

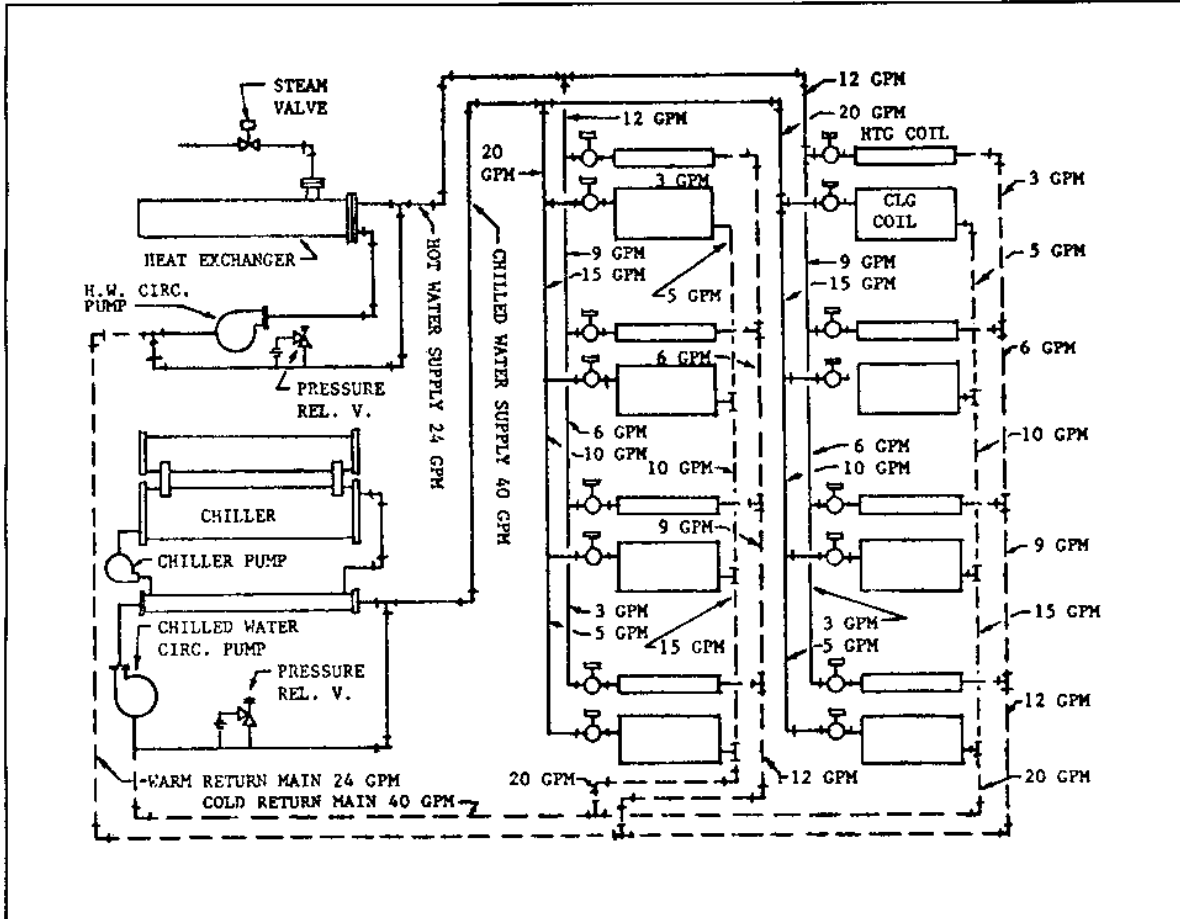

Figure 36  
Schematic Hot Water and Chilled Water Balancing Diagram

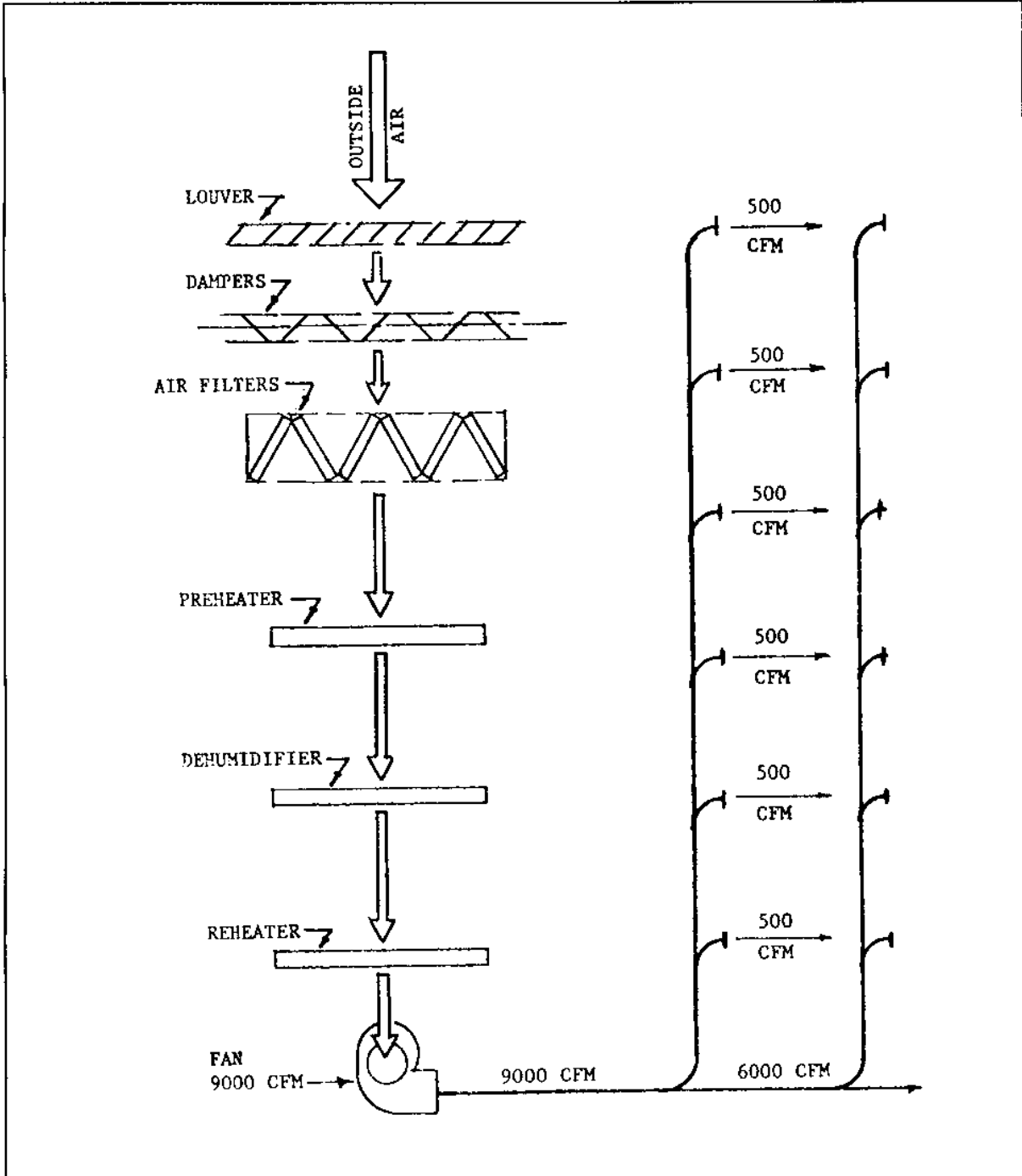

Figure 37  
Schematic Airflow Balancing Diagram



Table 18  
Typical Utility Fan Schedule

NO. ON		UTILITY FAN								REMARKS
DWGS	TYPE	DRIVE	FAN CFM	RPM	SP IN.	MOTOR HP PH V				
UFY	SISW	BELT	2920	1750	3.30	5	3	240	NON-SPARKING	

Table 19  
Sound Data Schedule

EQUIPMENT	MAXIMUM SOUND POWER LEVEL (dB)								
	OCTAVE BAND LEVEL CENTER FREQUENCY (Hz)								
	63	125	250	500	1000	2000	4000	8000	
AIR COMPRESSOR	90	89	92	93	92	92	90	81	
FAN	55	50	48	47	48	46	42	37	
BOILER	75	72	72	75	76	63	55	50	
FAN COILS	68	66	62	58	52	47	43	37	
PUMPS	85	80	82	82	80	77	74	72	

Table 20  
Cooling Coil Schedule

NO. ON	CFM	SIZE		AIR PRESSURE DROP WATER	ENTER- ING AIR		LEAVING AIR		WATER PRESS. DROP		WATER TEMP.	
		W	H		DEG. F DB	DEG. F WB	DEG. F DB	DEG. F WB	GPM FT	IN	OUT	
CC-1	7200	42	33	0.36	90	70	75	65	35	1.30	55	61.7

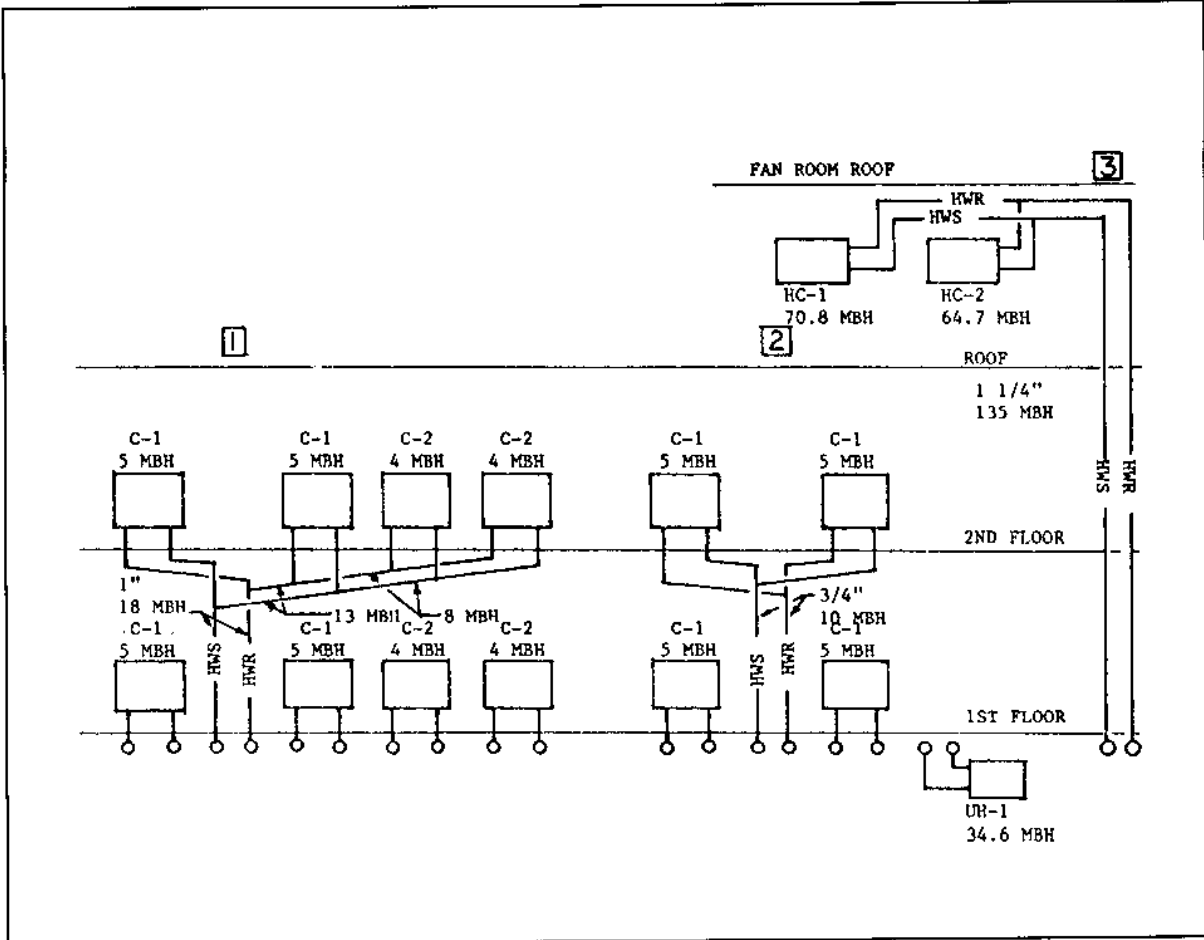

Figure 38  
Hot Water Riser Diagram

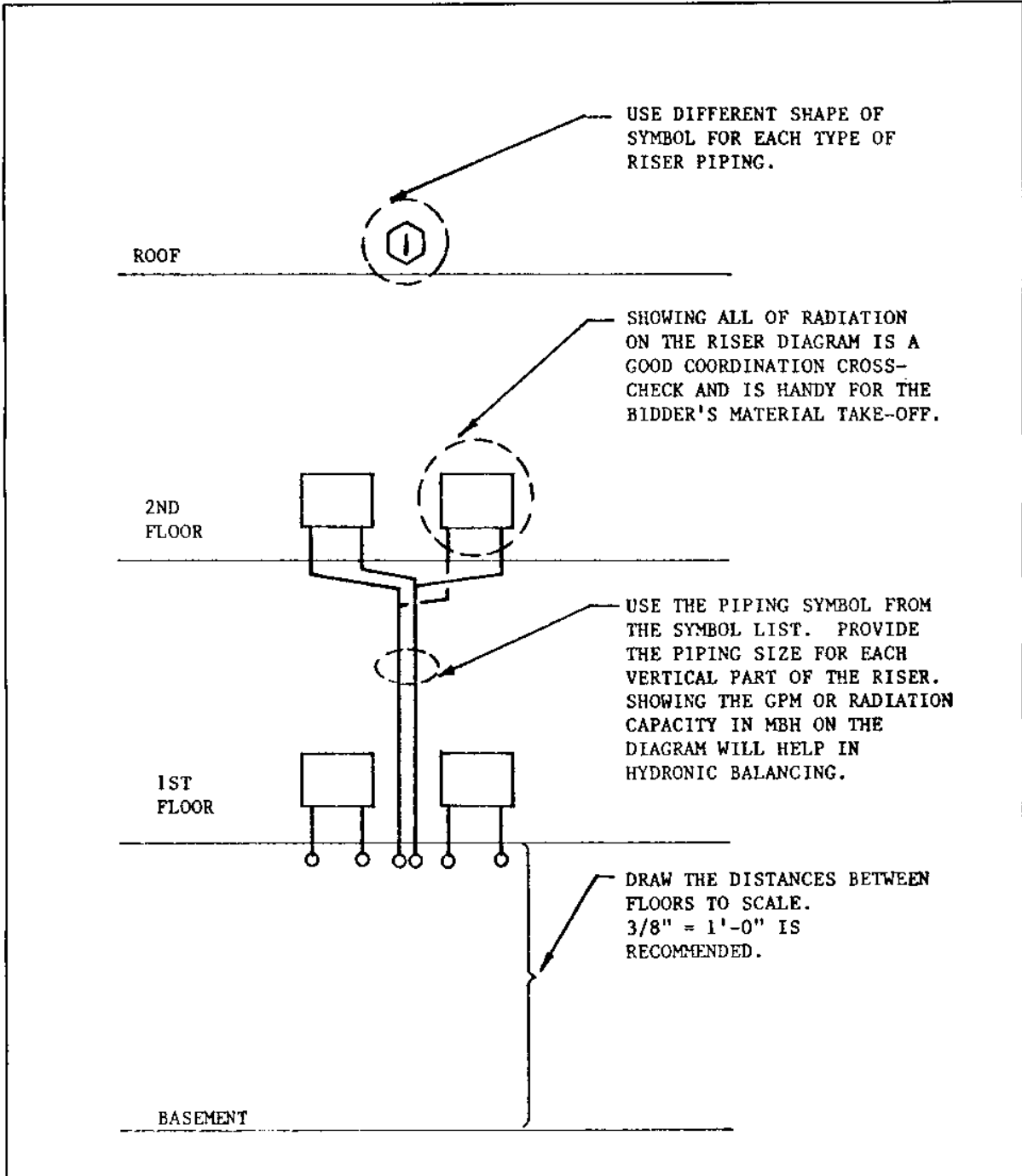

Figure 39  
Notes on Drawing Riser Diagram

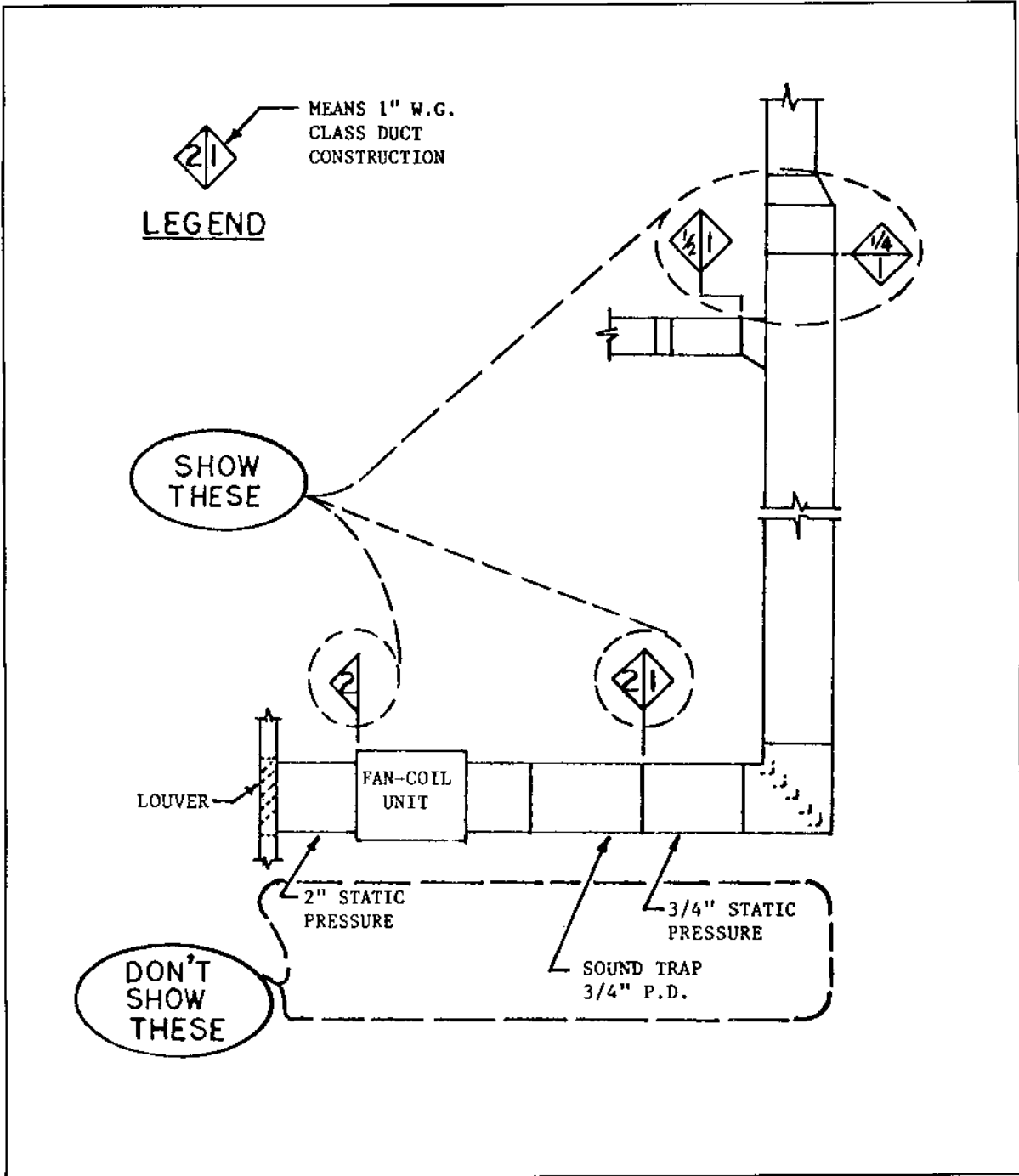

Figure 40  
Designating Duct Pressure Classes

## Section 11: RULES OF THUMB GUIDANCE

11.1 General. The following information provides guidance that could be used in planning to estimate utility requirements and to assess the adequacy of equipment sizing during design reviews. Note that it is preferable to do a quick block load calculation instead of using these rules of thumb.

11.2 Air Conditioning Capacity. See Table 21.

11.3 Heating Capacity. 35 to 40 Btu per square foot for mild climate region (less than 4,000 degree days), no fresh air load.

11.4 Moisture Loads. See Table 22.

11.5 Chilled Water Circulation. 2.5 to 3.0 gallons per minute per ton.

11.6 Hot Water

Gallon per minute =  $\frac{\text{Btu/h}}{10,000}$   
(20 degree drop)

Gallon per minute =  $\frac{\text{Btu/h}}{500 \times \text{TD (temperature drop)}}$

11.7 Condenser Water. Required thermal capacity of cooling water = 15,000 Btu/h per ton, or  
= 3 gpm per ton

11.8 Steam. 1 pound of steam per 1,000 Btu.

11.9 Condensate. 120 gallons per 1,000 pounds steam.

Table 21  
Air Conditioning Load Estimating Factors

APPLICATIONS	AIR CONDITIONING FLOOR AREA SQ. FT./TON (EXCEPT WHERE NOTED)
ADMINISTRATION BUILDING	450-600
AUDITORIUMS, THEATERS	0.004 TO 0.08 TONS/SEAT
BOWLING ALLEYS	0.8 TO 1.4 TONS/ALLEY
COMPUTER ROOMS	50 TO 150
DINING ROOMS	175 TO 450
DISPENSARIES	450 TO 550
ENLISTED MEN'S AND OFFICER'S CLUBS	275 TO 375
HOSPITAL PATIENT ROOMS	450 TO 550
MULTIPLE FAMILY HOUSING UNITS	900 TO 1275
RECREATION ROOMS	375 TO 450
RELIGIOUS FACILITIES	0.02 TO 0.03 TONS/SEATS
HOPS (PRECISION EQUIPMENT)	450 TO 550
TRAINING FACILITIES	400 TO 500
BACHELOR QUARTERS	725 TO 900

Table 22  
Typical Load Breakdown of Dehumidified Warehouse

MOISTURE SOURCE	MOISTURE LOAD LB. WATER/DAY	PERCENT OF TOTAL MOISTURE LOAD (FLOOR W/MEMBRANE)
FLOOR (WITHOUT A MEMBRANE)	180 TO 420	----
FLOOR (WITH A MEMBRANE)	120 TO 240	19
WALL TRANSMISSION	50 TO 100	8
ROOF TRANSMISSION	20 TO 60	3 TO 5
BREATHING	40 TO 55	3 TO 4
WALL INFILTRATION	150 TO 300	24
OPEN DOOR	200 TO 400	32
STORES (5% ANNUAL TURNOVER)	50 TO 130	8 TO 11

Section 12: FIRE PROTECTION AND SMOKE CONTROL

12.1 General. Comply with MIL-HDBK-1008B. This is one phase of the HVAC design effort when the designer should consult early and often with the architectural designer to obtain locations and ratings of firewalls, ceiling assemblies, exit pathways, smoke barrier partitions, shafts, stairwells, etc. It is also the time to establish which codes and which provisions of these codes will apply.

12.2 System Design. Comply with NFPA 90A and NFGS-15971 or NFGS-15972. Some general references that should be followed are as follows:

a) Ceiling plenums of the HVAC system shall conform to NFPA 90A.

b) Follow applicable NFPA codes for exit corridors. Do not use the corridor for air movement for an HVAC system.

c) Put fire dampers in firewall and rated ceiling openings, and smoke dampers at smoke barriers.

d) Put vertical ducts in rated shafts.

e) Systems 15,000 cfm and over shall have automatic fan shutdown activated by smoke detectors in the supply duct downstream of the filter and in the return duct system at each floor.

f) Systems of 15,000 cfm and over shall also have supply air and return air smoke dampers to isolate air handling equipment from the occupied space.

g) Fire dampers and smoke detectors need access doors in the ducts.

h) Smoke detectors are required in the supply air of HVAC systems from 2,000 to 15,000 cfm for child care centers, schools, brigs, hospitals, and others buildings where people congregate. Do not use firestats.

I) Note that the above requirements will change if the designer provides an engineered smoke control system.

j) For engineered smoke control systems, refer to Appendix B.

12.3 Engineered Smoke Control System. If the designer elects to consider an engineered smoke control system in lieu of following the basic provisions of NFPA 90A, then note the following:

a) It may not always serve the best interest of the Navy to install engineered smoke control systems in Navy buildings.

b) For information on engineered smoke control systems, refer to Appendix B.



APPENDIX A  
ENERGY CONSERVATION METHODSA-1.00 Energy Conservation by Optimization of Controls

A-1.01 Intermittent Occupancy Controls. Classrooms, conference rooms, cafeterias, and other areas with intermittent occupancy shall have occupied/unoccupied switches. These switches shall function to eliminate conditioning of spaces when the room is not being used.

A-1.02 Space Temperature Requirements for Interior Zones. Refer to MIL-HDBK-1190.

A-1.03 Perimeter Radiation Heating Systems Control. Perimeter heating system controls shall have daytime, and a lower nighttime, reset schedule. During occupied periods, excessive internal heat gains are produced by internal loads (for example people, lighting, and equipment). Perimeter radiation systems shall be designed for the absence of these loads while maintaining night setback temperature. When used with VAV systems without reheat coils, provide radiation capacity to heat ventilation air to room setpoint during occupied cycle. Do not oversize but do add a 10 percent allowance for morning warm-up after night setback.

A-1.04 Energy Efficient Control System

A-1.04.1 Night Setback. A night setback allows the heating system to cycle automatically at the minimum allowable space temperature. These systems are generally provided with time clocks. Use electronic programmable time clocks or DDC programs for night, weekend, and holiday temperature setback (or cutoff) in the winter and set up (or cutoff) in the summer to reduce heating and cooling loads respectively. Normally, when unoccupied, air conditioning for personnel comfort will be cut off and heating will be reduced by approximately 15 degrees F.

A.1.04.2 Occupied/Unoccupied Hot Water Reset Schedule. An occupied/unoccupied hot water reset schedule is a dual setting system which allows for use of internal heat from equipment, lights, and people as part of the heat supply during occupied hours. See Figure A-1. During occupied hours, the setting is lower than during unoccupied hours, when there is not as much internal heat gain.

A-1.04.3 Direct Digital Control (DDC). DDC control systems provide the functions of a typical building automatic control system. Systems can also provide an effective operator interface

APPENDIX A (Continued)

to allow diagnostics of HVAC system operation from a remote location. Use care to provide and locate accurate sensors required by NFGS-15972.

There are many advantages of using DDC systems that make them preferred over conventional pneumatic, electric, or electronic systems. These include lower first cost, systems with fewer components, lower failure rate, greater accuracy of control, higher reliability, and lower maintenance cost. DDC systems may also incorporate remote monitoring and self-tuning to simplify operation and maintenance.

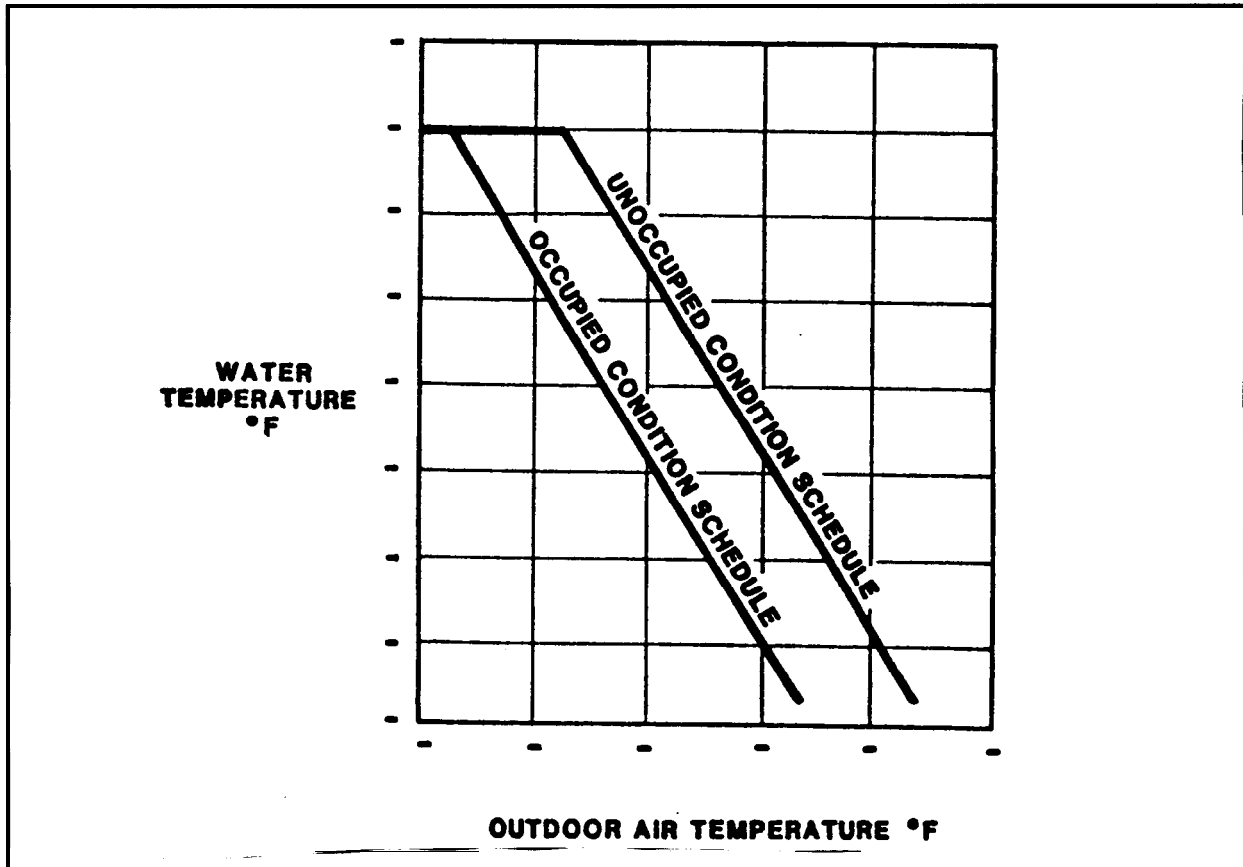

Figure A-1  
Occupied/Unoccupied Hot Water Reset Schedule

## APPENDIX A (Continued)

NFGS-15972 was prepared to take advantage of the many desirable features of a DDC system while minimizing anticipated problems by specifying appropriate hardware and software and by requiring adequate training for activity personnel. DDC systems should be specified for new projects and major renovations where operators and maintenance personnel are DDC qualified or are willing to accept DDC and receive proper training. Where these conditions are not met, use NFGS-15971 and provide pneumatic, analog electronic, or electric control systems.

DDC systems may be selected for repair or renovation of existing control systems to save energy and take advantage of the other features of DDC systems. Where existing pneumatic or electric valves and other actuators are proper and functional, they may work with the replacement DDC system with the appropriate interface.

EMCS is an outmoded concept and should be discouraged and avoided. EMCS added a computer based system to monitor existing pneumatic and analog electronic control systems and provided some energy saving strategies. Success of the EMCS depended on proper operation of the existing control system. When the existing control system failed, EMCS failed. If energy monitoring features are desired, a DDC system should be specified. If an operating EMCS is to be expanded and a DDC system will not be installed, refer to the Army Corps of Engineers, Architectural and Engineering Instructions, Design Criteria, Chapter 11, "Energy Conservation Criteria," and guide specification CEGS-15950, Heating, Ventilating, and Air Conditioning (HVAC) Control Systems for selection and application.

A-1.04.4 Thermostat Setpoints. Selective thermostat setpoints provide a temperature range in which no mechanical heating or air conditioning takes place. See Figure A-2. Deadband thermostats should not be used. Rather thermostats with separate control and setpoint for heating and cooling or DDC with separate control loops should be used. Strategies should control heating and cooling within one degree F of the respective setpoints.

A-2.00 Energy Conservation with Systems

## APPENDIX A (Continued)

NFGS-15972 was prepared to take advantage of the many desirable features of a DDC system while minimizing anticipated problems by specifying appropriate hardware and software and by requiring adequate training for activity personnel. DDC systems should be specified for new projects and major renovations where operators and maintenance personnel are DDC qualified or are willing to accept DDC and receive proper training. Where these conditions are not met, use NFGS-15971 and provide pneumatic, analog electronic, or electric control systems.

DDC systems may be selected for repair or renovation of existing control systems to save energy and take advantage of the other features of DDC systems. Where existing pneumatic or electric valves and other actuators are proper and functional, they may work with the replacement DDC system with the appropriate interface.

EMCS is an outmoded concept and should be discouraged and avoided. EMCS added a computer based system to monitor existing pneumatic and analog electronic control systems and provided some energy saving strategies. Success of the EMCS depended on proper operation of the existing control system. When the existing control system failed, EMCS failed. If energy monitoring features are desired, a DDC system should be specified. If an operating EMCS is to be expanded and a DDC system will not be installed, refer to the Army Corps of Engineers, Architectural and Engineering Instructions, Design Criteria, Chapter 11, "Energy Conservation Criteria," and guide specification CEGS-15950, Heating, Ventilating, and Air Conditioning (HVAC) Control Systems for selection and application.

A-1.04.4 Thermostat Setpoints. Selective thermostat setpoints provide a temperature range in which no mechanical heating or air conditioning takes place. See Figure A-2. Deadband thermostats should not be used. Rather thermostats with separate control and setpoint for heating and cooling or DDC with separate control loops should be used. Strategies should control heating and cooling within one degree F of the respective setpoints.

A-2.00 Energy Conservation with Systems

## APPENDIX A (Continued)

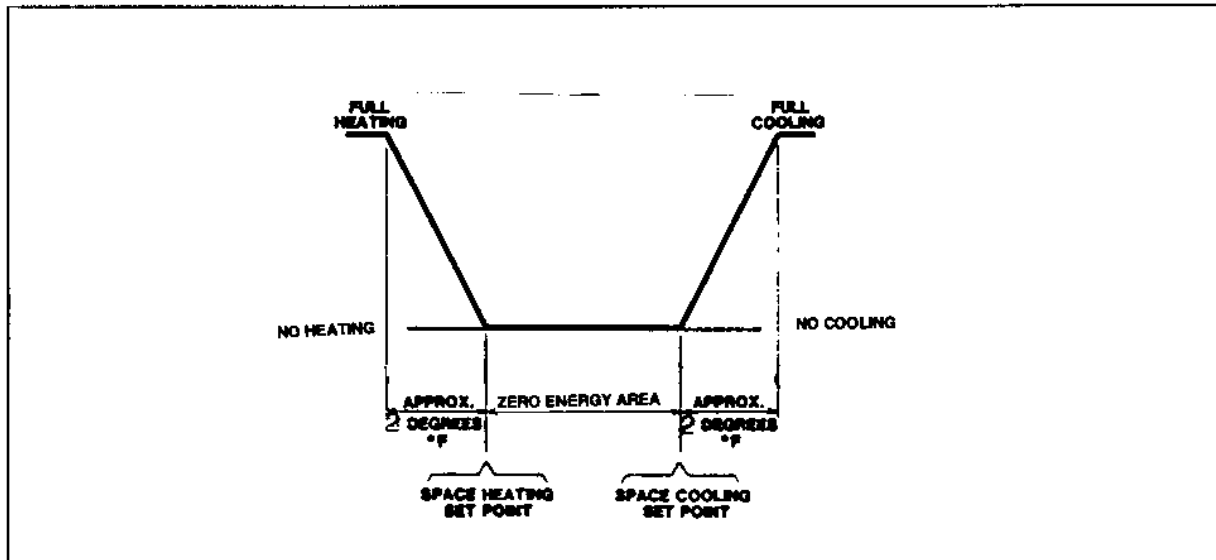

Figure A-2  
Thermostat Setpoints Diagram

A-2.01 Energy Efficient Systems. Design factors such as reliability can have priority over energy efficiency. An energy saving feature that is unstable or not maintained may fail and actually consume more energy than a simpler stable HVAC system. Select the least complicated energy efficient system for the application. Energy efficient devices shall be specified when possible if they are life cycle cost effective.

A-2.02 Economizer Cycle Systems. Contact the individual NAVFACENGCOCM EFD or EFA for exact guidance on the use of economizer cycles. In the absence of immediate guidance, systems larger than 10 tons shall be designed to use maximum outside air for cooling whenever the outdoor dry bulb temperature is lower than 60 degrees F more than 3000 hours per year. Operation shall be limited by an outdoor air dry bulb sensor. Do not use economizer cycle systems in humid climates.

A-2.03 Multiple Parallel Equipment Systems. Multiple parallel equipment systems, such as boilers, chillers, cooling towers, heat exchangers, air handlers, etc., provide superior operating efficiency, added reliability, and the operating capacity required at design conditions. Use multiple equipment systems when energy savings will offset higher first costs.

## APPENDIX A (Continued)

A-2.04 Direct Exhaust Systems. Direct exhaust systems may reduce the cooling load in a space requiring high ventilation rates to remove high heat loads of a source. Evaluate the energy required for the extra makeup air.

A-2.05 Heat Recovery Systems (Cascading Energies). Consider the following economic factors when evaluating heat recovery systems:

- a) Higher first costs,
- b) Higher maintenance costs,
- c) Additional building space requirements, and
- d) Added complication to HVAC equipment.

A-3.00 Exhaust Air Heat Recovery. With the air exhaust heat recovery system in the heating mode, heat from exhaust air is recovered and used to preheat the outdoor air supply, domestic hot water, boiler combustion air, and boiler makeup water. In the cooling mode, exhaust air is used to pre-cool outdoor air. In addition to the economic factors cited above, system pressure is increased. The five methods available for exhaust air heat recovery air are as follows:

- a) Rotary air wheel method,
- b) Static heat exchanger method,
- c) Heat pipe method,
- d) Runaround system/closed loop method, and
- e) Runaround system/open loop method.

The rotary air wheel, static heat exchanger, and heat pipe methods require supply and exhaust ducts to be adjacent ducts. Therefore, duct design should ensure that the outside air and exhaust air louvers are adequately separated to prevent cross contamination. Do not use rotary air wheel for industrial ventilating systems because of contamination carryover. For more information, refer to ASHRAE Equipment Handbook, the chapter entitled "Air-to-Air Energy Recovery Equipment."

## APPENDIX A (Continued)

A-3.01 Rotary Air Wheel. With the rotary air wheel, heat transfer takes place as the finned wheel rotates between the exhaust and supply duct. See Figure A-3. There are two types of rotary air wheels - one transfers only sensible heat, the other transfers both sensible and latent heat. The wheel is 70 percent effective for an equal supply and exhaust mass flow rates, but a certain amount of unavoidable leakage will reduce this effectiveness. Closely investigate cross contamination effects on the application, especially when the exhaust air is from a process source. Give this system full consideration in air conditioning and ventilating systems where exhaust air is 4,000 cfm or greater.

A-3.02 Plate Heat Exchanger. With the plate heat exchanger method heat transfers across alternate passages carrying exhaust and supply air in a counterflow or crossflow pattern. See Figure A-4 and Figure A-5.

Plate heat exchangers are 40 to 80 percent efficient in recovering heat, depending on the specific system design, temperature differences, and flow rates. Crossflow methods are usually more convenient, but counterflow methods are more efficient. With the plate exchanger method, only sensible heat is transferred. Plate heat exchanger is a static device having no moving parts, allowing for only a minimal chance of cross contamination. It is a relatively simple method of heat recovery.

A-3.03 Heat Pipe Method. The heat pipe method involves a self-contained, closed system which transfers sensible heat. This method consists of bundles of finned copper tubes, similar to cooling coils, sealed at each end and filled with a wick and working fluid. The working fluid may be water, refrigerant, or methanol.

For the most efficient system, the exhaust and supply air shall be counterflow. Performance also is improved by sloping the heat pipe so the warm side is lower than the cool side. See Figure A-6. For more information refer to ASHRAE Equipment Handbook, the chapter entitled "Air-to-Air Energy Recovery Equipment."

A-3.04 Runaround System (Closed Loop) Method. With the closed loop systems method, a hydronic system transfers sensible heat from the exhaust air to the outdoor air using water, glycol, or some other sensible heat fluid. See Figure A-7.

APPENDIX A (Continued)

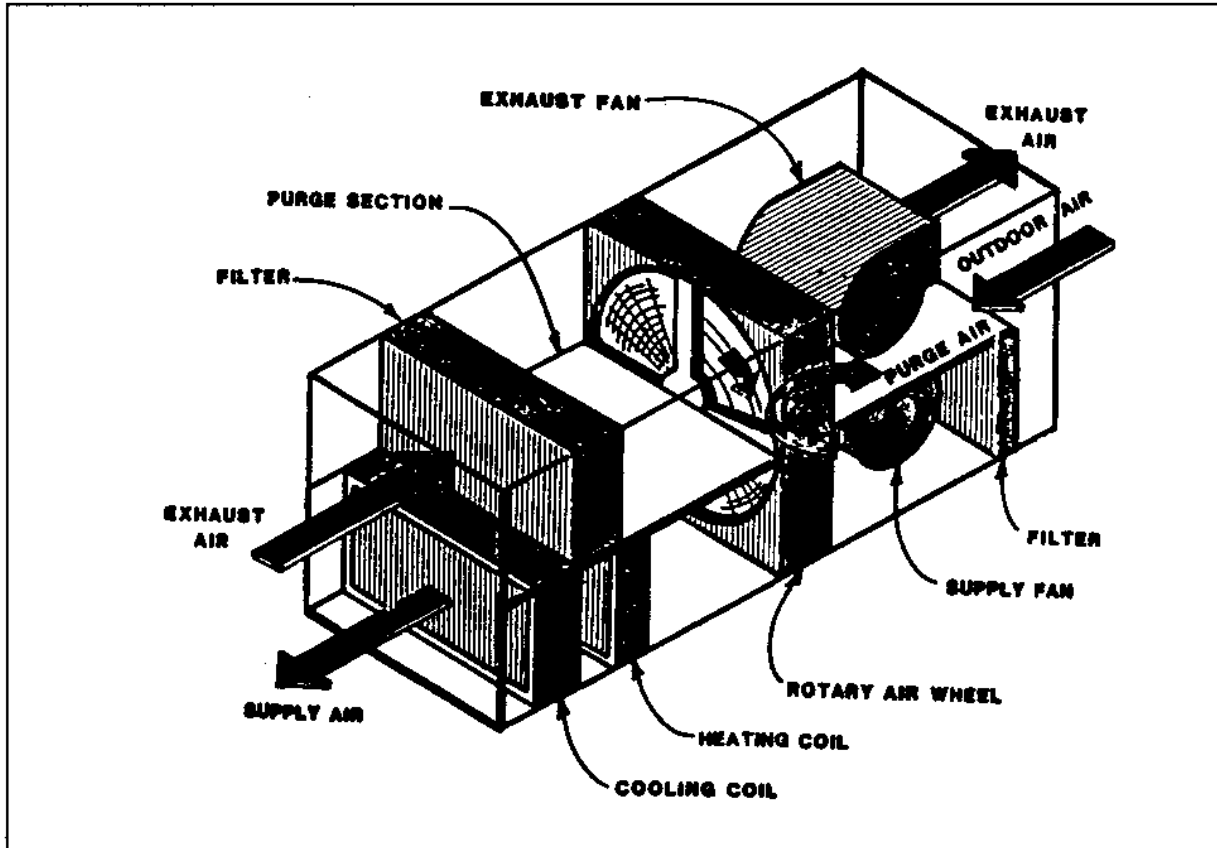

Figure A-3  
Exhaust Air Heat Recovery With Rotary Air Wheel



APPENDIX A (Continued)

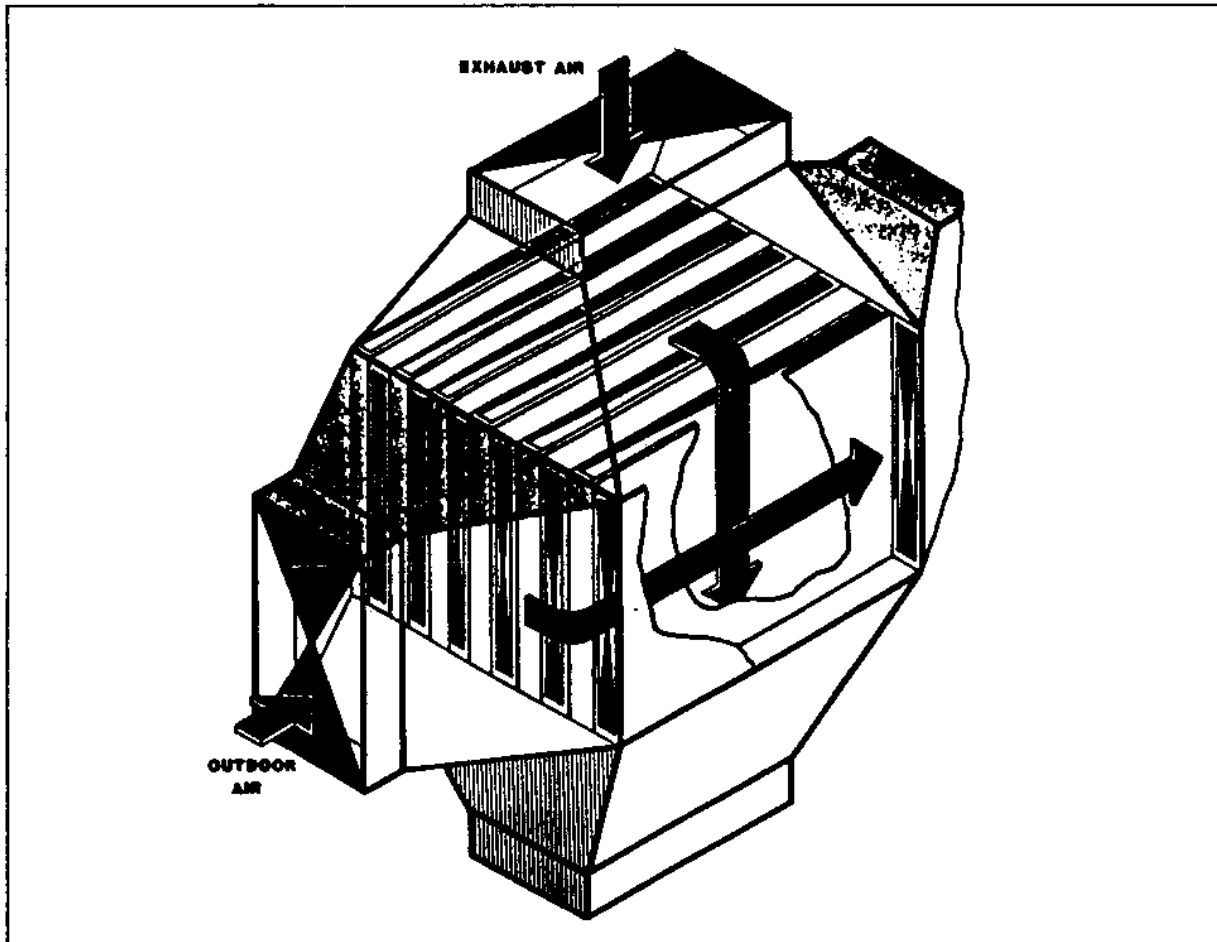

Figure A-4  
Exhaust Air Heat Recovery With Counterflow Pattern  
Static Heat Exchanger

APPENDIX A (Continued)

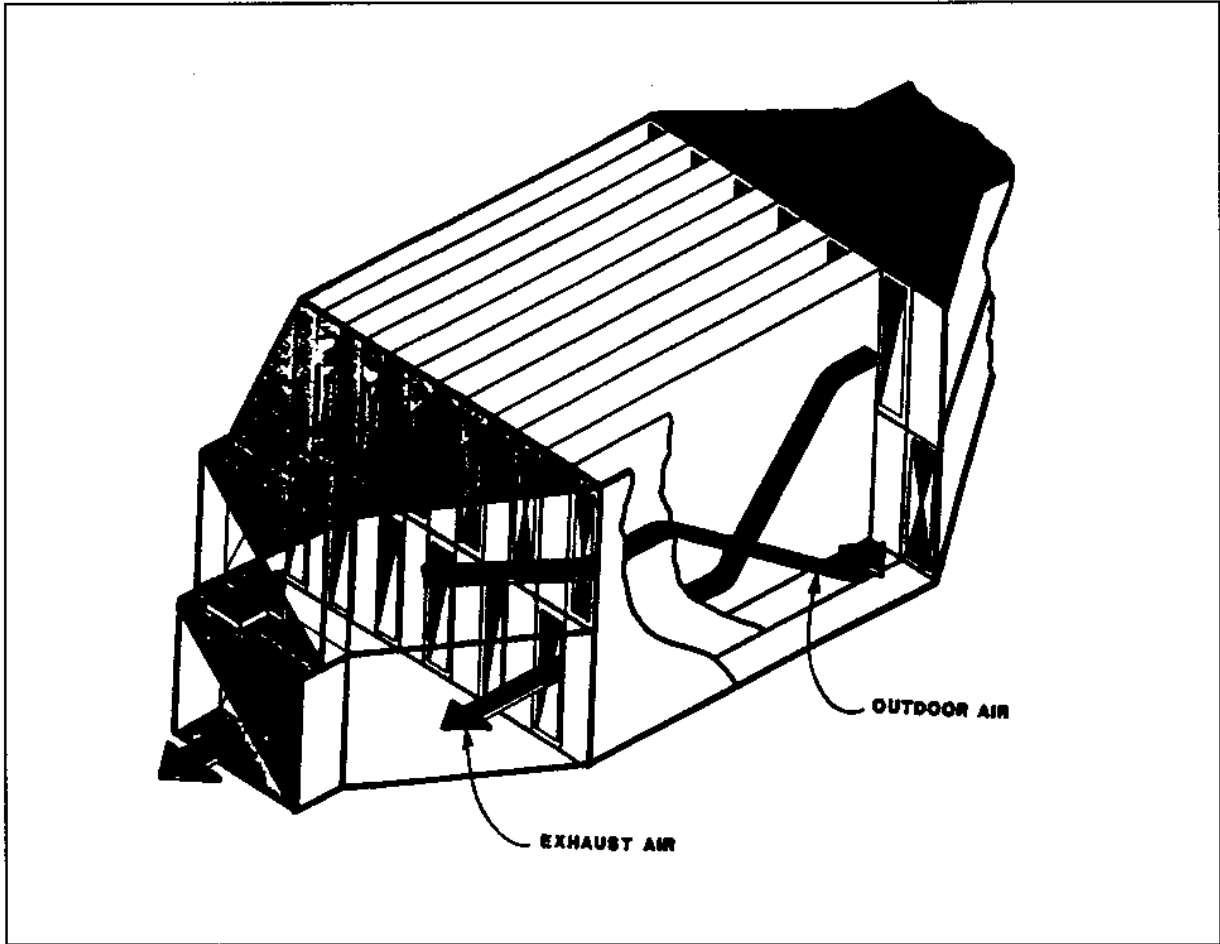

Figure A-5  
Exhaust Air Heat Recovery With Crossflow Pattern  
Static Heat Exchanger

APPENDIX A (Continued)

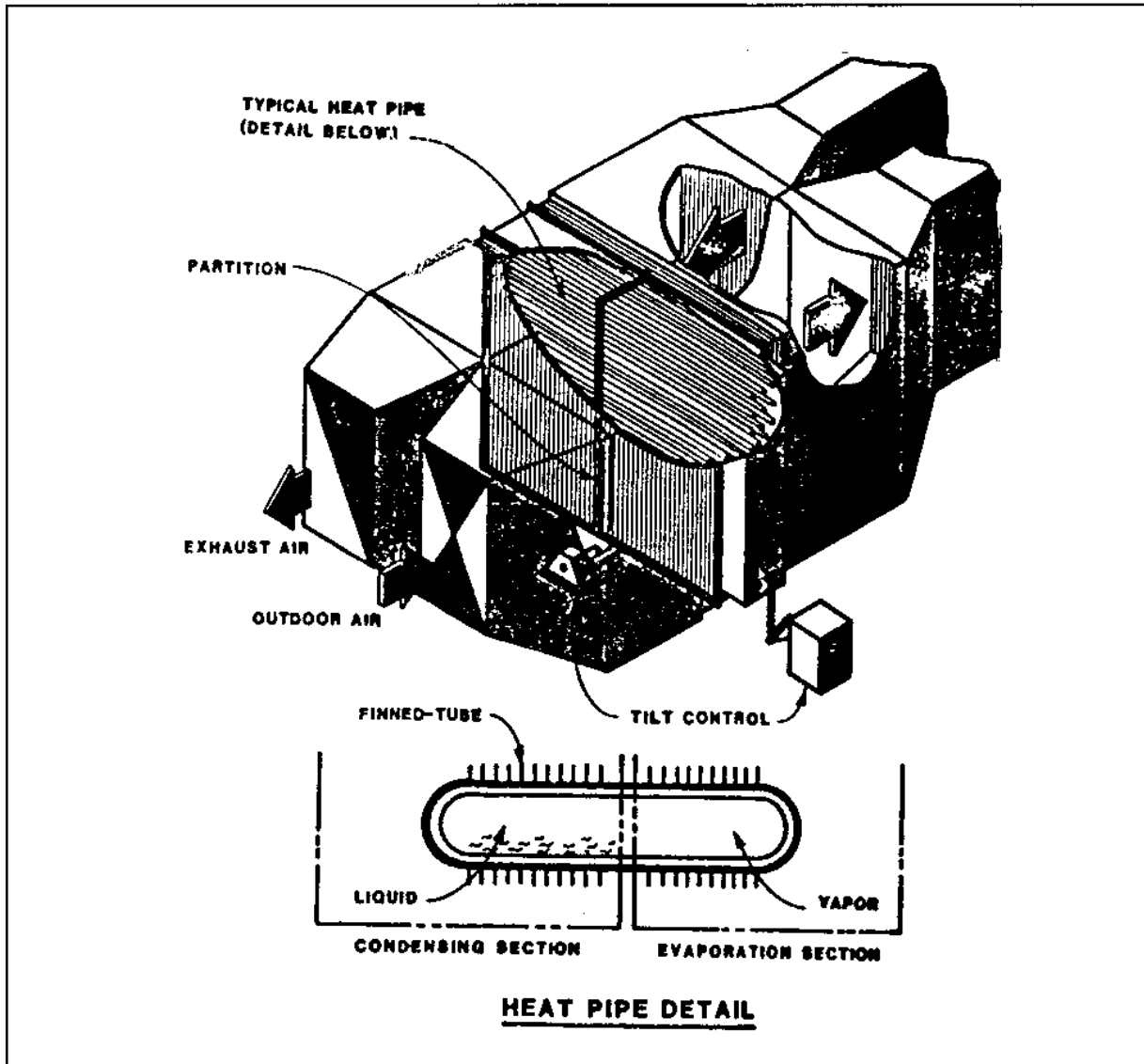

Figure A-6  
Exhaust Air Heat Recovery Method With Heat Pipe

APPENDIX A (Continued)

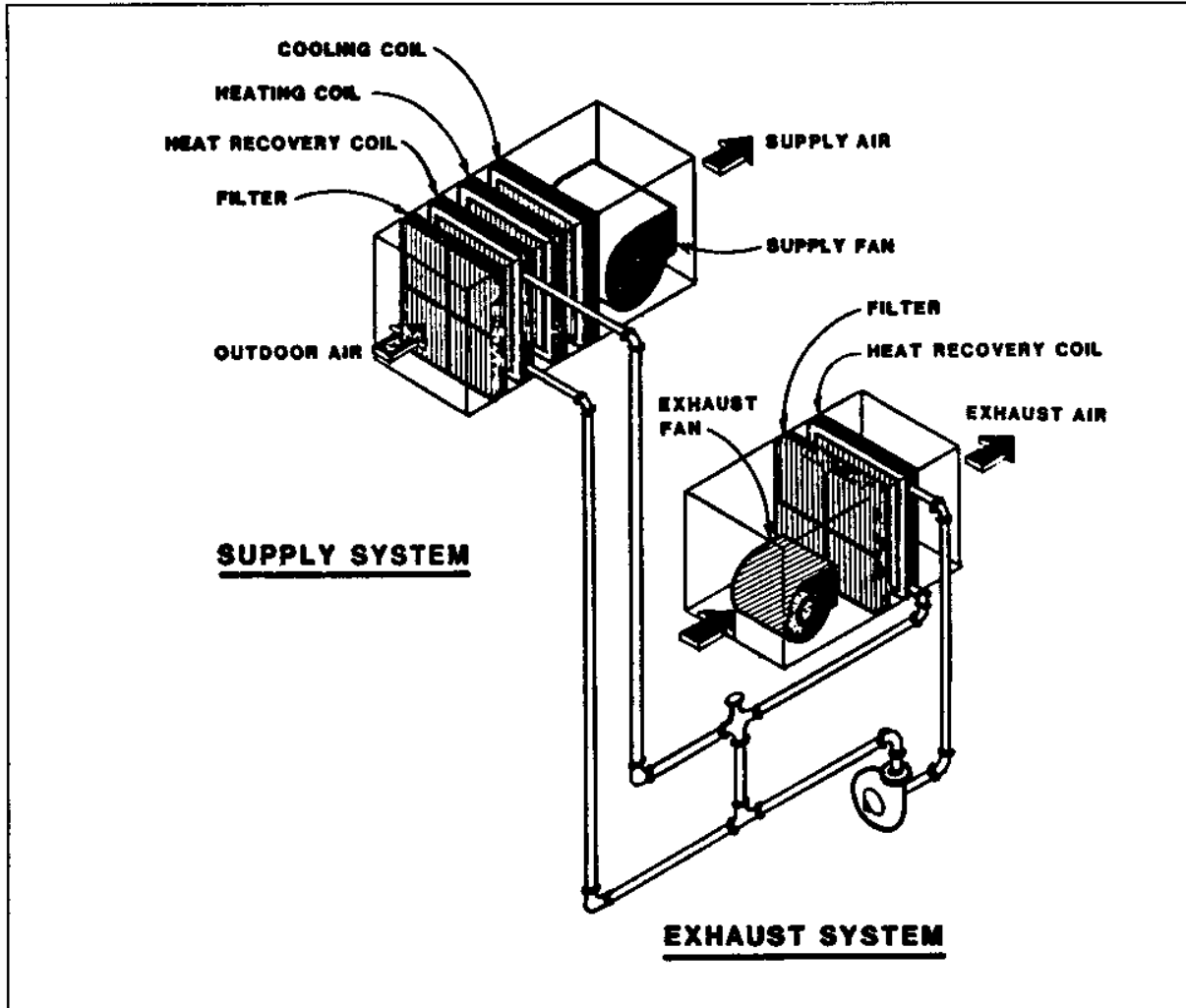

Figure A-7  
Exhaust Air Heat Recovery Method  
With Runaround (Closed Loop) System

## APPENDIX A (Continued)

The closed loop method consists of two coils (one in the supply system and one in the exhaust system), a pump, and a closed pipe loop. This method can be expected to increase the outdoor air temperature by 60 to 65 percent of the outdoor air and exhaust air temperature difference. If the winter design temperature is 32 degrees F or below, this system requires an antifreeze solution.

A-3.05 Runaround System (Open Loop) Method. The open loop method transfers sensible and latent heat. This is an air-to-liquid, liquid-to-air enthalpy recovery system where working fluid flows into each cell with the aid of a pump, in a manner similar to cooling tower flow. See Figure A-8. Sorbent liquid used with this system can be bacteriostatic, if necessary. The open loop method shall not be used for high temperature applications.

A-3.06 Ancillary Components. Ancillary components for exhaust air heat recovery methods include:

- a) Energy recovery devices for supply/exhaust filters,
- b) Preheat coils,
- c) Backdraft dampers,
- d) Exhaust dampers,
- e) Recirculation dampers,
- f) Face and bypass dampers, and
- g) Drainage provisions.

Controls and ancillaries shall be shown on drawings and supplemented by specifications, as necessary. Select the minimum acceptable energy transfer effectiveness and the maximum acceptable cross-contamination.

A-3.07 Condensate Cooler/Hot Water Heat Recovery Method. The condensate cooler/hot water heat recovery method uses a heat exchanger, which removes heat from condensate not returned to the boiler. This recovered heat can be used to preheat domestic hot water, boiler makeup water, or low temperature water return to boiler or heat exchanger.

APPENDIX A (Continued)

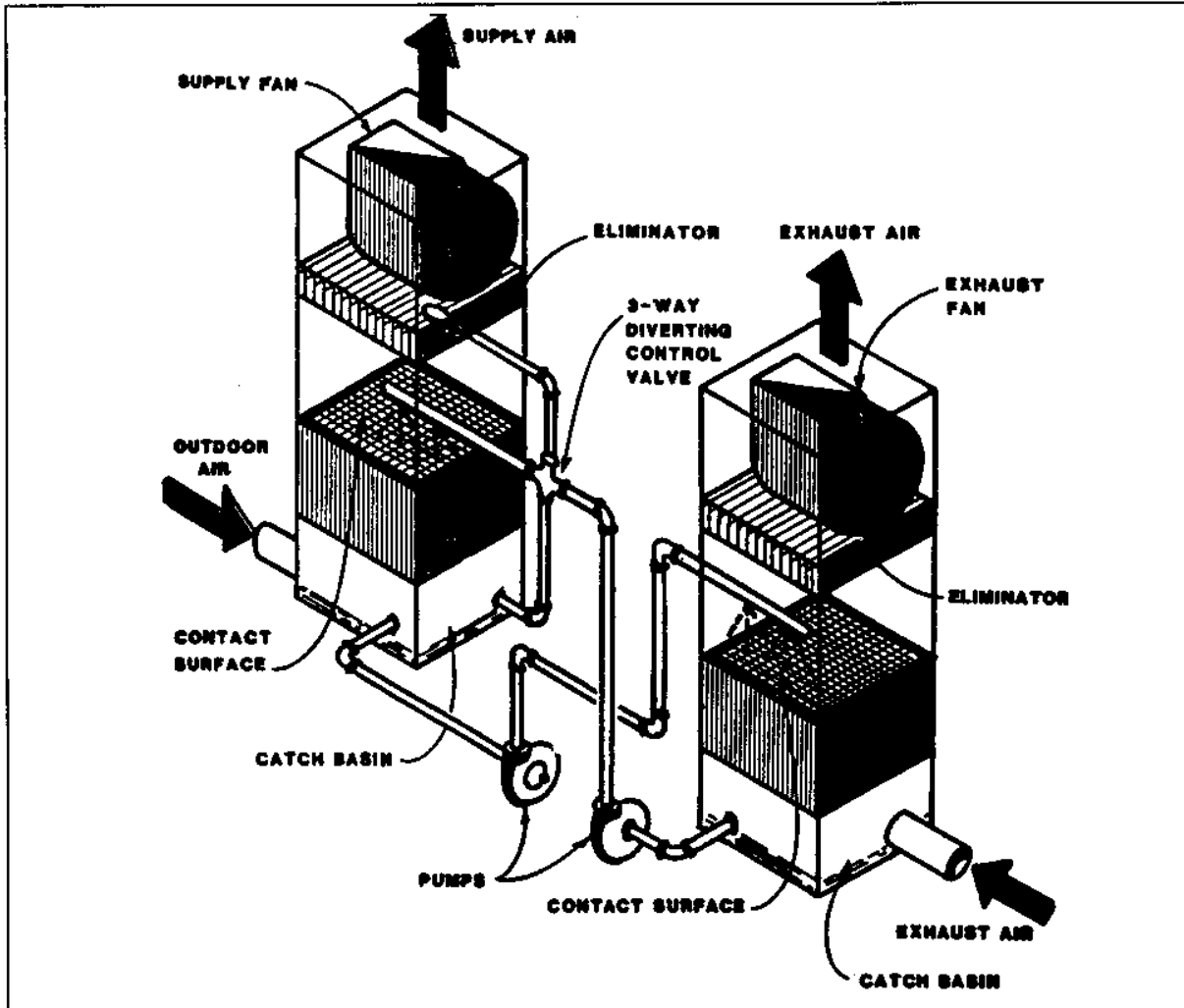

Figure A-8  
Exhaust Air Heat Recovery Method  
With Runaround (Open Loop) System

## APPENDIX A (Continued)

A-3.08 Heat-of-Light Heat Recovery Method. The sensible heat given off by the lighting fixtures is a large portion of the total cooling load. Recovery of this heat reduces energy usage both by reducing the room cooling load and by recovering usable heat. In some instances, the efficient removal of heat-of-light that does not enter the room may reduce the air supply to the room below that which is desirable. Verify that effective air circulation is maintained. Recommended methods of heat-of-light recovery are the light troffer and induced air methods. Where life cycle cost effective, use heat-of-light recovery method in air conditioned spaces. Do not use for clean rooms, animal laboratories, and laboratories with toxic, explosive, or bacteriological exhaust requirements.

A-3.09 Light Troffer Method. The light troffer method removes space air by pulling it through a light troffer or through a light fixture, and transfers it into the ceiling plenum where it is routed into the return air system. See Figure A-9. With this system, the room cooling load is reduced. Also, less air is required to cool the room, making it possible to use smaller duct and fan systems. Do not use for VAV systems.

With this method, the total cooling load is substantially reduced for outdoor air supply systems, but not as significantly for systems not capable of providing 100 percent outdoor air. This technique also reduces the luminaire surface temperature and, therefore, increases ballast and lamp life.

A-3.10 Induced Air Method. The induced air method removes air from the space by pulling it through the light troffer or through a lighting fixture, and transfers it into the ceiling plenum, to be recirculated or discharged outdoors. See Figure A-10.

A-3.11 Refrigeration Heat Recovery Method. The refrigeration heat recovery method uses heat rejected from the refrigeration machine. This method uses four different techniques:

- a) Conventional refrigeration machine method,
- b) Heat pump method,
- c) Single condenser water circuit method, and
- d) Double condenser water circuit method,

APPENDIX A (Continued)

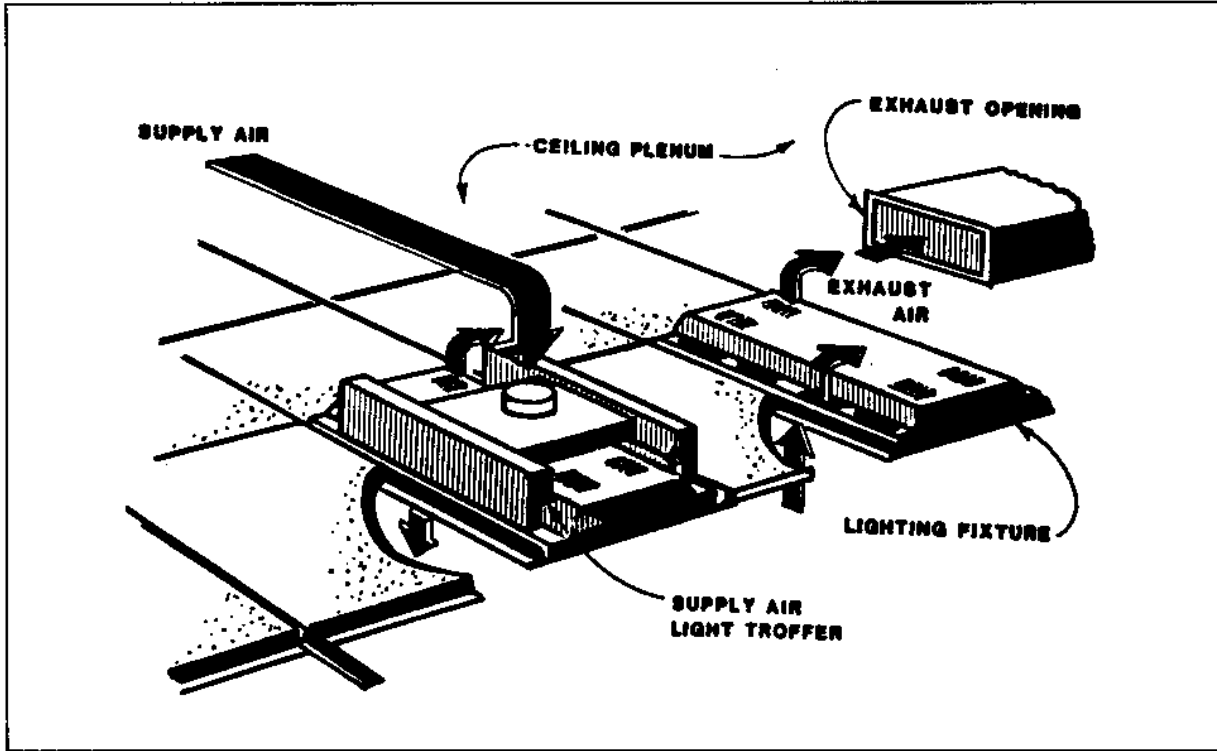

Figure A-9  
Heat-of-Light Recovery Method With Light Troffer



APPENDIX A (Continued)

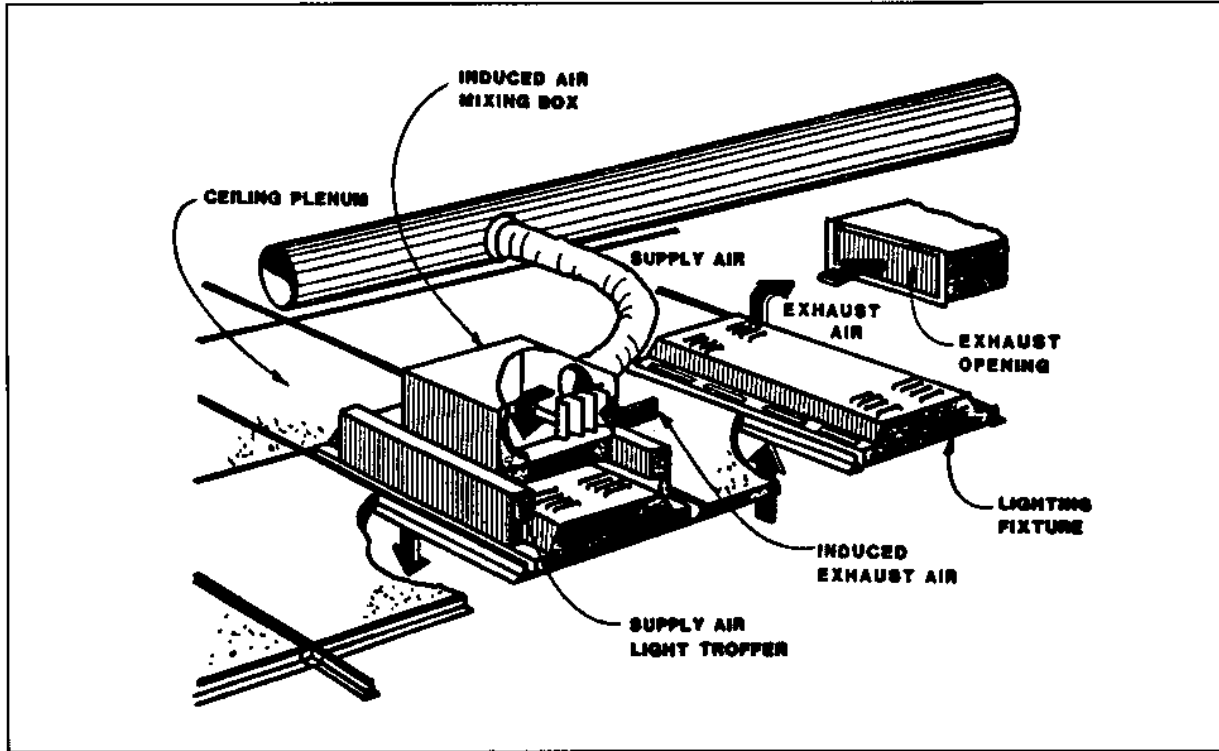

Figure A-10  
Heat-of-Light Recovery Method With Induced Air

## APPENDIX A (Continued)

The refrigeration heat recovery method is suitable when a refrigeration-type compressor is used, and when simultaneous heating and cooling of one or more spaces is required.

A-3.12 Conventional Refrigeration Machine Method. The conventional refrigeration machine method uses a direct expansion cooling coil in conjunction with either a hot water or refrigerant coil. See Figure A-11 and Figure A-12.

A hot water heating system extracts heat from the refrigerant through a heat exchanger. For direct air heating, a condensing refrigerant coil is used instead of a heat exchanger and water pump. This method is used for lower capacity systems with reciprocating compressors. An air-cooled condenser is used to reject heat when space heating is not required.

A-3.13 Internal Source Heat Pump Method. See Figure A-13.

A-3.14 Single Bundle Condenser Water Circuit Method. The single bundle condenser water circuit method uses a cooling coil in conjunction with a hot water system for heat recovery. When space heating is not required, heat is rejected through an evaporative cooler, a heat exchanger, and an open cooling tower.

Application of this system is limited to a maximum water temperature of 110 degrees F. This system can be used with any compressor type. See Figure A-14.

A-3.15 Double Bundle Condenser Water Circuit Method. The double bundle condenser water circuit method incorporates two separate condenser water circuits - one for the heating system and one for the cooling tower system. Water temperatures up to 125 degrees F can be obtained by using higher compressor speeds, larger impellers, or more than one stage. See Figure A-15.

Selection of a heat recovery machine is critical because relatively high condensing temperatures are required. To prevent surging of the compressor under operating load and required condenser water conditions, lower the condensing temperatures under partial load conditions. Units shall be selected to operate above 50 percent of full load at all times. Storage tanks may be incorporated into a double bundle condenser water circuit system.

APPENDIX A (Continued)

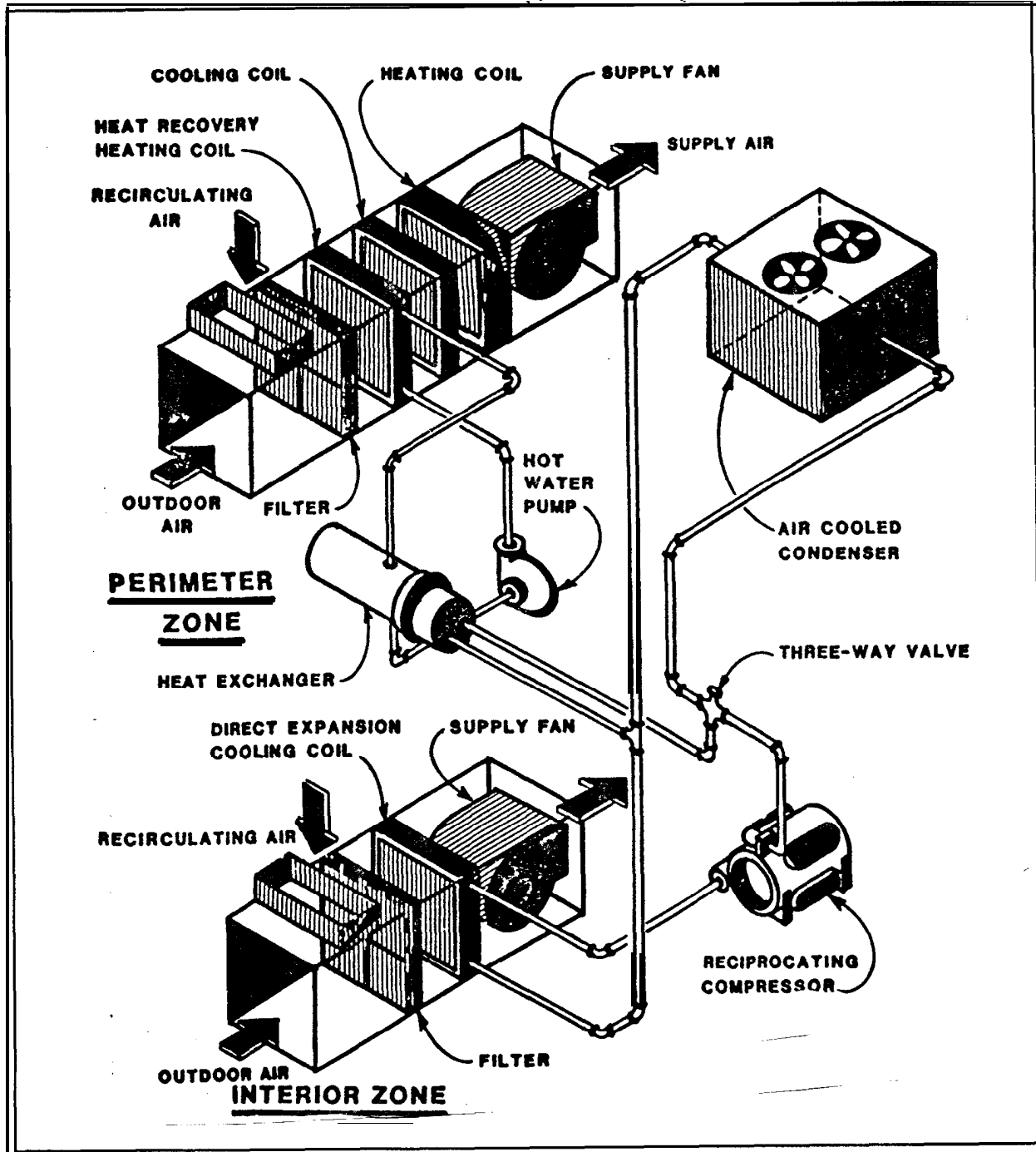

Figure A-11  
Refrigeration Method Heat Recovery With Conventional  
Refrigeration Machine Using Hot Water Coil

APPENDIX A (Continued)

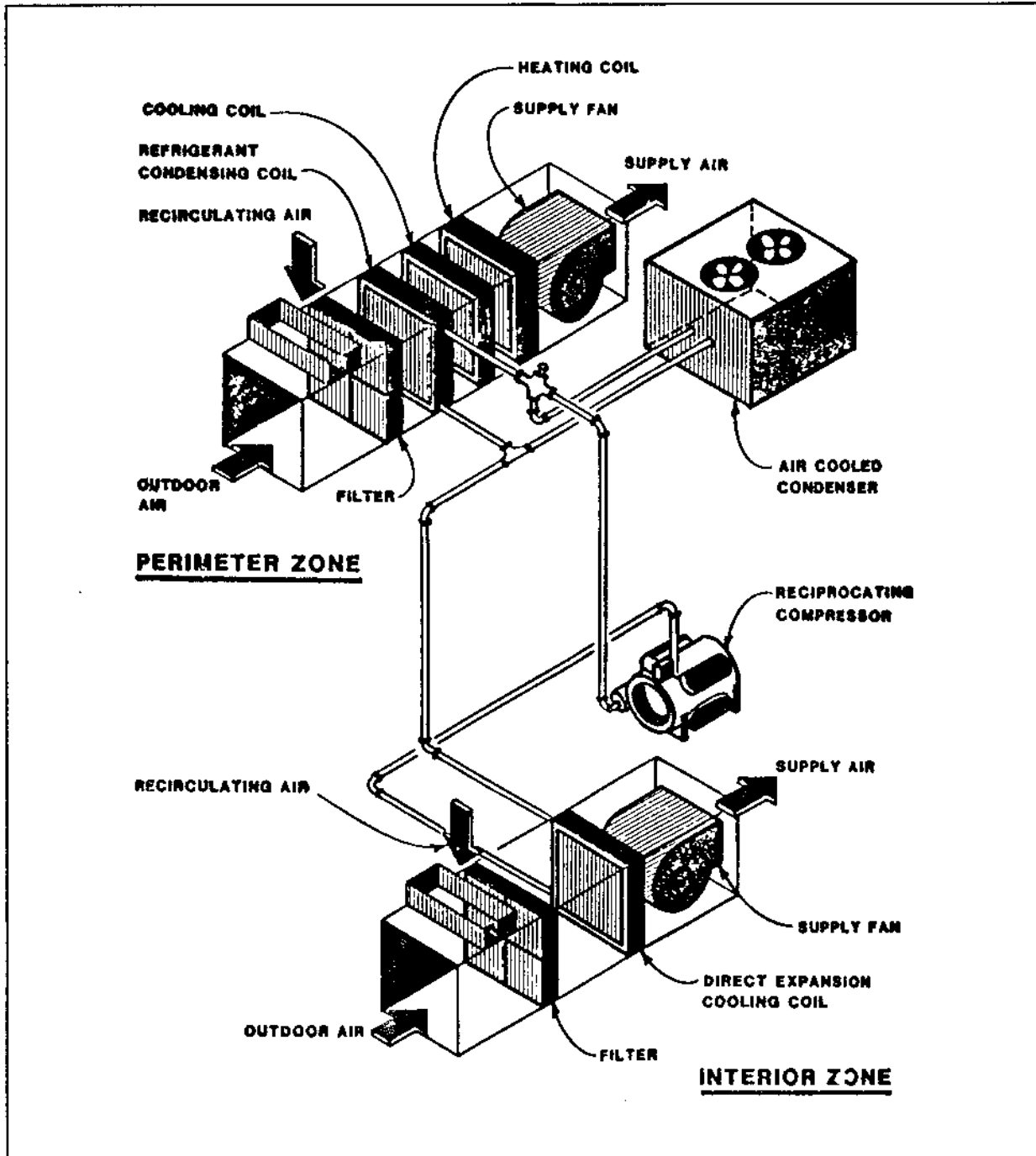

Figure A-12  
Refrigeration Method Heat Recovery With Conventional  
Refrigeration Machine Using Refrigerant Coil

APPENDIX A (Continued)

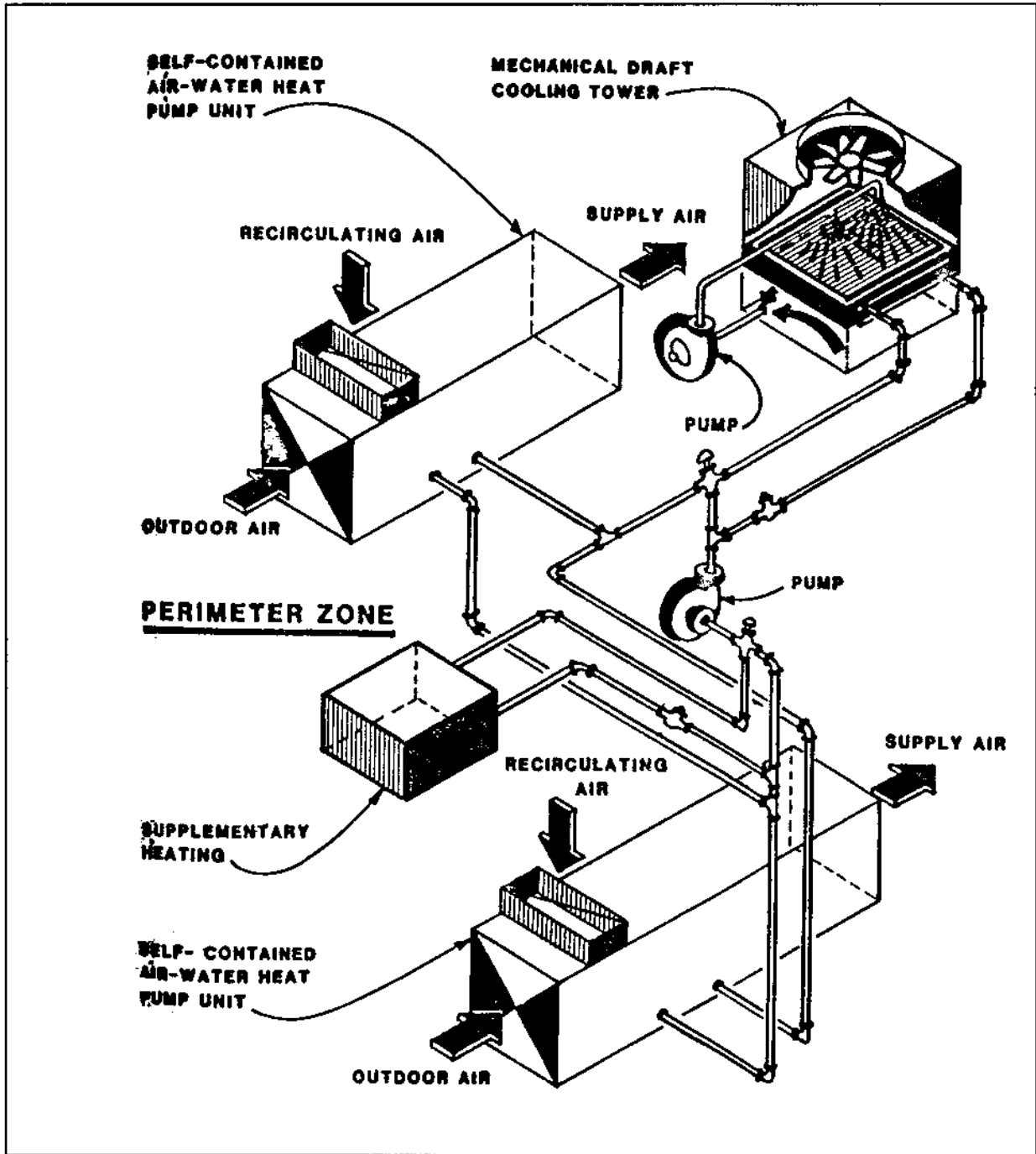

Figure A-13  
Refrigeration Method Heat Recovery With  
Internal Source Heat Pump

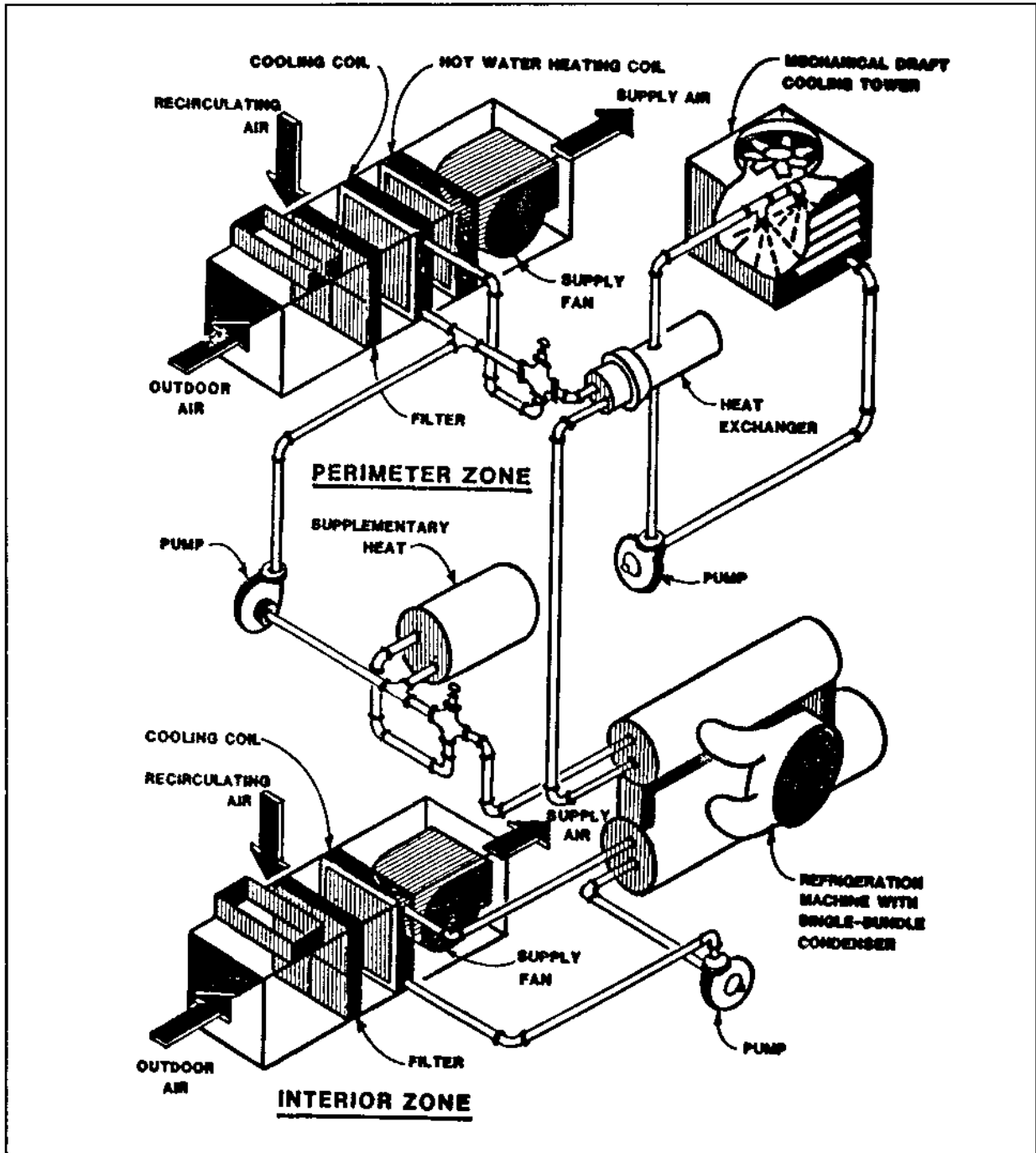

Figure A-14  
Refrigeration Method Heat Recovery  
With Single Bundle Condenser Water Circuit Method  
and Open Cooling Tower

APPENDIX A (Continued)

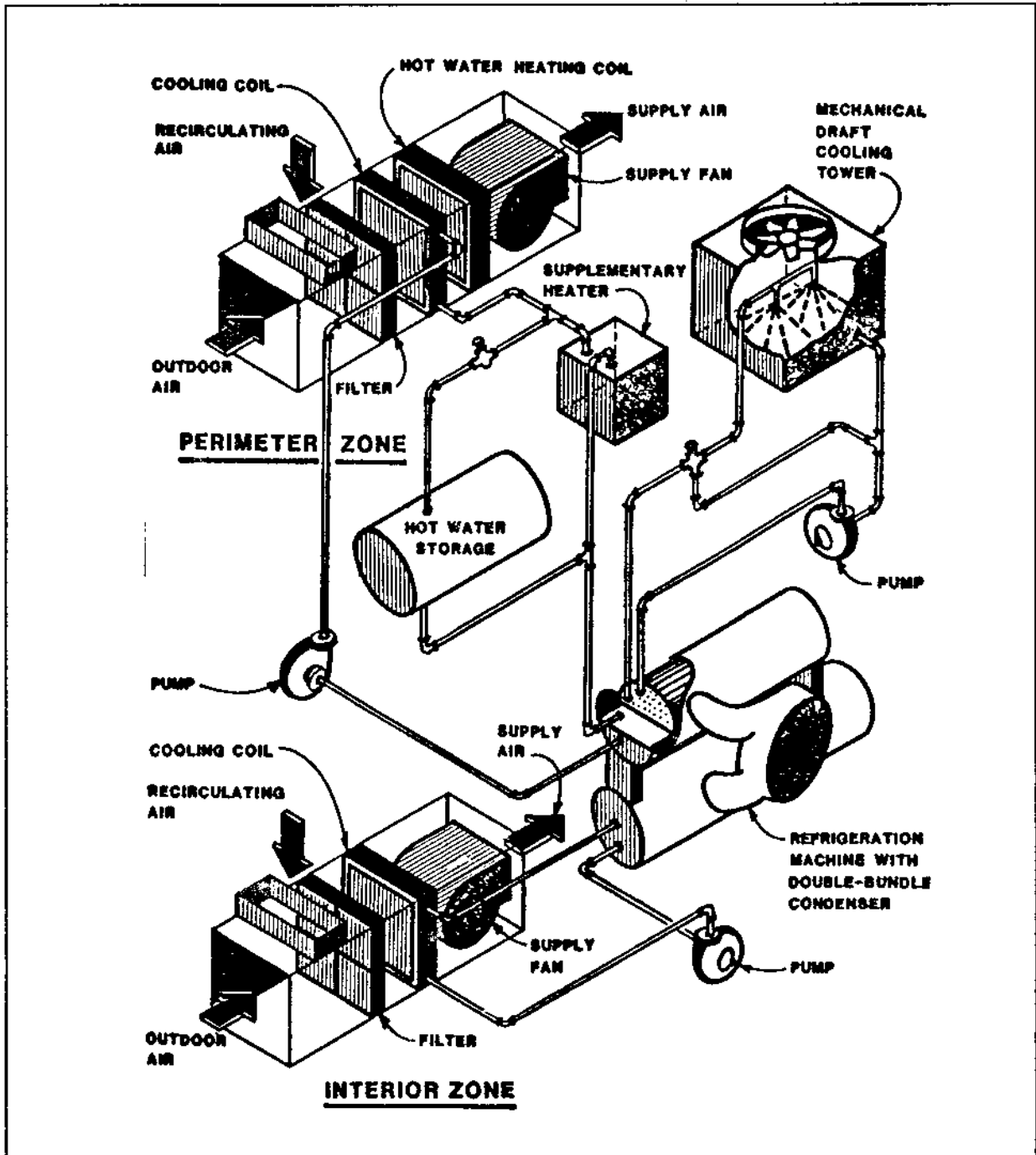

Figure A-15  
 Refrigeration Method Heat Recovery  
 With Double Bundle Condenser Water Circuit Method

## APPENDIX A (Continued)

Complete an economic evaluation for use of heat recovery machines in large systems. If economically justified, the large system can be designed for multiple machine installations by using conventional machines in conjunction with heat recovery machines. The selection of a double tube bundle machine is a design function where standby low-grade demand exists. Where this cannot be justified, use a single tube bundle machine.

A-4.00 HVAC System Management. Cycling the boiler and refrigeration chiller in a pattern responsive to the time of day and prevailing weather conditions reduces energy consumption by reducing excess heating and cooling capacity during operating hours. For large buildings, a computerized energy management system may be justified. These systems can analyze weather conditions, building and system characteristics, and HVAC operating conditions. Energy management systems then adjust various controls to provide optimum energy use.



APPENDIX B  
ENGINEERED SMOKE CONTROL SYSTEMS

B1.00 Introduction. By the very nature of this type of system; some of the requirements of NFPA 90A will need to be modified or suspended. If air movement or pressures from the duct system are necessary to confine or control the flow of smoke, fans should not be shutdown or dampers closed.

B2.00 Specific Design Guidance

a) Suggested for use in large zones.

b) Smoke dampers should meet UL 555S, Standard for Safety Leakage Rated Dampers for Use in Smoke Control Systems. These are made in ratings of zero to four. Class 1 is a good tight damper. Use Class 1 dampers where the return or exhaust air may meet the outside air to prevent contaminating the supply air with smoke. Class 2 or Class 3 dampers (with more leakage) may otherwise be used for smoke zone dampers.

c) Return ducts used for smoke purging should be steel fabrication. Supply ducts should be insulated for protection from fire outside the duct.

d) Fans used for smoke exhaust should be rated for 750 degrees F continuous duty. Use an extended shaft and a commercially available propeller on the shaft to blow air onto the motor. The air temperature in the fire room may reach 1,400 degrees F, but this may be diluted with 70 degrees F air from other rooms to permit use of an ordinary fan. Do not put the motor in the airstream and do not use an aluminum fan wheel. Do not stop the smoke exhaust fan during a fire.

e) Specify acceptance testing of the smoke control systems.

APPENDIX C  
DESIGN DO'S AND DON'TS FOR VAV SYSTEMSC-1.00 Introduction

C-1.01 Scope and Criteria. This appendix is intended for use by qualified engineers who are responsible for preparation and review of plans and specifications for construction of VAV, HVAC, and dehumidifying systems. It complements the requirements of NAVFACENGCOCOM and DOD manuals and instructions for the construction of HVAC systems. The designer is reminded that normal construction and maintenance problems encountered with all types of HVAC systems are not covered here, but should be fully considered in the design.

C-1.02 Excellent Facilities. The objective of HVAC system design is to provide excellent places to work and live for Navy and Marine Corps personnel. The goal is not only to minimize the life cycle cost of the facilities, but also to maximize the performance of the people who use the facilities. VAV systems offer enhanced comfort by allowing economical flexibility in zoning, better temperature control, better passive humidity control at part load, and greater energy efficiency.

C-1.03 Importance of Design. Navy VAV systems often do not perform as the designer intends. An investigation of the causes of failure shows that considerable improvement in the success of VAV can be achieved by special attention to good design practices. This appendix is intended to provide feedback to alert the designer to recognize those areas where careful attention can prevent deficiencies commonly found in Navy VAV systems.

a) VAV systems incur problems for the same basic reasons that other types of air conditioning systems do. They are either improperly designed, constructed, or operated and maintained.

b) Deficiencies in design often result from both technical and practical aspects of the design. Improper practical decisions often occur in the following areas: (1) lack of consideration of the constructability of the design, (2) failure to appreciate the importance of designing systems that can be operated and maintained, and (3) failure to communicate in sufficient detail the design intent and thus leaving too many decisions to the contractor.

c) Deficiencies in construction, inspection, and acceptance occur primarily in three areas: (1) the system may

## APPENDIX C (Continued)

not be installed as designed, (2) the system is installed to meet requirements of the design and submittals but quality of workmanship is such that the system will not function properly, and (3) although construction might be satisfactory in all respects, acceptance testing is of poor quality and latent defects in the systems go undetected.

d) Operation and maintenance deficiencies can occur from insufficient or improper training, the system receiving inadequate operating and maintenance attention, and the system receiving well meaning but misguided operation and maintenance attention.

e) A failure in any of these areas can be fatal to the successful operation of a VAV system.

C-1.04 System Simplicity. The most common fault of the majority of designs is that the systems are too complicated to work reliably. Some systems never work initially, others fail because Naval operation and maintenance personnel do not understand them sufficiently to keep them working as designed. The chief area of concern is control systems. A designer is always tempted to add features to improve performance and conserve energy but must weigh the potential benefits against the additional cost and complexity. Feedback: On the average, systems have too many features and are too complex for the needs of the Navy. The designer should design systems that err toward simplicity, at the expense of features, and require minimum maintenance.

C-1.05 Early Coordination. Having experienced numerous problems on VAV systems, the Navy wishes to have a high level of interaction between the designer and the Engineer in Charge and will often want to give the designer more direction than is normal. To minimize design changes, it is important that there be good communication. This is particularly true in the early stages of the design. The designer shall communicate his design intent and the critical concepts of his proposed system, including simplicity in operation and maintenance, at the first submittal opportunity. This will prevent the necessity of changing the concept of the design.

C-1.06 Dry Climates. Many Naval facilities are located in humid climates and so there is a tendency to tailor design guidance for humid areas. There are also many Naval facilities located in dry and cold climates. The practice associated with design in these facilities can be considerably different. The

## APPENDIX C (Continued)

designer must be careful to fit his design to the area where he is working. Typical conditions in dry and cold climates are that: the relative humidity is low; the daily dry bulb range is high; the outdoor air economizer is effective (at least for night purging); the sensible heat ratio is high and systems are often designed primarily to handle the sensible load and to let the room relative humidity float as it will. Naval facilities located in dry and cold climates may require modifications to the criteria listed below.

C-1.07 Selection of Type of Control System. Design control systems as simple as possible to provide adequate control and give careful consideration to the following when selecting the type of control system:

a) Pneumatic Controls. Pneumatic controls seldom work consistently well in Naval facilities. Pneumatic controls require frequent maintenance and calibration at a level that is not usually performed by Naval personnel. Pneumatic systems are prone to fail from water or oil in the compressed air. Many pneumatic control systems are never set up properly by the installing contractor. Even hybrid control systems (e.g., DDC with pneumatic actuators) can have similar problems because the electric-to-pneumatic transducers have small passages that are vulnerable to moisture and oil in the compressed air. All other things being equal, pneumatic control is not a good choice for the control system; but if operation and maintenance personnel are expert in pneumatic controls, have adequate funds for maintenance, and refuse to use state-of-art systems, pneumatic systems may be justified.

b) Electric Control. For the sake of simplicity, electric VAV terminal unit controls may be used in conjunction with pressure dependent (PD) terminal units (refer to par. C-2.10). This type of zone temperature control requires only the simplest of control sequences and therefore, will be easier for Naval operation and maintenance personnel to understand and maintain. Electric controls for the central equipment (e.g., CHW valve and control, etc.) are in common use and are suitably rugged, however, may not be accurate enough for the application.

c) Analog Electronic Control. If pressure independent (PI) terminal units are used, it will be necessary to have electronic controls. Analog electronics usually introduce additional levels of complexity whose advantages can be outweighed by the likelihood that they will not be understood by

## APPENDIX C (Continued)

the operating and maintenance personnel. It is recommended that electronic controls be used with as simple a sequence as possible.

d) DDC. DDC is the state-of-art of control systems and is in common use throughout the industry. Navy DDC systems are distributed (have controllers located near the equipment being controlled) and usually include a means for the operator to diagnose HVAC operation from a remote location. A DDC system is the system of choice for Naval projects if the facility operating and maintenance personnel are qualified in DDC systems or, at least, are willing to take the recommended training and make a sincere effort to properly use DDC. The designer should not overdesign the DDC system, should make it simple, and as user friendly as possible. It is critical that quality DDC sensors be used which have long term (5 years) stability to minimize maintenance and calibration while providing accurate conditions. DDC systems may incorporate energy management strategies in addition to normal control functions with little or no additional cost.

#### C-2.00 Do's and Don'ts

C-2.01 Do not oversize the system. Do not add safety factors in load calculations. The calculation methods already have an adequate safety factor included. Feedback: Many Navy VAV systems are significantly oversized. This not only costs more, but it handicaps the system in performing the already difficult task of providing comfort under difficult part load conditions commonly seen in humid, coastal environments where many Navy installations are located. Because of the inherent diversity factor in VAV systems, they are more "forgiving" of capacity shortages than are constant volume systems.

C-2.02 Use computerized load calculations based on the ASHRAE transfer function method. The manual use of the total equivalent temperature difference/time averaging (TETD/TA) method or the cooling load temperature difference/cooling load factor (CLTD/CLF) methods are not as accurate and require engineering judgment which typically leads to unnecessary conservatism.

C-2.03 Design for diversity. Select central air handling equipment and heating/refrigeration systems for "block" loads. Spread diversity appropriately through the supply ducts, taking full diversity at the air handling unit, and lessening diversity

## APPENDIX C (Continued)

when moving away from the air handling unit toward the VAV terminal units, until no diversity is taken at the distant VAV terminal runouts.

C-2.04 Design and specify for both peak and part load conditions. Submit design calculations verifying that careful consideration has been given to the following areas:

a) Consider the psychrometric performance of the cooling coil (taking into account the method of capacity control) during difficult off peak conditions when the room sensible heat ratio can be significantly reduced. Select appropriately difficult off peak conditions for analysis. At a minimum, show how the system will perform when sensible load due to solar is lost while latent loads remain constant. This is not necessary in dry climates. The VAV system may operate with 100 percent outside air during warm-up or on maximum heating days.

b) When selecting a fan for a VAV system, submit design calculations verifying the system has been analyzed at the following three points: (1) normal peak load (including diversity), (2) maximum cooling load (no diversity with VAV box dampers open), and (3) minimum cooling load (with VAV boxes at the minimum flow condition). The supply fan should be scheduled/specified (cfm and pressure) to satisfactorily meet all three of these operating points. Submit design calculations and a typical fan performance curve showing all of these points plotted. A fan should never be selected which will become unstable or overload anywhere on its operating curve.

c) Consider limiting the size of VAV air handling units to 10,000 cfm for flexibility and ease of maintenance. Plan for units to serve zones with different exposures to achieve unit diversity.

d) VAV terminal boxes should be sized with both maximum and minimum flows in mind. Schedules should indicate cfm, neck velocity, pressure drop, and noise criteria at both maximum and minimum flow (refer to par. C-2.11).

e) For air distribution devices, the minimum allowable "throw" should be scheduled for both maximum and minimum flow conditions.

f) If an outside air injection fan is used to maintain minimum ventilation, select a fan with a "steep" fan curve which will maintain a relatively constant flow regardless of mixing box

## APPENDIX C (Continued)

pressure. This analysis will be similar to that used for specifying the supply fan. Knowing the range of total static pressure expected in normal operation of the supply fan, estimate the expected range of mixing box pressures. Select the fan to deliver design minimum ventilation at an average system operating point (typically less than design peak). With this method of selection, the fan will deliver slightly more than design under peak flow conditions and slightly less than design under minimum flow conditions. The fan should be scheduled/specified to satisfactorily meet flow requirements at each of these three operating points.

g) Submit detailed computerized design calculations (this is mandated by the static regain method for sizing) which indicate the amount of diversity used for sizing ductwork and where the diversity was applied.

h) It is recommended that the system be designed for 8 to 12 air changes per hour with a minimum supply airflow of 4 air changes per hour.

C-2.05 Design supply ductwork using the static regain method. This will require computerized ductwork design analysis. Design return ductwork using the equal friction method. The static regain method keeps the static pressure in the supply system more nearly constant throughout. This enhances the inherent control stability of the system. It also greatly assists in naturally balancing airflow through the system minimizing any advantage for using PI terminal boxes. Using the static regain method requires that more attention be given to the design of the duct system but this is effort well spent.

C-2.06 To control humidity and for simplicity, design for a constant cooling supply air temperature. The leaving air temperature should be controlled using a chilled water valve modulated to maintain supply air temperature as sensed by a leaving air sensor. Resetting the supply air temperature upwards increases the sensible heat ratio of the coil and leads to high space relative humidity and poor indoor air quality. The potential to save refrigeration energy by raising the cooling supply air temperature is more than offset by the increased fan energy needed to move more air. In addition, changes in supply air temperature can lead to condensation on and around diffusers. Exception: There are cases where, to prevent overcooling at minimum flow or to minimize reheating, resetting the cooling

## APPENDIX C (Continued)

supply air temperature might be appropriate. Also there are cases in dry climates where it would be permissible to vary supply air temperature.

C-2.07 Do not use a return air fan in a VAV system. Measuring and control requirements for tracking the return air fan with the supply air fan are too demanding to work in a Naval VAV system. In most cases a return fan is unnecessary to return air to the HVAC unit. In cases where the pressure drop in the return duct exceeds the drop for outdoor air, the mixing box may be at a lower suction pressure. Select outside air and return dampers with this in mind.

C-2.08 Economizers should be used when significant benefits can be shown. (Clearly dry or cold climates are cases where economizers can be effective.) Feedback: Economizers in Navy VAV systems fail in a majority of cases due to complex arrangements. Keep economizer systems simple and use only outdoor air dry bulb sensors for changeover. The economizing feature can save a lot of energy in many applications but the designer must confer with the appropriate NAVFACENGCOCOM EFD or EFA when using this design.

a) Economizers should have outdoor air dry bulb type changeover instead of outdoor air versus return air comparators or enthalpy type changeovers.

b) Economizers should only be used when the system can be designed with gravity relief. Return or relief fans should not be used.

C-2.09 Maintaining Ventilation Air. In most systems there are circumstances under which satisfying the cooling load will not adequately ventilate the space. Unless it can be shown that this is not the case, the designer shall design a positive means of maintaining ventilation rates during minimum flow conditions, to maintain IAQ. Select minimum positions of VAV terminal units to meet this requirement. Note: It is impossible with a VAV system to absolutely maintain a minimum ventilation airflow to any space. The best that can be done is to maintain a constant ventilation airflow on a per air handling unit basis and recognize that ventilation will be improved in any zone that is shorted by mixing between rooms (especially in zones where fan-powered boxes are used) and shorted rooms tend to be those where people and lights are not present, and thus the ventilation requirements are lower anyway. Use ASHRAE Standard 62 to maximize IAQ.



## APPENDIX C (Continued)

To maintain a constant outside air quantity being drawn in and supplied by the AHU, a separate outside air injection fan or PI VAV box should be used. Use of an injection fan is encouraged rather than a PI VAV box because it is a more reliable method of providing constant ventilation from a simplicity and maintainability viewpoint. The designer should be aware that PI units rarely work properly in Navy installations because of maintenance problems with PI velocity sensing hardware/controls. Properly working PI units, however, would be a more accurate means of providing a constant flow throughout a given range of mixing box pressures. A PI unit should be considered if the range of mixing box pressures expected is such that it would be difficult to specify a fan which would deliver acceptable flows throughout the range of pressure.

C-2.10 Pressure Dependent (PD) Boxes. The use of PD VAV boxes rather than PI boxes is recommended. Feedback: PI velocity resetting controls are often a significant contributor to failure of Navy VAV systems. When determining the type of VAV terminal units to use in a system, give careful consideration of the following feedbacks:

a) The most important feature touted for PI units is that they respond to fluctuations in system pressure and thus enhance control stability by reducing "hunting." However, when the supply duct system has been properly designed for static regain, there is no clear evidence that the use of PI units results in greater zone temperature control stability than when using PD units. The transfer functions and time constants in a typical VAV unit control are such that the potential benefits of velocity resetting are nullified by the disadvantages of the additional and complicated control loop.

b) PI controls claim to render the whole system virtually self-balancing. However, in a system with PD controls and a well designed static regain duct system, the VAV dampers respond to changes in load sensed by the thermostat and respond to balance the air in a similar way.

c) Maximum and minimum airflow limiting is a feature that is inherent with PI control units. However, there is some question as to how well the velocity sensors used for this purpose actually measure flow (setpoints are at the extreme low end of their range). Some manufacturers say the velocity loop readily drifts out of calibration and must be auto-calibrated regularly by using a DDC system. The problem is worse at lower airflow. A differential pressure flow ring or flow cross is

## APPENDIX C (Continued)

accurate only down to about 400 fpm (which unfortunately might be as high as 33 to 50 percent of maximum flow in many cases). Since desired minimum flow will usually be less than this, the differential pressure PI is not accurate for controlling minimum flow. The other common method uses a hot wire anemometer or similar device for sensing. This is not very good because the sensor is a single point in the inlet duct rather than a multi-point device (as used by the flow ring described above). It would only be accurate for a box that had many diameters of straight duct upstream (not the usual case). In addition, the response time is too slow for good PI control.

d) Minimum flow can be set on PD units by installing mechanical stops, by setting the actuator stroke through linkage adjustments, or by other similar means. These are straightforward testing and balancing procedures.

e) PI costs somewhat more than PD on the average, is much more complicated for maintenance personnel, and the additional control components are more prone to failure.

f) If PI is used, however, the designer must be careful to specify that supply maximums and minimums are checked after the equipment is installed. Factory adjustments have proven to not be an adequate guarantee that the installed equipment will function as needed.

C-2.11 Carefully consider the throttling characteristics when selecting the type and size of VAV terminal units. The installed characteristic curve of a throttling damper expected to modulate supply air to a space, is a function of the inherent characteristic curve of the device and the ratio of the system pressure drop to the drop across the damper at maximum flow. As the pressure drop of the damper at maximum flow is reduced (by selecting larger and larger dampers for a given flow rate--a practice promoted by the desire to save fan energy), the installed characteristic tends to move across the spectrum toward quick opening characteristics. The geometry of butterfly dampers tends to exaggerate this shift. With dampers specially designed to retain linearity, this shift can be greatly reduced.

a) A shift toward quick opening increases the gain of the control component, i.e., a smaller part of its stroke is actually used for control. This is detrimental to the stability of the control system. The common tendency of selecting dampers with very low pressure drops can result in control that is nearly

## APPENDIX C (Continued)

"two-position." It is better to pay some fan energy penalty and have a system that provides more stable control. Properly sized control dampers will be smaller than fan casings and have greater maximum flow pressure drops than those usually used.

b) If PI terminal units are used, sizing becomes even more critical. Oversizing the boxes to reduce maximum flow pressure drop results in low neck velocities, which in turn create problems for PI flow measuring devices. To minimize problems with sensing minimum flows in PI VAV boxes, size the box such that at minimum flow, the neck velocity will be at least 500 fpm.

C-2.12 Give special attention to linkages (VAV terminal unit damper, fan inlet guide vanes, and controllable pitch vanes). Feedback: Problems due to poorly designed/constructed linkages are very common in Naval VAV systems. Either specifically describe linkage requirements (because manufacturers are so different, this may be difficult for VAV terminal units) or at least require detailed shop drawings of linkages and pay close attention to them. Finally, linkages should be included in the specifications as a specific item to be performance checked during the acceptance testing of the system.

C-2.13 Pay close attention to Contractor's responsibility of coordinating which of his subcontractors provides VAV terminal units/controls/actuators. Feedback: Contractors' lack of coordination of the VAV terminal unit and controls often leads to problems which go undetected. Even though DOD specification policy recognizes only the Contractor as the single entity, and not the subcontractors (thus not stating who does what), careful attention to submittals in this area will avoid many problems. To help with this, the VAV boxes, thermostats, and associated equipment should be specified as a system and the Contractor be required to make his submittal for all items at the same time.

C-2.14 Whichever of the available methods of selecting supply air outlets is used, consider the full range of flow rates expected. Recognize the effects of room geometry on satisfactory performance (e.g., the Coanda effect depends upon having a flat ceiling, without interruptions, etc.).

a) It is recommended that VAV supply diffusers be of the linear slot type capable of supplying air horizontally along the ceiling utilizing the Coanda effect to provide good air distribution. In cooling only applications, the diffusers should be located centrally in the space and blow in all directions. In

## APPENDIX C (Continued)

exterior spaces with fan-powered boxes, the location depends on the magnitude of the heating load. If the heating load is less than 250 Btuh per linear foot of exterior wall (including infiltration), the diffuser should again be located centrally and blow in all directions. If the heating load is between 250 and 400 Btuh per linear foot of exterior wall, the diffuser should be located near and parallel to the exterior wall and blow horizontally back into the room.

b) Diffusers which have operable internal dampers for varying airflow should not be used in lieu of conventional duct-mounted terminal units in a VAV system design.

C-2.15 Locate the static pressure sensor, for modulating fan capacity, out in the supply duct system, not at the fan discharge. Expect some field adjustment to be required to find the best location. In many systems, the first location is two-thirds the distance from the supply fan to the end of the main trunk duct. Sensors shall have proper static sensing elements.

Provide protection against overpressurization of the supply duct. This should be accomplished by a high limit duct static pressure sensor located at the fan discharge. This sensor should turn off the supply fan if the duct static pressure rises above setpoint and require manual reset of the supply fan.

C-2.16 Balancing dampers should not be necessary for VAV systems. If the supply ductwork is designed properly using the static regain method (refer to par. C-2.05) and VAV terminal units are properly sized/selected (refer to par. C-2.11) and set up properly during commissioning, the system should be sufficiently self-balancing.

C-2.17 Use round ducts wherever space availability permits. Round ducts are acoustically superior to rectangular ducts and normally cost less. In high velocity systems, the additional friction losses of duct walls and balancing dampers of rectangular ducts cause the system to be inherently less stable. Round ducts also produce less noise than rectangular ducts.

C-2.18 To save construction expense, it is now common to serve ceiling outlets with short runs of flexible duct. Limit the length of flexible duct and avoid bends to minimize duct friction drop. Figure these pressure drops, and do not show longer runs

## APPENDIX C (Continued)

on the drawings than you allow in the specifications. Seek self-balancing by having equal lengths of flexible ducts instead of long and short runs on the same system.

When designing VAV systems, do not use flex duct upstream of the terminal VAV box (i.e., between the air handling unit and the VAV box). Use flex duct only to make terminal runs to diffuser boots and limit applications to straight runs of no more than 5 feet. Hard duct 90 degree elbows should be used to connect the flex duct to the diffuser boot. Do not use flex duct for elbows.

C-2.19 Many zones in Navy buildings do not need heating. These include zones in a building in a cooling only climate or completely interior zones in any climate. In these situations, a recommended control sequence is as follows: the air handling unit supplies a constant cold temperature (say 55 degrees F) air. Each VAV box modulates from maximum position (fully open) to minimum position (fully closed) through the control range of the room thermostat. The justification for allowing full close-off in interior zones, in light of IAQ concerns, is that the people load plus lights in an interior zone are substantial, usually amounting to 50 percent of the zone load or more. This is true for perimeter zones in a cooling only climate also, but to a lesser extent. So, if people are present, and thus the lights are on, the load will be above the minimum anyway. Therefore, the minimum is not needed. If the people are gone and the lights are out, the load may fall below where a ventilation determined limit would come into play, but since the people are gone, no ventilation is needed.

C-2.20 For zones that need heating, there are two recommended situations. For the very cold climate when the peak heating load on the exterior wall is greater than 400 Btuh per linear foot of wall (including infiltration), a separate skin heating system may be used consisting of baseboard hot water convectors. Two-position electric spring-return control valves should be installed in each zone. Thus each perimeter zone will be served by a VAV terminal unit for cooling and a corresponding section of hot water convector for heating. The zone thermostat should control both the VAV damper actuator and hot water valve actuator in sequence at the cooling and heating setpoint. The VAV damper should have a mechanical minimum position for ventilation air which would be field set during the testing and balancing phase of installation.

## APPENDIX C (Continued)

a) For a mild or moderate heating situation when the peak heating load on the exterior wall is less than 400 Btuh per linear foot of wall, the following arrangement is recommended. Each zone should be served by the series fan-powered VAV box with a hot water heating coil and overhead supply diffusers. The thermostat should modulate the VAV damper closed to the mechanically field set minimum position at the cooling setpoint. On the further drop in space temperature to the heating setpoint, the hot water valve should open (using a modulating electric spring-return actuator) to allow control of heating. An alternate arrangement uses a parallel fan-powered VAV box with heating coil. The VAV box fan motor should be started when the VAV damper closes to a supply rate of 4 air changes per hour.

b) Since the use of fan-powered boxes adds several hundred dollars per zone of first cost, the zoned baseboard heat option (described for very cold climates) may be considered, even in mild climates.

c) In perimeter zones there will be a need to setback the temperature in many buildings when there is no occupancy. This is generally accomplished by a night setback thermostat which can bring the heating system back on line to maintain the setback temperature.

C-2.21 In perimeter zones with a VAV cooling system and a separate perimeter heating system, design controls so that occupants cannot adjust thermostats for simultaneous heating and cooling. This can be done by using a thermostat with cooling and heating setpoints integrated so that ranges of possible adjustment do not overlap.

C-2.22 Systems that are to be shut down or setback during unoccupied periods can present special problems. The greatest load will occur during start-up. The supply air or coil shall be capable of bringing the temperature back to design in a reasonable time without ill effects. For instance, the designer must be careful that the temperature of supply air during start-up is not too far below the room dew point temperature to prevent condensation on diffusers.

Specify a method for building warm-up after setback. Many systems contain totally interior zones that have been designed without heat. The space, after setback over a weekend, can require an unacceptably long period of time to come up to temperature. This warm-up sequence could be accomplished by using a microprocessor-based thermostat with a built-in automatic

## APPENDIX C (Continued)

changeover. The warm-up cycle would be as follows: in the morning the air handling unit is turned on (typically by the same device that turned the unit off for setback). A central hot water coil in the AHU is activated, and the thermostats are signaled to warm-up action. During the warm-up the interior zone thermostats thus open up the air dampers to warm up the space to the thermostat setpoint. After the warm-up period, the thermostats are signaled to return to normal action for cooling and the AHU hot water coil is deactivated.

C-2.23 The designer should be aware that pneumatic damper actuators provided are often inadequately sized and are not capable of performing their specified duty. Paying special attention to submittals in this area or specifying pilot positioners could help avoid many problems.

C-2.24 Note that use of air troffer lighting return may reduce design air volume to an undesirable low air distribution level (in non-fan-powered systems).

C-2.25 Modulate the capacity of the supply fan, giving attention to the method chosen. Be aware that all of the available methods, including variable speed, inlet guide vanes, controllable pitch vane axial, and even discharge dampers, have problems in Navy VAV systems. Feedback: Inlet guide vanes are often found to be inoperable due to poor maintenance. They are not the trouble-free devices that the designers think they are. It is recommended that supply air fans under 10 horsepower be forward curved fans with inlet guide vanes. Supply fans larger than 10 horsepower should be equipped with a variable frequency drive (VFD). When designing a system with a VFD, the following guides may be of help.

C-3.00 Sequence of Operation. For suggested sequence of operations, refer to par. 8.5.

C-4.00 System Commissioning. For recommended commissioning procedures, refer to pars. 8.6 and 8.6.7 which specifically address VAV systems.

C-4.01 Operation and Maintenance Personnel Training. It is suggested that training sessions of operation and maintenance

APPENDIX D  
VARIABLE SPEED DRIVES (VFD)D-1.00 Introduction

D-1.01 Scope and Criteria. This appendix is intended to provide basic information on the principles of operation of VFD's, description of different types of VFD's, guidance on the proper application of VFD's, and installation guidelines to ensure successful operation of VFD's. Over the last few years, the VFD has become one of the most effective motor controllers available for varying the speed of squirrel-cage induction motors. VFD's save energy, reduce electrical consumption, enhance equipment performance, are highly reliable, and have become affordable. Much of the material presented in this Appendix was developed by Mr. Solomon S. Turkel, Senior Instructor and Course Author for Advanced Technologies Marketing and Service (ATMS) Inc., Baltimore, MD.

D-1.02 Terminology. VFD's drives are sometimes called adjustable frequency controllers (AFC's). It is incorrect to call them inverters or even adjustable speed drives (ASD's). The term "ASD" refers to many types of adjustable speed drives, including belt or gear drives, eddy-current clutches, variable-pitch sheave drives, and DC systems, as well as VFD's. The VFD is the only type of motor drive that controls the speed of an AC induction motor by changing the frequency and voltage appropriately. The VFD microprocessor-based motor controller incorporates an electronic control section, an electromagnetic and semiconductor power section, and typical components used with standard motor controllers. Currently, available sizes range from 1/3 horsepower (hp) to thousands of hp.

D-1.03 Operation. The principles of operation of VFD's are closely related to basic motor theory. During operation, the stator's rotating magnetic field, which is created by the AC line power to the motor, induces a voltage in the rotor. This induced voltage causes a current to flow in the rotor, which creates magnetic fields with north and south poles. The synchronous speed of an AC induction motor is dependent upon the number of poles in the stator and the frequency of the line power applied. The basic equation is as follows:

$$\text{Speed} = (120 \text{ times frequency}) \text{ divided by number of poles}$$

From this equation, a four-pole motor operating at 60 Hz will have synchronous speed of 1800 rpm. When a VFD supplies power to an AC motor, it has the capability to provide a voltage



## APPENDIX D (Continued)

at a frequency from less than 1 Hz to about 120 Hz. This means that the motor may run extremely slow or very fast, depending on the frequency supplied; and the amplitude of the voltage supplied must be proportional to the frequency to ensure the proper volts/hertz ratio for the specific motor. The output torque for a motor is determined by the ratio of voltage applied to the motor at a given frequency. Failure to maintain the proper volts-per-hertz ratio will affect motor torque, temperature, speed, noise, and current draw. Thus, for a motor to produce its rated torque at variable speeds, it is also necessary to control the voltage as well as the frequency supplied to the motor. For example, a 460 volt motor operating at 60 Hz will have a volts/hertz ratio of 7.67 to 1. For a VFD to operate this motor at 30 Hz (half speed), the motor voltage must be reduced to 230 volts to maintain the same torque characteristics for the motor. Motors are designed with specific torque characteristics and are classified accordingly. While two motors may have the same horsepower rating, their actual torque capability in the areas of breakaway torque, pull-up torque, peak torque, and full-load torque may be different, depending on their NEMA classifications. Typical designs are Type A, B, C, and D. Refer to National Electrical Manufacturers Association (NEMA) MG-1, Motors and Generators, for a detailed explanation of these NEMA designs and of motor torque capabilities. Although the motor is sized by horsepower, the required torque at all speeds is the key to successful, efficient operation of the VFD and its motor.

D-1.04 Types of VFD's. Although VFD's control the speed of an AC induction motor by varying the motor's supplied voltage and frequency of power, they do not all use the same designs in doing so. The major VFD designs commonly used at the time of publication of this handbook are:

- a) Pulse Width Modulated (PWM)
- b) Current Source Inverter (CSI)
- c) Voltage Source Inverter (VSI)
- d) Flux Vector Drive

An understanding of these different designs, along with their advantages and disadvantages will be beneficial to correctly match the VFD with the motor in a specific application.

## APPENDIX D (Continued)

D-1.04.1 PWM Design

a) The PWM drive has become the most commonly used drive controller because it works well with motors ranging in size from about 1/2 hp to 500 hp. A significant reason for its popularity is that it's highly reliable, affordable, and reflects the least amount of harmonics back into its power source. Most units are rated either 230 volts or 460 volts, three-phase, and provide output frequencies from about 2 Hz to 400 Hz. Nearly 100 manufacturers market the PWM controller.

b) In the PWM drive, an AC line supply voltage is brought into the input section. From here, the AC voltage passes into a converter section that uses a diode bridge converter and large DC capacitors to create and maintain a stable, fixed DC bus voltage. The DC voltage passes into the inverter section usually furnished with insulated gate bipolar transistors (IGBT's), which regulate both voltage and frequency to the motor to produce a near sine wave like output.

c) The term "pulse width modulation" explains how each transition of the alternating voltage output is actually a series of short pulses of varying widths. By varying the width of the pulses in each half cycle, the average power produced has a sine-like output. The number of transitions from positive to negative per second determines the actual frequency to the motor.

d) Switching speeds of the IGBT's in a PWM drive can range from 2 kHz to 15 kHz. Today's newer PWM designs use power IGBT's, which operate at these higher frequencies. By having more pulses in every half cycle, the motor whine associated with VFD applications is reduced because the motor windings are now oscillating at a frequency beyond the spectrum of human hearing. Also, the current wave shape to the motor is smoothed out as current spikes are removed.

e) PWM's have the following advantages:

(1) Excellent input power factor due to fixed DC bus voltage.

(2) No motor cogging normally found with six-step inverters.

(3) Highest efficiencies: 92 percent to 96 percent.

APPENDIX D (Continued)

- (4) Compatibility with multimotor applications.
- (5) Ability to ride through a 3 to 5 Hz power loss.
- (6) Lower initial cost.

f) The following disadvantages, however, should also be considered:

- (1) Motor heating and insulation breakdown in some applications due to high frequency switching of transistors.
- (2) Non-regenerative operation.
- (3) Line-side power harmonics (depending on the application and size of the drive).

D-1.04.2 CSI Design. In the CSI drive design, the incoming power source is converted to DC voltage in an SCR converter section, which regulates the incoming power and produces a variable DC bus voltage. This voltage is regulated by the firing of the SCR's as needed to maintain the proper volt/hertz ratio. SCR's are also used in the inverter section to produce the variable frequency output to the motor. CSI drives are inherently current regulating and require a large internal inductor to operate, as well as a motor load.

a) CSI's have the following advantages:

- (1) Reliability due to inherent current limiting operation.
- (2) Regenerative power capability.
- (3) Simple circuitry.

b) The following are disadvantages which should be considered in the use of CSI technology:

- (1) Large power harmonic generation back into the power source.
- (2) Cogging below 6 Hz due to square wave output.
- (3) Use of large and costly inductor.

## APPENDIX D (Continued)

- (4) High voltage spikes to motor windings.
- (5) Load dependent; poor for multimotor applications.
- (6) Poor input power factor due to SCR converter section.

D-1.04.3 VSI Design. The VSI drive is very similar to a CSI drive in that it also uses an SCR converter section to regulate DC bus voltage. Its inverter section produces a six-step output, but is not a current regulator like the CSI drive. This drive is considered a voltage regulator and uses transistors, SCR's, or gate turn off thyristors (GTO's) to generate an adjustable frequency output to the motor.

a) VSI's have the following advantages:

- (1) Basic simplicity in design.
- (2) Applicable to multimotor operations.
- (3) Operation not load dependent.

b) As with other types of drives, there are disadvantages:

- (1) Large power harmonic generation back into the power source.
- (2) Poor input power factor due to SCR converter section.
- (3) Cogging below 6 Hz due to square wave output.
- (4) Non-regenerative operation.

D-1.04-4 Flux Vector PWM Drives

a) PWM drive technology is still considered new and is continuously being refined with new power switching devices and smart 32-bit microprocessors. AC drives have always been limited to normal torque applications while high torque, low rpm applications have been the domain of DC drives. This has changed recently with the introduction of a new breed of PWM drive, the flux vector drive.

## APPENDIX D (Continued)

b) Flux vector drives use a method of controlling torque similar to that of DC drive systems, including wide speed control range with quick response. Flux vector drives have the same power section as PWM drives, but use a sophisticated closed loop control from the motor to the drive's microprocessor. The motor's rotor position and speed is monitored in real time via a resolver or digital encoder to determine and control the motor's actual speed, torque, and power produced.

c) By controlling the inverter section in response to actual load conditions at the motor in a real time mode, superior torque control can be obtained. The personality of the motor must be programmed into or learned by the drive in order for it to run the vector control algorithms. In most cases, special motors are required due to the torque demands expected of the motor.

d) The following are advantages of this new drive technology:

- (1) Excellent control of motor speed, torque, and power.
- (2) Quick response to changes in load, speed, and torque commands.
- (3) Ability to provide 100 percent rated torque at zero speed.
- (4) Lower maintenance cost as compared to DC motors and drives.

e) The following are disadvantages:

- (1) Higher initial cost as compared to standard PWM drives.
- (2) Requires special motor in most cases.
- (3) Drive setup parameters are complex.

While flux vector technology offers superior performance for certain special applications, it would be considered "overkill" for most applications well served by standard PWM drives.

D-1.05 Application of VFD's to Specific Loads. VFD's are the most effective energy savers in pump and fan applications, and

## APPENDIX D (Continued)

they enhance process operations, particularly where flow control is involved. VFD's soft start capabilities decrease electrical stresses and line voltage sags associated with full voltage motor start-ups, especially when driving high-inertia loads. For the motor to produce the required torque for the load, the VFD must have ample current capability to drive the motor. It is important to note that machine torque is independent of motor speed and that load horsepower increases linearly with rpm. Individual load types are as follows:

a) Constant torque loads. Constant torque loads represent 90 percent of general industrial machines (other than pumps and fans). Examples of these load types include general machinery, hoists, conveyors, printing presses, positive displacement pumps, some mixers and extruders, reciprocating compressors, as well as rotary compressors.

b) Constant horsepower loads. Constant horsepower loads are most often found in the machine tool industry and center driven winder applications. Examples of constant horsepower loads include winders, core-driven reels, wheel grinders, large driller machines, lathes, planers, boring machines, and core extruders.

Traditionally, these loads were considered DC drive applications only. With high performance flux vector VFD's now available, many DC drive applications of this type can be now handled by VFD's.

c) Variable torque loads. Variable torque loads are most often found in variable flow applications, such as fans and pumps. Examples of applications include fans, centrifugal blowers, centrifugal pumps, propeller pumps, turbine pumps, agitators, and axial compressors. VFD's offer the greatest opportunity for energy savings when driving these loads because horsepower varies as the cube of speed and torque varies as square of speed for these loads. For example, if the motor speed is reduced 20 percent, motor horsepower is reduced by a cubic relationship (.8 x .8 x .8), or 51 percent. As such, utilities often offer subsidies to customers investing in VFD technology for their applications. Many VFD manufacturers have free software programs available for customers to calculate and document potential energy savings by using VFD's.

D-1.06 Special Applications of VFD's. If any of the following operations apply, use extra care in selecting a VFD and its setup parameters.

## APPENDIX D (Continued)

a) VFD operating more than one motor. The total peak currents of motor loads under worst operating conditions must be calculated. The VFD must be sized based on this maximum current requirement. Additionally, individual motor protection must be provided here for each motor.

b) Load is spinning or coasting when the VFD is started. This is very often the case with fan applications. When a VFD is first started, it begins to operate at a low frequency and voltage and gradually ramps up to a preset speed. If the load is already in motion, it will be out of sync with the VFD. The VFD will attempt to pull the motor down to the lower frequency, which may require high current levels, usually causing an overcurrent trip. Because of this, VFD manufacturers offer drives with an option for synchronization with a spinning load; this VFD ramps at a different frequency.

c) Power supply source is switched while the VFD is running. This occurs in many buildings, such as hospitals, where loads are switched to standby generators in the event of a power outage. Some drives will ride through a brief power outage while others may not. If your application is of this type, it must be reviewed with the drive manufacturer for a final determination of drive capability.

d) Hard to start load. These are the motors that dim the lights in the building when you hit the start button.

Remember, the VFD is limited in the amount of overcurrent it can produce for a given period of time. These applications may require oversizing of the VFD for higher current demands.

e) Critical starting or stopping times. Some applications may require quick starting or emergency stopping of the load. In either case, high currents will be required of the drive. Again, oversizing of the VFD may be required.

f) External motor disconnects required between the motor and the VFD. Service disconnects at motor loads are very often used for maintenance purposes. Normally, removing a load from a VFD while operating does not pose a problem for the VFD. On the other hand, introducing a load to a VFD by closing a motor disconnect while the VFD is operational can be fatal to the VFD. When a motor is started at full voltage, as would happen in this case, high currents are generated, usually about six times the full load amperes of the motor current. The VFD would see these

## APPENDIX D (Continued)

high currents as being well beyond its capabilities and would go into a protective trip or fail altogether. A simple solution for this condition is to interlock the VFD run permissive circuit with the service disconnects via an auxiliary contact at the service disconnect. When the disconnect is closed, a permissive run signal restarts the VFD at low voltage and frequency.

g) Power factor correction capacitors being switched or existing on the intended motor loads. Switching of power factor capacitors usually generates power disturbances in the distribution system. Many VFD's can and will be affected by this. Isolation transformers or line reactors may be required for these applications.

Power factor correction at VFD-powered motor loads is not necessary as the VFD itself does this by using DC internally and then inverting it into an AC output to the motor. VFD manufacturers warn against installing capacitors at the VFD output.

D-1.07 Sizing VFD's for the Load. To properly size a VFD for an application, you must understand the requirements of the load. The torque ratings are as important as the horsepower ratings. Every load has distinct torque requirements that vary with the load's operation; these torques must be supplied by the motor via the VFD. You must have a clear understanding of these torques.

a) Breakaway torque: torque required to start a load in motion (typically greater than the torque required to maintain motion).

b) Accelerating torque: torque required to bring the load to operating speed within a given time.

c) Running torque: torque required to keep the load moving at all speeds.

d) Peak torque: occasional peak torque required by the load, such as a load being dropped on a conveyor.

e) Holding torque: torque required by the motor when operating as a brake, such as down hill loads and high inertia machines.

D-1.08 Guidelines for Matching VFD to Motor. The following guidelines will help ensure a correct match of VFD and motor:



## APPENDIX D (Continued)

a) Define the operating profile of the load to which the VFD is to be applied. Include any or all of the torques listed in par. D-1.07. Using a recording true rms ammeter to record the motor's current draw under all operating conditions will help in doing this. Obtain the highest "peak" current readings under the worst conditions. Also, see if the motor has been working in an overloaded condition by checking the motor full-load amperes (FLA). An overloaded motor operating at reduced speeds may not survive the increased temperatures as a result of the reduced cooling effects of the motor at these lower speeds.

b) Determine why the load operation needs to be changed. Very often VFD's have been applied to applications where all that was required was a "soft start" reduced voltage controller. The need for the VFD should be based on the ability to change the load's speed as required. In those applications where only one speed change is required, a VFD may not be necessary or practical.

c) Size the VFD to the motor based on the maximum current requirements under peak torque demands. Do not size the VFD based on horsepower ratings. Many applications have failed because of this. Remember, the maximum demands placed on the motor by the load must also be met by the VFD.

d) Evaluate the possibility of required oversizing of the VFD. Be aware that motor performance (breakaway torque, for example) is based upon the capability of the VFD used and the amount of current it can produce. Depending on the type of load and duty cycle expected, oversizing of the VFD may be required.

D-1.09 Key VFD Specification Parameters. The most important information to be included in a VFD specification are continuous current rating, overload current rating, and line voltage of operation.

a) Continuous run current rating. This is the maximum rms current the VFD can safely handle under all operating conditions at a fixed ambient temperature (usually 40 degrees C). Motor full load sine wave currents must be equal to or less than this rating.

b) Overload current rating. This is an inverse time/current rating that is the maximum current the VFD can produce for a given time frame. Typical ratings are 110 percent to 150 percent overcurrent for 1 minute, depending on the

## APPENDIX D (Continued)

manufacturer. Higher current ratings can be obtained by oversizing the VFD. This rating is very important when sizing the VFD for the currents needed by the motor for breakaway torque.

c) Line voltage. As with any motor controller, an operating voltage must be specified. VFD's are designed to operate at some nominal voltage such as 240 volts AC or 480 volts AC, with an allowable voltage variation of plus or minus 10 percent. Most motor starters will operate beyond this 10 percent variation, but VFD's will not and will go into a protective trip. A recorded voltage reading of line power deviations is highly recommended for each application.

d) Additional considerations. The following information is helpful when applying drives and should be included and verified prior to selection of a drive:

- (1) Starting torque currents
- (2) Running torque currents
- (3) Peak loading currents
- (4) Duty cycle
- (5) Load type
- (6) Speed precision required
- (7) Performance (response)
- (8) Line voltages (deviations)
- (9) Altitude
- (10) Ambient temperature
- (11) Environment
- (12) Motoring/regenerating load
- (13) Stopping requirements
- (14) Motor nameplate data
- (15) Input signals required

## APPENDIX D (Continued)

## (16) Output signals required

D-1.10 VFD Installation and Start-Up. Over half of drive failures are a result of improper installation and start-up. Careful planning of your VFD installation will help avoid many problems. Be sure the VFD specification requires furnishing of the drive's operation and maintenance manual. Important considerations include temperature and line power quality requirements, along with electrical connections, grounding, fault protection, motor protection, and environmental parameters.

a) Temperature. Equipment should be located in areas which are well within manufacturer's specified temperature limits and are well ventilated to remove generated heat. Avoid installing units in mezzanines, direct sunlight, or near external heat sources to avoid unpredictable temperature rises. Provide supplemental cooling if these areas cannot be avoided.

b) Supply Line Power Quality. The line voltage to the drive input should vary no more than plus or minus 10 percent to avoid tripping the unit via a protective fault. Voltage drop calculations must take this into account when running conductors long distances from the power source.

c) Electrical Connections. Size VFD line and load conductors to conform to NFPA 70.

d) Grounding. In addition to running a grounding conductor back to the electrical service entrance, bring a grounding conductor back from the motor to the VFD's internal grounding terminal. This direct motor ground to the VFD is required to minimize interference and for proper operation of the ground-fault protection function.

e) Fault Protection. Many VFD's have short-circuit protection (usually in the form of fuses) already installed by the manufacturer. This is usually the case on larger horsepower units. Smaller units (1/3 to 5 hp) normally require external fuse protection. In either case, the selection and sizing of these fuses is critical for semiconductor protection in the event of a fault. The manufacturer's recommendations must be followed when installing or replacing fuses for the VFD. Be sure to torque-bolt fuses in place according to the manufacturer's specification to ensure fast operation of fuses in case of a fault.

## APPENDIX D (Continued)

f) Motor Protection. Motors require overload protection. The most common practice is the use of a motor overcurrent relay system that will protect all three phases and protect against single-phasing. This type of protection will respond to motor overcurrent conditions of an overloaded motor, but will not detect overtemperature conditions.

A motor operating at reduced speeds will have reduced cooling; as a result, it may fail due to thermal breakdown of the motor windings insulation. Thus, the optimum protection for a motor is thermal sensing of the motor windings. This sensing is then interlocked with the VFD's control circuit. This is highly recommended for any motor that is to be operated for extended periods of time at low speeds.

## g) Environment

(1) Humidity and Moisture. As is the case with all electrical and electronic equipment, high humidity and corrosive atmospheres are a concern. Drive units should be installed in a noncorrosive location whenever possible, with ambient humidity ranging between 0 to 95 percent noncondensing. Avoid locations subject to rain, dust, corrosive fumes, or vapors, and salt water. In some cases, appropriate NEMA enclosures may be specified where some of these locations cannot be avoided. Consult VFD manufacturers about the location and application before doing so.

(2) Vibration. Do not locate VFD's near vibrating equipment unless appropriate vibration isolation methods are employed.

(3) Line Transmitted Transients. The VFD is a solid-state electronic device, therefore, surge and transient protection (from lightning strikes, circuit switching, large motor starting, etc.) should be specified, either integral to the VFD or external, as appropriate.

D-1.11 Start-Up Procedures

a) Successful installation of VFD's, as with nearly all electrical equipment, is derived from an orderly, well planned start-up procedure. After reading the entire VFD manual and before energizing the VFD, make a physical inspection of the VFD and look for the following:

APPENDIX D (Continued)

(1) Any moisture or debris (metal shavings for example) inside the equipment.

(2) Damage or dents to the enclosure, damaged or loose components and wires, and disconnected terminal connectors.

(3) Possible restrictions to airflow at the cooling fans or heat sink.

(4) Unremoved shipping blocks or tapes at power contactors, relays, etc.

b) In addition to the VFD itself, you should also make a visual inspection of the entire system, including motors, disconnect switches, circuit breakers, controls, load components, control devices (limit, float, pressure switches, etc.).

c) Finally, you should make an intense and thorough check of the following items:

(1) Connections (line, load, and ground).

(2) Motor (horsepower, full-load amperes, voltage, and rotation).

(3) VFD (input/output voltages, maximum output current).

(4) Protective devices (circuit breaker, fuses, overloads, thermal devices).

(5) Disconnects (are they in place and sized correctly?).

(6) Incoming line power voltage measurements to the VFD (A-B phase, B-C phase, C-A phase).

d) It is recommended that you use a VFD start-up guide sheet/report in your start-up procedure. Make the report part of the project's contractual requirements within the specification section covering the VFD. The benefits of using such a report includes verifying key parameters prior to start-up, documenting the installation for warranty claims, and aiding in troubleshooting for future problems. The following instruments should be available at the VFD location for start-up:

APPENDIX D (Continued)

(1) True rms multimeter capable of reading AC/DC voltages up to 750 volts.

(2) True rms clamp-on ammeter capable of reading the VFD's maximum current output.

(3) Photo tachometer to verify shaft output speed at load.

(4) Current/voltage signal generator to generate a reference analog signal to VFD (4 to 20 milliamperes or 0 to 5 volts). (This is extremely useful on HVAC applications where the building automation system designed to control the VFD is not ready at time of start-up.)

(5) Oscilloscope to check wave shapes of VFD output to motor. These wave shapes can be compared to those provided in the start-up manual, or recorded (via Polaroid camera) for future comparison during troubleshooting or maintenance. The scope also can be used to check volts/hertz ratio.

e) Make up a complete final check, via a check-off list, of electrical and mechanical components to be sure that they are set correctly. This includes valves, dampers, limit switches, steady-state voltage, and current valves.

f) Station people at key locations (motor, controller panel, load(s), etc.).

g) A proper start-up can be considered complete only when the VFD is operated at full load. This is important because you then can make meaningful drive adjustments. You can verify this by actually checking the FLA and comparing the value to that on the motor nameplate.

h) When the start-up command is given, watch, listen, and smell for anything unusual. Once start-up has been accomplished, allow the system to run a few hours before taking test readings for future comparison.

D-1.12 VFD Generated EMI and Harmonic Distortion Concerns.

Harmonics are generated by nonlinear devices which rectify the incoming AC voltage to DC and then invert it back to AC, as is the case with a VFD running a motor. Harmonics from nonlinear devices are odd multiples of the fundamental frequency (third, fifth, seventh, etc.). Some parts of the electrical distribution

## APPENDIX D (Continued)

system designed for 60 Hz can have significant losses at harmonic frequencies, which causes higher operating temperatures and shortened component life. The harmonics generated by a VFD affect not only the load it serves (the motor), but are also reflected back into the power distribution system, thus affecting other devices connected to the distribution system. Reference 13 addresses the motor heating and life expectancy concerns. The physical location of the VFD and its interface point with the power system within the facility are important. Do not locate the VFD near other electronic equipment, including radar equipment, radio equipment, computers, hospital diagnostic and life support equipment, or telecommunications equipment. Minimize the length of line and load power leads as much as possible. Always run line and load conductors in a grounded continuous metallic conduit system. Since most mechanical systems and controls now include solid-state electronics, take precautions to prevent their damage or malfunction due to VFD generated harmonics. Filters can be added to the VFD input circuit when the VFD does not include adequate filtering internally for the specific application. Consult the electrical design engineer for help with resolving interference and harmonic distortion concerns.

D-1.13 VFD-Driven Premium Efficiency Motor Concerns. Although beyond the scope of this handbook, it should be noted that not all premium efficiency motors are suitable for control by VFD's. During the design stage, contact both VFD manufacturers and premium efficiency motor manufacturers to ensure compatibility for the application at hand.

D-1.14 Troubleshooting VFD Problems. Although important in ensuring long-term successful VFD operation, it is beyond the scope of this handbook to cover troubleshooting of VFD problems. The subject of troubleshooting VFD's during their operating lifetime is well covered in References 6 and 7.

## REFERENCES

1. Understanding Variable Speed Drives - Part 1, S. S. Turkel, Electrical Construction and Maintenance (EC&M), February 1995.
2. Understanding Variable Speed Drives - Part 2, S. S. Turkel, EC&M, March 1995.
3. Understanding Variable Speed Drives - Part 3, S. S. Turkel, EC&M, April 1995.

APPENDIX D (Continued)

4. Understanding Variable Speed Drives - Part 4, S. S. Turkel, EC&M, May 1995.
5. Understanding Variable Speed Drives - Part 5, S. S. Turkel, EC&M, June 1995.
6. Understanding Variable Speed Drives - Part 6, S. S. Turkel, EC&M, July 1995.
7. Troubleshooting Variable Speed Drives, S. S. Turkel, EC&M, May 1995.
8. Understanding Modern Motors and Controllers, R. J. Lawrie, EC&M, March 1995.
9. Pumping for Dollars, D. W. Kelly, Consulting- Specifying Engineer, August 1995.
10. NEMA ICS 3.1-90, Safety Standards for Construction and Guide for Selection, Installation and Operation of Adjustable-Speed Drive Systems.
11. NEMA ICS 7-93, Industrial Control and Systems - Adjustable-Speed Drives.
12. IEEE 519-92, IEEE Recommended Practice and Requirements for Harmonic Control in Electrical Power Systems.
13. The Impact of Adjustable Speed Drives on AC Induction Motor Heating, Efficiency, and Life Expectancy, H. T. Maase and R. Rundus, U.S. Army CERL, Champaign, IL, presented at 1995 USACE Electrical and Mechanical Engineering Training Conference, June 5-9, 1995, St. Louis, MO.



APPENDIX D (Continued)

VFD Start-Up Report

Report No.: \_\_\_\_\_  
Report Date: \_\_\_\_\_

Customer: \_\_\_\_\_

Contact Name: \_\_\_\_\_ Phone Number: \_\_\_\_\_

Address: \_\_\_\_\_

City/Base: \_\_\_\_\_ State/Country: \_\_\_\_\_ Zip: \_\_\_\_\_  
.....

Equipment Manufacturer: \_\_\_\_\_ Model No.: \_\_\_\_\_

Equipment Location: \_\_\_\_\_ Serial No.: \_\_\_\_\_

List of Options: \_\_\_\_\_  
\_\_\_\_\_

Installation Notes: \_\_\_\_\_  
\_\_\_\_\_

Type of Load: \_\_\_\_\_ Load Location: \_\_\_\_\_  
.....

Motor Manufacturer: \_\_\_\_\_ Horsepower: \_\_\_\_ Service Factor: \_\_\_\_

Voltage: \_\_\_\_\_ RPM: \_\_\_\_\_ Frequency: \_\_\_\_\_ Frame: \_\_\_\_\_

Current: \_\_\_\_\_ Insulation Class: \_\_\_\_\_ NEMA Class: \_\_\_\_\_

Load Rotation: \_\_\_\_\_ Overload Heater Size: \_\_\_\_\_  
.....

Installation Inspection

Clearances - Front: \_\_ Back: \_\_ Left: \_\_ Right: \_\_ Bottom: \_\_

Grounding Method: \_\_\_\_\_ Ground Wire Size: \_\_\_\_\_

Isolation Transformer (Y/N): \_\_\_\_ Motor Disconnects (Y/N): \_\_\_\_

Details for Yes Answers: \_\_\_\_\_  
\_\_\_\_\_

Ambient Temperature: \_\_\_\_\_ Exposure: \_\_\_\_\_

APPENDIX D (Continued)

Electrical Inspection

Incoming Voltages - A-B Phase: \_\_\_ B-C Phase: \_\_\_ C-A Phase: \_\_\_

A-Neutral: \_\_\_\_\_ B-Neutral: \_\_\_\_\_ C-Neutral: \_\_\_\_\_

External Control Voltages (source): \_\_\_\_\_ Fused: \_\_\_\_\_

External Process Signals (4-20 mA, 3-15 psi, 0-10 vdc, 0-250 ohm): \_\_\_\_\_

Process Signal Sources: \_\_\_\_\_

.....

Set Up Parameters

Accel Time (sec): \_\_\_ Decel Time (sec): \_\_\_ Second Accel/Decel: \_\_\_

Auto Restart (Y/N): \_\_\_ Multiple Attempt Restart (Y/N): \_\_\_\_\_

Maximum Speed: \_\_\_ Minimum Speed: \_\_\_ Extended Freq. (Y/N): \_\_\_

Torque Boost (level): \_\_\_\_\_ Gain: \_\_\_\_\_ Offset: \_\_\_\_\_

Set Up Notes: \_\_\_\_\_

\_\_\_\_\_

.....

Operational Parameters

	Inverter	Bypass
Line Current	A Phase: _____	A Phase: _____
	B Phase: _____	B Phase: _____
	C Phase: _____	C Phase: _____

Load Current	A Phase: _____	A Phase: _____
	B Phase: _____	B Phase: _____
	C Phase: _____	C Phase: _____

DC Bus Voltage: \_\_\_ Heat Sink Temperature (1 hr run time): \_\_\_\_\_

Frequency Output at 0 % Reference Signal: \_\_\_\_\_

Frequency Output at 100% Reference Signal: \_\_\_\_\_

Start Up Complete (Y/N): \_\_\_ Completion Date: \_\_\_\_\_

Start Up Completed By: \_\_\_\_\_

Remarks: \_\_\_\_\_

## REFERENCES

NOTE: THE FOLLOWING REFERENCED DOCUMENTS FORM A PART OF THIS HANDBOOK TO THE EXTENT SPECIFIED HEREIN. USERS OF THIS HANDBOOK SHOULD REFER TO THE LATEST REVISIONS OF CITED DOCUMENTS UNLESS OTHERWISE DIRECTED.

FEDERAL/MILITARY SPECIFICATIONS AND STANDARDS, BULLETINS, HANDBOOKS, DESIGN MANUALS, AND NAVFAC GUIDE SPECIFICATIONS:

Unless otherwise indicated, copies are available from the Naval Publishing and Printing Service Office (NPPSO), Standardization Document Order Desk, Building 4D, 700 Robbins Avenue, Philadelphia, PA 19111-5094.

## STANDARDS

MIL-STD-1691	Construction and Material Schedule for Military Medical and Dental Facilities.
--------------	--

## HANDBOOKS

MIL-HDBK-423	High-Altitude Electromagnetic Pulse (HEMP) Protection for Fixed and Transportable Ground-Based Facilities <sup>C4I</sup>
MIL-HDBK-1003/6	Central Heating Plants
MIL-HDBK-1003/8A	Exterior Distribution of Utility Steam, High Temperature Water (HTW), Chilled Water, Natural Gas and Compressed Air
MIL-HDBK-1003/17	Industrial Ventilation Systems
MIL-HDBK-1004/10	Electrical Engineering Cathodic Protection
MIL-HDBK-1008B	Fire Protection for Facilities Engineering, Design, and Construction
MIL-HDBK-1011/1	Tropical Engineering
MIL-HDBK-1035	Family Housing

MIL-HDBK-1003/3

MIL-HDBK-1036	Bachelor Quarters
MIL-HDBK-1190	Facility Planning and Design Guide
MIL-HDBK-1191	Medical and Dental Treatment Facilities Design and Construction Criteria

DESIGN MANUALS

DM-3.01	Plumbing Systems
---------	------------------

SPECIFICATIONS

NFGS-15250	Mechanical Insulation
NFGS-15652	Central Refrigeration Equipment for Air Conditioning
NFGS-15895	Ductwork and Ductwork Accessories
NFGS-15971	Space Temperature Control Systems
NFGS-15972	Direct Digital Control Systems

NAVFAC P-PUBLICATIONS AND MAINTENANCE AND OPERATION MANUALS:

Unless otherwise indicated, copies are available from the Naval Publishing and Printing Service Office (NPPSO), Standardization Document Order Desk, Building 4D, 700 Robbins Avenue, Philadelphia, PA 19111-5094.

P-PUBLICATIONS

P-89	Engineering Weather Data
------	--------------------------

MAINTENANCE AND OPERATION (MO) MANUALS

MO-209	Maintenance of Steam, Hot Water, and Distribution Systems
MO-220	Maintenance and Operation of Gas Systems
MO-230	Maintenance Manual Petroleum Fuel Facilities

OTHER GOVERNMENT DOCUMENTS AND PUBLICATIONS:

10 CFR Part 435	Energy Conservation Voluntary Performance Standards for Commercial and Multi-Family High Rise Residential Buildings, Mandatory for New Federal Buildings
29 CFR Part 1910	Occupational Industry Safety and Health Standards.
OPNAVINST 5100.23	Navy Occupational Safety and Health (NAVOSH) Program Manual.
DODINST 6055.12	DOD Hearing Conservation Program

(Unless otherwise indicated, copies are available from the Naval Publishing and Printing Service Office (NPPSO), Standardization Document Order Desk, Building 4D, 700 Robbins Avenue, Philadelphia, PA 19111-5094; private organizations may purchase documents from the Superintendent of Documents, U.S. Government Printing Office, Washington, DC 20402.)

U.S. ARMY CORPS OF ENGINEERS:

	Architectural and Engineering Instructions, Design Criteria
CEGS-15950	Heating, Ventilating, and Air Conditioning (HVAC) Control Systems
ETL 94-2	Utility Meters in New and Renovated Facilities
TM 5-805-4	Noise and Vibration Control for Mechanical Equipment
TM 5-815-2	Energy Monitoring and Control Systems (EMCS)

(Unless otherwise indicated, copies are available from the Naval Publishing and Printing Service Office (NPPSO), Standardization Document Order Desk, Building 4D, 700 Robbins Avenue, Philadelphia, PA 19111-5094; private organizations may purchase documents from the Superintendent of Documents, U.S. Government Printing Office, Washington, DC 20402.)

NON-GOVERNMENT PUBLICATIONS:

AMERICAN CONFERENCE OF GOVERNMENTAL INDUSTRIAL HYGIENISTS (ACGIH)

Industrial Ventilation - Manual of  
Recommended Practice

(Unless otherwise indicated, copies are available from American  
Conference of Governmental Industrial Hygienists (ACGIH), 6500  
Glenway Avenue, Bldg. D-7, Cincinnati, OH 45211-4438.)

AMERICAN MOVEMENT AND CONTROL ASSOCIATION (AMCA)

AMCA 201 Fans and Systems

(Unless otherwise indicated, copies are available from American  
Movement and Control Association (AMCA), 30 West University  
Drive, Arlington Heights, IL 60004.)

AMERICAN SOCIETY OF HEATING, REFRIGERATING, AND  
AIR-CONDITIONING ENGINEERS, INC. (ASHRAE)

ASHRAE Equipment Handbook

ASHRAE Handbook, Fundamentals

ASHRAE Handbook, Design of Smoke Control  
Systems

ASHRAE Handbook, HVAC Systems and  
Applications

ASHRAE Handbook, Refrigeration

ASHRAE Guideline 1 Commissioning of HVAC Systems

ASHRAE STD 15 Safety Code for Mechanical Refrigeration

ASHRAE STD 62 Ventilation for Acceptable Indoor  
Air Quality

ASHRAE STD 90.1 Energy Efficient Design of New Buildings  
Except Low-Rise Residential Buildings

(Unless otherwise indicated, copies are available from the  
American Society of Heating, Refrigerating, and Air-Conditioning  
Engineers, Inc. (ASHRAE), 1791 Tullie Circle, N.E., Atlanta, GA  
30329-2305.)

NATIONAL ELECTRICAL MANUFACTURERS ASSOCIATION (NEMA)

NEMA MG-1                      Motors and Generators

(Unless otherwise indicated, copies are available from National Electrical Manufacturers Association (NEMA), 2101 L Street, N.W., Suite 300, Washington, DC 20037.)

NATIONAL FIRE PROTECTION ASSOCIATION (NFPA)

NFPA 70                          National Electrical Code

NFPA 90A                        Standard for the Installation of Air Conditioning and Ventilating Systems

NFPA 90B                        Standard for the Installation of Warm Air Heating and Air Conditioning Systems

(Unless otherwise indicated, copies are available from the National Fire Protection Association (NFPA), One Batterymarch Park, P.O. Box 9101, Quincy, MA 02269-9101.)

UNDERWRITERS LABORATORIES, INC. (UL)

UL 555S                          Standard for Safety Leakage Rated Dampers for Use in Smoke Control Systems

(Unless otherwise indicated, copies are available from Underwriters Laboratories, Inc. (UL), 333 Pfingsten Road, Northbrook, IL 60062.)

## GLOSSARY

ACGIH. American Conference of Governmental Industrial Hygienists.

ADP. Automated data processing.

AFC. Adjustable frequency controller.

ASD. Adjustable speed drive.

ASHRAE. American Society of Heating, Refrigerating, and Air-Conditioning Engineers, Inc.

ASME. American Society of Mechanical Engineers.

ATMS. Advanced Technologies Marketing and Service.

BLAST. Building loads analysis and system thermodynamics.

CFR. Code of Federal Regulations.

CSI. Current source inverter.

Cv. Control valve flow coefficient.

DDC. Direct digital controls.

DM. Design manual.

EFA. Engineering field activity.

EFD. Engineering field division.

EMCS. Energy monitoring and control system.

EOD. Explosive ordnance disposal.

ETL. Engineering technical letter.

FLA. Full-load amperes.

FMF. Fleet Marine Force.

GTO. Gate turn off thyristors.

GWP. Global warning potential.

HEPA. High efficiency air.



HVAC. Heating, ventilating, and air conditioning.

IAQ. Indoor air quality.

IGBT. Insulated bipolar transistor.

IV. Industrial ventilation.

MILCON. Military construction.

NAVFACENGCOM. Naval Facilities Engineering Command.

NEMA. National Electrical Manufacturers Association.

NFESC. Naval Facilities Engineering Service Center.

NFGS. Naval facilities guide specification.

NFPA. National Fire Protection Association.

NPSH. Net positive suction head.

ODP. Ozone depletion potential.

PC. Personal controller.

PD. Pressure dependent.

PI. Pressure independent.

PID. Proportional, integral, and derivative.

PL. Project leader.

PVC. Polyvinyl chloride.

PWM. Pulse width modulated.

SMACNA. Sheet Metal and Air Conditioning Contractors' National Association, Inc.

TM. Technical manual.

UL. Underwriters Laboratories, Inc.

UPS. Uninterrupted power supply.

VAV. Variable air volume.

VFD. Variable frequency drive.

VSI. Voltage source inverter.

VVI. Variable voltage inverter.

CUSTODIAN  
PREPARING ACTIVITY  
NAVY - YD

NAVY - YD

PROJECT NO.  
FACR-1134