

UNIFIED FACILITIES CRITERIA (UFC)

Design: Interior and Exterior Lighting and Controls



APPROVED FOR PUBLIC RELEASE; DISTRIBUTION UNLIMITED

UNIFIED FACILITIES CRITERIA (UFC)

DESIGN: INTERIOR AND EXTERIOR LIGHTING AND CONTROLS

Any copyrighted material included in this UFC is identified at its point of use. Use of the copyrighted material apart from this UFC must have the permission of the copyright holder.

U.S. ARMY CORPS OF ENGINEERS

NAVAL FACILITIES ENGINEERING COMMAND (Preparing Activity)

AIR FORCE CIVIL ENGINEER SUPPORT AGENCY

Record of Changes (changes are indicated by \1\ ... /1/)

Change No.	Date	Location

**This UFC supersedes UFC 3-530-01AN, dated September 19, 2005.
The format of Chapters 6 and 7 do not conform to UFC 1-300-01. These chapters are graphical in nature and intended as application design guidelines.**

FOREWORD

The Unified Facilities Criteria (UFC) system is prescribed by MIL-STD 3007 and provides planning, design, construction, sustainment, restoration, and modernization criteria, and applies to the Military Departments, the Defense Agencies, and the DoD Field Activities in accordance with [USD\(AT&L\) Memorandum](#) dated 29 May 2002. UFC will be used for all DoD projects and work for other customers where appropriate. All construction outside of the United States is also governed by Status of Forces Agreements (SOFA), Host Nation Funded Construction Agreements (HNFA), and in some instances, Bilateral Infrastructure Agreements (BIA.) Therefore, the acquisition team must ensure compliance with the more stringent of the UFC, the SOFA, the HNFA, and the BIA, as applicable.

UFC are living documents and will be periodically reviewed, updated, and made available to users as part of the Services' responsibility for providing technical criteria for military construction. Headquarters, U.S. Army Corps of Engineers (HQUSACE), Naval Facilities Engineering Command (NAVFAC), and Air Force Civil Engineer Support Agency (AFCESA) are responsible for administration of the UFC system. Defense agencies should contact the preparing service for document interpretation and improvements. Technical content of UFC is the responsibility of the cognizant DoD working group. Recommended changes with supporting rationale should be sent to the respective service proponent office by the following electronic form: [Criteria Change Request \(CCR\)](#). The form is also accessible from the Internet sites listed below.

UFC are effective upon issuance and are distributed only in electronic media from the following source:

- Whole Building Design Guide web site <http://dod.wbdg.org/>.

Hard copies of UFC printed from electronic media should be checked against the current electronic version prior to use to ensure that they are current.

AUTHORIZED BY:



DONALD L. BASHAM, P.E.
Chief, Engineering and Construction
U.S. Army Corps of Engineers



DR. JAMES W. WRIGHT, P.E.
Chief Engineer
Naval Facilities Engineering Command



KATHLEEN I. FERGUSON, P.E.
The Deputy Civil Engineer
DCS/Installations & Logistics
Department of the Air Force



Dr. GERT W. MOY, P.E.
Director, Installations Requirements and
Management
Office of the Deputy Under Secretary of Defense
(Installations and Environment)

Unified Facilities Criteria (UFC)
New Document Summary Sheet

Subject: UFC-3-530-01, *Design: Interior, Exterior Lighting and Controls*

Description of Change: UFC-3-530-01 is a new Unified Facilities Criteria document that describes the criteria necessary to create effective and efficient lighting designs for the wide variety of DoD facilities. It also educates facility designers and managers on emerging technologies that promise to further reduce the energy consumption of buildings.

Reasons for Change: In 2000, the Illuminating Engineering Society of North America (IESNA) published the ninth edition of the *Lighting Handbook*. This edition significantly altered the lighting recommendations by including a Lighting Design Guide. This matrix addresses the many lighting issues such as glare and uniformity that must be considered (in addition to illuminance) to provide a comfortably lighted environment.

In addition, Navy and Air Force facilities follow the US Green Building Council's LEED™ rating system and the Army uses the Sustainable Project Rating Tool (SPiRiT). Due to the large amount of energy consumed by electric lighting in buildings, improving lighting efficiency and effectiveness contributes significantly to these goals.

UFC 3-530-01:

- ❑ Updates the illuminance-based criteria to Quality of the Visual Environment per current IESNA standards.
- ❑ Includes daylighting as an important light source.
- ❑ Updates equipment recommendations for lamps and ballasts to incorporate higher performance standards.

Impact: Improving the lighting quality of workspaces and reducing the energy requirements of the lighting system both result in significant economic benefits. The Light Right Consortium research found that indirect lighting strategies that light the walls and ceiling were rated as more comfortable by office occupants. Additionally, certain dimming strategies improved the workers motivation and accuracy on office tasks. Efficient lighting design not only reduces the electricity consumption for producing light, but also significantly reduces the cooling load that must be handled by the building's mechanical system. Combining economic benefits of improved productivity and workforce satisfaction with those of energy savings from efficient sources and strategies make lighting quality an attractive investment.

UFC 3-530-01:

- ❑ Integrates occupancy and daylight lighting controls to reduce energy use.
- ❑ Emphasizes "effective" lighting strategies that can result in energy savings for lighting of between 25 to 40 percent, according to research conducted by the Federal Energy Management Program (FEMP).

CONTENTS

	<u>Page</u>
CHAPTER 1 INTRODUCTION	
Paragraph 1-1	PURPOSE AND SCOPE 1-1
1-2	APPLICABILITY 1-1
1-3	REFERENCES 1-1
CHAPTER 2 LIGHTING DESIGN CONSIDERATIONS	
Paragraph 2-1	INTRODUCTION 2-1
2-2	VISIBILITY 2-1
2-3	GLARE 2-2
2-4	UNIFORMITY 2-5
2-5	ILLUMINANCE 2-6
2-6	SURFACE BRIGHTNESS 2-8
2-7	AMBIENT/TASK/ACCENT SYSTEMS 2-10
2-8	LIGHTING CONTROL 2-10
2-9	SUSTAINABILITY ISSUES 2-12
2-10	SECURITY 2-13
2-11	MAINTENANCE ISSUES 2-13
CHAPTER 3 SUSTAINABILITY ISSUES	
Paragraph 3-1	INTRODUCTION 3-1
3-2	BUILDING RATING SYSTEMS 3-1
3-3	COSTS/BENEFITS 3-3
3-4	UTILIZING DAYLIGHT 3-4
3-5	LOW ENERGY USE 3-4
3-6	MATERIAL ISSUES 3-5
3-7	LIGHT POLLUTION 3-5
3-8	LIGHT TRESPASS 3-7
3-9	ECONOMIC ISSUES 3-8
3-10	RETROFITTING 3-8
CHAPTER 4 DAYLIGHTING	
4-1	BENEFITS OF DAYLIGHT 4-1
4-2	PROJECT TYPES THAT BENEFIT FROM DAYLIGHT 4-1
4-3	DAYLIGHTING ECONOMICS 4-1
4-4	SYSTEM INTEGRATION 4-2
4-5	MAXIMIZE DAYLIGHT POTENTIAL 4-3
4-6	GLAZING ORIENTATION 4-4
4-7	GLAZING CHARACTERISTICS 4-5
4-8	QUANTITY OF GLAZING 4-6

4-9	GLARE AND CONTRAST CONTROL.....	4-10
4-10	ACTIVE DAYLIGHTING	4-11
4-11	PHYSICAL MODELING.....	4-11
4-12	COMPUTER SIMULATION	4-11

CHAPTER 5 LIGHTING EQUIPMENT

Paragraph	5-1	BUDGET CONSIDERATIONS	5-1
	5-2	LUMINAIRES	5-2
	5-3	LAMPS	5-7
	5-4	BALLASTS AND POWER SUPPLIES.....	5-14
	5-5	LIGHTING CONTROLS.....	5-16
	5-6	EMERGENCY AND EXIT LIGHTING	5-20
	5-7	INSTALLATION REQUIREMENTS	5-21

CHAPTER 6 INTERIOR APPLICATIONS

Paragraph	6-1	INTRODUCTION.....	6-1
	6-2	LIGHTING CALCULATIONS FOR INTERIOR SPACES	6-1
		INTERIOR DESIGN APPLICATIONS:	
		OFFICES.....	6-3
		Lobbies.....	6-3
		Corridors.....	6-5
		Individual Offices	6-7
		Open Offices	6-10
		Waiting Areas	6-13
		Conference Rooms	6-15
		Board Rooms	6-17
		Ceremonial Areas.....	6-19
		Lounge Areas	6-21
		Office Support Areas	6-23
		Storage Rooms	6-25
		Mechanical Rooms	6-26
		Restrooms	6-27
		EDUCATIONAL FACILITIES.....	6-29
		Classrooms	6-29
		Auditoriums	6-31
		HEALTH CARE FACILITIES	6-34
		Waiting Rooms	6-34
		Pharmacy	6-36
		FOOD SERVICE	6-38
		Kitchens.....	6-38
		Cafeterias	6-40
		Enlisted Dining Rooms	6-42
		Officer Dining Rooms	6-44
		RECREATIONAL FACILITIES	6-46
		Indoor Swimming Pools.....	6-46
		Indoor Tennis Courts.....	6-47

Indoor Basketball Courts	6-48
Locker Rooms	6-50
MAINTENANCE FACILITIES	6-51
Vehicle Storage / Repair Areas	6-51
Aircraft Hangars and Shelters	6-53
Motorpools.....	6-55
Warehouses	6-57
RESIDENTIAL HOUSING	6-59
Bedrooms	6-59
Hallways	6-61
Laundry Rooms	6-62
Kitchens.....	6-63
Dining Rooms	6-65
Living Rooms.....	6-67
Recreation Rooms.....	6-69
Bathrooms	6-71
Garages.....	6-73
Bachelors Quarters (Barracks)	6-75
CHILDCARE FACILITIES.....	6-77
Daycare Indoor Play Areas.....	6-77
Daycare Indoor Rest Areas	6-79
PARKING STRUCTURES.....	6-81

CHAPTER 7 EXTERIOR APPLICATIONS

Paragraph	7-1	INTRODUCTION.....	7-1
	7-2	CALCULATIONS.....	7-1
		EXTERIOR DESIGN APPLICATIONS:	
		PARKING FACILITIES	7-3
		Parking Lots	7-3
		BUILDING LIGHTING.....	7-7
		Entrances	7-7
		Housing Areas.....	7-9
		PEDESTRIAN AREAS	7-11
		Walkways	7-11
		Plazas.....	7-13
		VEHICLE TRAFFIC AREAS.....	7-15
		Roadways and Streets	7-15
		Driveways.....	7-18
		MARINAS	7-20
		EXTERIOR RECREATIONAL AREAS	7-22
		Baseball and Softball Fields	7-22
		Tennis Courts	7-24
		Basketball Courts	7-26
		Football Fields	7-28
		Playgrounds	7-29
APPENDIX A		REFERENCES	A-1

APPENDIX B	PHYSIOLOGICAL ISSUES.....	B-1
APPENDIX C	GLOSSARY	C-1
APPENDIX D	ECONOMIC ANALYSIS OF PARKING LIGHTING.....	D-1

FIGURES

<u>Figure</u>	<u>Title</u>	
2-1	Examples of direct glare.....	2-3
2-2	Minimize direct glare with cut-off fixtures	2-3
2-3	Minimize direct glare with indirect lighting	2-3
2-4	Semi-indirect lighting minimizes indirect glare.....	2-4
2-5	Uniform ceiling brightness	2-5
2-6	Uniform illuminance.....	2-5
2-7	Lumen Effectiveness Multipliers vs Luminance.....	2-8
2-8	Downlighting versus lighting surfaces	2-9
2-9	Example of downlighting versus lighting surfaces	2-9
3-1	Los Angeles, 1908; Lost Angeles 1976.....	3-6
3-2	Unshielded and non-cutoff luminaires lead to light pollution.....	3-6
3-3	Examples of IESNA full cut-off luminaires	3-7
3-4	Glare results in loss of visibility	3-7
3-5	Full cut-off luminaires versus unshielded floodlights	3-8
3-6	A change in furniture configuration affects uniformity.....	3-10
4-1	Examples of daylighting strategies.....	4-4
4-2	Building Orientation can maximize daylight exposure	4-4
4-3	Example of architectural shading devices	4-5
4-4	Diagrams of toplighting strategies	4-7
4-5	Example of toplighting application.....	4-8
4-6	Example of clerestory application.....	4-8
4-7	Examples of sidelighting applications.....	4-9
4-8	Examples of roof shapes.....	4-10
4-9	Examples of splayed skylights	4-10
4-10	Example of an active daylighting system.....	4-11
5-1	Pendant mounted luminaires.....	5-3
5-2	Wall mounted luminaires.....	5-3
5-3	Ceiling/surface mounted luminaires	5-3
5-4	Recessed and semi-recessed luminaires.....	5-4
5-5	Track mounted luminaires.....	5-4
5-6	Pole mounted luminaires.....	5-5
5-7	Efficacy comparison of light sources	5-9
5-8	Typical Exit sign	5-20

TABLES

<u>Table</u>	<u>Title</u>	
2-1	Lumen effectiveness multipliers vs. high pressure sodium.....	2-7
4-1	Comparison of Glass Types	4-6
5-1	Exterior Luminaire Distribution Classification	5-6
5-2	Exterior Luminaire Cutoff Classification.....	5-6
5-3	NEMA Field Angle Classification	5-7
5-4	Comparison of Lamps	5-8
5-5	Recommended Control Devices for Different Building Applications	5-18
5-6	Lighting Control Energy Savings Examples	5-19
5-7	Lighting Control Considerations	5-19
7-1	Recommended Illuminance Uniformity Ratios.....	7-2

CHAPTER 1

INTRODUCTION

1-1 **PURPOSE AND SCOPE.** This UFC provides guidance for the design of interior and exterior lighting systems for the Unified Facilities Criteria based on the Illuminating Engineering Society of North America's (IESNA) *Lighting Handbook Reference and Application*, 9th Edition (hereafter called *Lighting Handbook*) and current recommended practices. This UFC meets the current IESNA standard of practice and addresses general lighting requirements for Department of Defense (DoD) facilities. Specific requirements not outlined here may apply to facilities overseas.

1-1.1 **Lighting Handbook.** In 2000, the IESNA published the 9th Edition of the handbook, which changed the direction of lighting design criteria. In previous editions, illuminance values were given as the strongest basis for design. In the 9th edition of the *Lighting Handbook*, the single focus on the illuminance criteria is no longer possible. Now the emphasis is on quality based design. Chapter 10 of the handbook, "Quality of the Visual Environment" formalizes these issues in a Lighting Design matrix and rates the importance of each for different applications.

1-1.2 **Lighting Design Criteria.** Lighting practitioners must evaluate the application and consider the important lighting design criteria, including direct glare, surface luminances, and uniformity. Also, the importance of daylight on human health and productivity is emphasized.

1-1.3 **Exterior Lighting.** Exterior lighting design now addresses the role of glare in creating poor visibility. Over-lighting and discontinuity between areas is also addressed as this could cause adaptation delays when moving from one area to another. Also, the increased effectiveness of white light on enhanced peripheral detection for exterior and other low lighting level applications is addressed.

1-2 **APPLICABILITY.** These guidelines apply to all service elements and contractors designing interior or exterior lighting systems for new and retrofit construction projects.

1-3 **REFERENCES.** Appendix A contains a list of references used in this document.

CHAPTER 2

LIGHTING DESIGN CONSIDERATIONS

2-1 **INTRODUCTION.** The *Lighting Handbook* defines visibility as, “the ability to extract information from the field of view.”¹ Visibility is affected by glare, uniformity, illuminance, surface brightness, and lighting components. The consideration of these factors improves task performance, mood and atmosphere, visual comfort, aesthetic judgment, health, safety and well-being, and social communication. Additionally, sustainability concerns, lighting control, and maintenance issues all affect the amount of energy required to achieve, operate, and maintain this level of visibility. The *Lighting Handbook*, Chapter 10 “Quality of the Visual Environment” discusses each of these aspects in detail. A lighting design guide matrix lists the critical design issues that must be followed.

2-1.1 The criteria outlined in this UFC describe the most relevant issues for DoD facility applications and it refers extensively to the *Lighting Handbook*. However, the *Lighting Handbook* criteria may at times be superseded by other UFC requirements.

2-1.2 This chapter describes the most important lighting design considerations. Each issue is discussed with the specific requirements that must be met as well as the items that should be considered during the design process. To use this document, review these requirements and considerations and refer to chapters 3 – 5 to get more detailed information on sustainability issues, daylighting, and lighting equipment. Chapters 6 and 7 give specific examples of various lighting applications. If a designer has very little time, these examples provide immediate and specific equipment recommendations that can be used to meet the outlined criteria.

2-2 VISIBILITY.

2-2.1 Task visibility describes how size, brightness, and contrast of a particular activity affect the lighting required to view that activity. The ability to actually perform a task well includes other non-visual human factors such as skills and experience, independent of the task visibility.

2-2.1.1 Large tasks generally require less illuminance, brightness, and contrast to be performed. Small detailed tasks may require task lighting to increase the light level significantly. Knowing a description of the task is essential to designing the lighting for that task. The luminance or brightness of a task increases the task visibility. Brighter tasks are easier to see, so long as it is not so much brighter than its surroundings that it becomes uncomfortable or a source of direct glare. As task contrast decreases, the light level required to see it will increase. If the contrast is too low, it will be difficult to distinguish various components of the task, reducing visibility.

¹ “Quality of the Visual Environment”, *Lighting Handbook Reference and Application*, Chapter 10, Ninth Edition (New York: The Illuminating Engineering Society of North America, 2000), p. 10-1.

2-2.1.2 Way finding refers to the visual guidance provided by the lighting system and the visual elements illuminated. This visual guidance may be illuminated signage that directs occupants to various destinations, or it may be more subtle aids such as continuity and hierarchy of lighting equipment that reinforces areas of similar use. By using the same luminaires for areas of the same use, a consistent pattern is established that visually guides and orients building occupants. Accent lighting can also be used to draw attention to specific areas by increasing the brightness.

2-2.1.3 In exterior applications, the size and type of lighting equipment provides visual cues about the surroundings. Bollards and low pedestrian scale poles often signify pedestrian walkways or plazas. Roadway poles may alert pedestrians to intersections in the same way that pedestrian poles or bollards may alert motorists to crosswalks.

2-3 **GLARE.**

2-3.1 Direct glare is caused by excessive light entering the eye from a bright light source. The potential for direct glare exists anytime one can “see” a light source. With direct glare, the eye has a harder time seeing contrast and details. A system designed solely on lighting levels, tends to aim more light directly towards a task, thus producing more potential for glare. The effective use of indirect light minimizes the negative effects of direct glare. In some circumstances such as entries and checkpoints, glare can be used to increase vertical illuminance on approaching vehicles or individuals while increasing visibility for guards and patrols.

2-3.1.1 Causes of direct glare include an exposed bright light source, for example an HID high bay luminaire, or an exterior floodlight. Overhead T5HO fluorescent lamps in a downlight also can cause direct glare.

2-3.1.2 Direct glare can be minimized with careful equipment selection and placement. In interior applications, indirectly light the walls and ceiling. A limited amount of direct light can provide accent and task lighting. In exterior applications, use fully shielded luminaires that directs light downwards towards the ground or a building façade.

Figure 2-1. Examples of direct glare.



Figure 2-2. Minimize direct glare with IESNA full cut-off luminaire.

Figure 2-3. Minimize direct glare with indirect lighting



2-3.2 Indirect or reflected glare is caused by light reflecting off the task or pavement in such a manner that the contrast is “washed out”. Many work situations position the

light directly in front of the task, producing reflected glare. Unshielded streetlights can also produce reflected glare on wet pavement, washing out lines on the road. Reflected glare will limit one's ability to "see" contrast.

2-3.2.1 Like direct glare, indirect glare can be minimized with the type and layout of lighting equipment. For interior applications, locate direct light to the side or behind a critical task. Use semi-indirect light to bounce light off of surfaces in order to provide uniform low glare light with less reflected glare. For exterior lighting, direct the light away from the observer with the use of low glare, fully shielded luminaires.

Figure 2-4. Semi-indirect lighting minimizes indirect glare.



2-3.3 Overhead glare. Direct luminaires that are immediately over an individual can cause glare even though the light source is not in the field of view. This type of glare can produce the same negative effects as direct or reflected glare including eye-strain and headaches.

2-3.3.1 To minimize overhead glare, use indirect luminaires to light the ceiling surface and avoid totally direct luminaires. Where direct luminaires are used, make sure that individuals are not working directly under them.

2-3.4 Requirements to minimize glare:

- Follow IESNA recommendations for individual lighting application. Refer to Chapter 6 and 7 of this UFC or to the *Lighting Handbook*, Chapter 10 "Quality of the Visual Environment" for specific criteria.
- For roadway applications, use fully shielded luminaires. Refer to "exterior luminaires" in Chapter 5 "Lighting Equipment" and Chapter 7 "Exterior Applications."

2-3.5 Considerations to minimize glare:

- Indirectly light the ceiling and walls for interior ambient lighting systems. Refer to specific applications in Chapter 6, "Interior Applications".

- Use direct light only in limited amounts for task and accent light. Refer to specific applications in Chapter 6, “Interior Applications”.
- For exterior applications, use fully shielded luminaires (see exterior luminaires in Chapter 5, “Lighting Equipment” and Chapter 7, “Exterior Applications”).

2-4 **UNIFORMITY.** Lighting level or illuminance uniformity is important on work surfaces where sustained tasks are performed as well as on wall and ceiling surfaces that make up a significant portion of the field of view. Poor uniformity can cause adaptation problems. It is very important to prevent “spotty” lighting especially in interior areas where people are working, and exterior areas where safety and security are concerns.

2-4.1 Flicker or strobing of luminaires can cause annoyance as well as headaches and fatigue. This may be caused by fluorescent ballasts near the end of life or placement of luminaires in relation to ceiling fans. If ceiling fans are required in a space, position the luminaires so that they are suspended below the level of the fans.

Figure 2-5. Uniform ceiling brightness.



Figure 2-6. Uniform illuminance.



2-4.2 Requirements for appropriate uniformity:

- Follow IESNA uniformity criteria for specific areas unless superseded by other UFC criteria. Refer to specific application requirements in Chapters 6 and 7, “Interior and Exterior Applications” and Chapter 10 of the *Lighting Handbook*.

2-4.3 Considerations for appropriate uniformity:

- In office areas, uniformity should not exceed 5:1 in immediate work surrounds, not including accent lighting. Also, refer to Chapter 6, “Interior Applications”.
- Exterior uniformity should not exceed 10:1 along areas of use including roadways, walkways, and parking areas. Refer to specific application in

Chapter 7, "Exterior Applications".

2-5 **ILLUMINANCE.** Illuminance refers to the light level, or amount of light falling on a surface. It is measured in lux or footcandles. Horizontal illuminance refers to the amount of light falling on a horizontal surface. This type of illuminance is often measured on a desk, work surface, or floor. Vertical illuminance refers to the amount of light falling on a vertical surface such as white boards, signs, and walls. Vertical illuminance on peoples' faces is also important for identification at entries and security checkpoints.

2-5.1 Traditionally, illuminance has been the basis of lighting design. However, we "see" brightness; we don't see lighting levels or lux. Since the revision of the IESNA guidelines, new standards regarding design must be followed. The *Lighting Handbook* chapter on "Quality of the Visual Environment" (QVE) has added many other design factors besides illuminance. It is important to review all of the design criteria issues in order to prioritize issues. In many cases illuminance is no longer a top priority. Lighting wall and ceiling surfaces is usually more important than providing high levels of horizontal illuminance. In order to provide flexibility and interest in a space, light ceiling and wall surfaces with lower ambient lighting levels. Provide higher illuminance levels with individualized task lighting.

2-5.2 There are three different types of visual responses: Photopic or our day vision (3 cd/m² and higher), Scotopic or our night vision (.001 cd/m² and below) and mesopic or a combination of night and day vision (.001 cd/m² to 3 cd/m²). (*Lighting Handbook* page 1-6). The majority of exterior lighting is designed in the mesopic range.

2-5.2.1 Photopic sensitivity peaks at 555 nm in the green-yellow range. Scotopic vision sensitivity peaks at 507 nm more in the blue light range. Mesopic vision varies between these values depending on the lighting level. As the lighting levels become lower, lamp sources with more blue light become more effective in nighttime vision.

2-5.2.2 Since lamp lumen ratings are all based on photopic sensitivity, they need to be adjusted for nighttime applications. "Photopic and scotopic lumens must be determined from the spectral power distribution of the light source" (*Lighting Handbook* page 1-6.) In addition, photopic luminous efficiency function applies to visual fields of size 2 degrees or less. (*Lighting Handbook* page 2-1). This means that only tasks that are on-axis or one that is focusing straight ahead apply to the photopic lamp lumen ratings. Any task that is in our peripheral vision does not. Peripheral vision shifts to shorter wavelength sensitivity. (*Lighting Handbook* page 3-9).

2-5.2.3 There are numerous research projects evaluating the most effective method of determining mesopic lumen ratings for lamp sources. All of these methods show a significant effectiveness of a white light source such as metal halide over a high-pressure sodium light source. An example used by Dr. Mark Rae (editor of the *Lighting Handbook*) shows that for a typical roadway luminance of 0.3 cd/m², a 400 watt HPS produces 135 lux (13.5 footcandles) and consumes 400 watts plus ballast watts. A metal halide system with equal visibility produces 86 lux (8.6 footcandles) consuming 335 watts plus ballast watts. In another study involving military facilities, both

brightness and color perception were improved under white metal halide light under mesopic conditions.² By using white light, peripheral vision is improved and energy is saved compared to a HPS or LPS lighting system.

2-5.2.4 For all exterior lighting applications where peripheral vision is important such as detecting pedestrians and other potential off axis activity, white light as produced by a metal halide, fluorescent, or induction lamp is recommended.

2-5.2.5 Lumen effectiveness multipliers may be used to account for the improved visibility provided by white light as opposed to HPS. Table 2-1 lists lumen effectiveness multipliers for three different sources. To use the table, determine the appropriate luminance condition and the source being used. Note that most computer lighting programs can calculate luminance as an option. From the table, find the corresponding multiplier. This value is then multiplied by the lumen output of the lamp published by the manufacturer to determine the *effective* lumens. Notice that during photopic (10 cd/m²) conditions, the multiplier for all sources is 1.00 and no adjustment needs to be made to the lamp lumen output. At lower brightness levels, white metal halide light becomes more effective and low-pressure sodium becomes less effective. (Because sources are being compared, one must be set as baseline. In this case, high-pressure sodium is the base and all values are 1.0 under any brightness condition.)

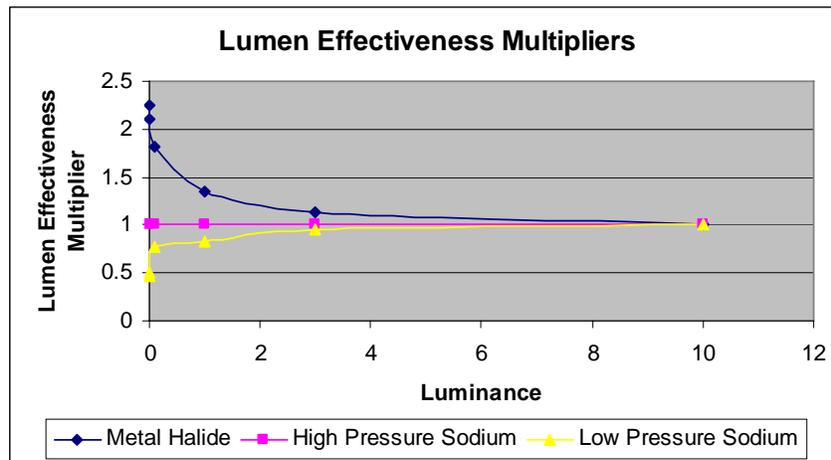
Table 2-1. Lumen Effectiveness Multipliers vs. High Pressure Sodium³

Luminance (cd/m ²)	0.001	0.01	0.1	1	3	10
Metal Halide	2.25	2.11	1.82	1.35	1.13	1.00
High Pressure Sodium	1.00	1.00	1.00	1.00	1.00	1.00
Low Pressure Sodium	0.47	0.51	0.78	0.82	0.95	1.00

² "Evaluation of Visual Function Under Different Light Sources", (Lighting Research Center, Rensselaer Polytechnic Institute, Troy, NY, December 11, 1995) p15.

³ Lewin, Ian. "Lumen Effectiveness Multipliers for Outdoor Lighting Design." Journal of the Illuminating Engineering Society, Summer 2001.

Figure 2-7. Lumen Effectiveness Multipliers vs. Luminance⁴



2-5.3 Requirements for adequate illuminance:

- Follow IESNA recommendations by evaluating all QVE criteria including illuminance, paying particular attention not to overlight. Refer to specific applications in Chapters 6 and 7.

2-5.4 Considerations for adequate illuminance:

- Design ambient lighting levels to 1/3 to 1/2 task lighting levels. Add task lighting to increase light level.
- Use white light sources for exterior lighting. Refer to lamp recommendations in Chapter 5, "Lighting Equipment".

2-6 **SURFACE BRIGHTNESS.** We "see" brightness; we don't see lighting levels or lux. Our perception of spaces depends on how surfaces are lighted. For example, if walls are lighted, the space feels large and open. With the walls and ceiling lighted, a space looks bright and cheery. With dark room surfaces, the space feels oppressive and "cave-like"⁵. It is important to light vertical surfaces such as walls and building facades as a first priority, then horizontal surfaces such as ceilings and canopies. The least effective surfaces to light are floors.

2-6.1 Traditional lighting design has emphasized lighting level as the only criteria, ignoring the importance of surface brightness. For a more effective design, light the walls and ceiling and use light colored surfaces.

⁴ Lewin, Ian. "Lumen Effectiveness Multipliers for Outdoor Lighting Design." Journal of the Illuminating Engineering Society, Summer 2001.

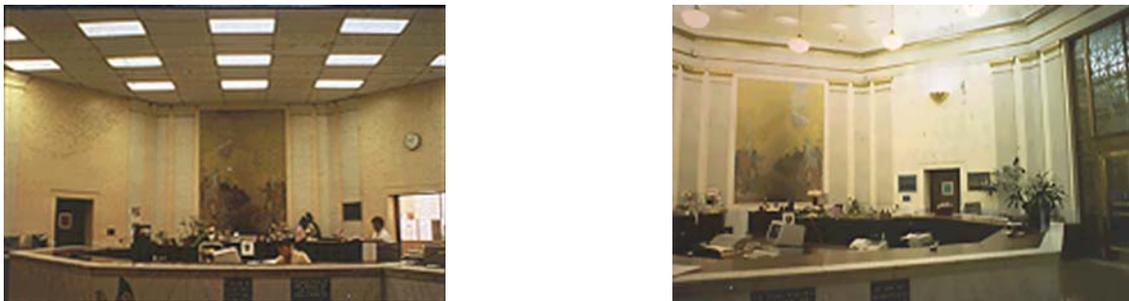
⁵ "Vision and Perception", *Lighting Handbook Reference and Application*, Chapter 3, Ninth Edition (New York: The Illuminating Engineering Society of North America, 2000), p. 3-38.

2-6.2 When using fluorescent lamps to light surfaces, the color-rendering index of the lamps determines how colors will appear. In spaces where color appearance is important, a higher color-rendering index (CRI) will improve the appearance of colors.

Figure 2-8. Downlighting only results in spaces feeling dark and “cave-like”. Lighting surfaces improves the “feel” of the space.



Figure 2-9. Example of the same space with downlighting only (left) and then with improved surface brightness (right).



2-6.3 Considerations for appropriate surface brightness:

- Provide high surface reflectances for walls (60% minimum) and ceilings (85% minimum).
- Light ceilings with semi-indirect wall or pendant mounted lighting. Refer to specific application in Chapter 6, “Interior Applications”.
- Light walls with wallwashers Refer to Chapter 5, “Lighting Equipment”.
- Direct daylight to ceiling and walls. Refer to Chapter 4, “Daylighting”.
- For exterior applications, light vertical surfaces that are in pedestrians’ field of view. Refer to specific application in Chapter 7, “Exterior

Applications”.

2-7 **AMBIENT/TASK/ACCENT SYSTEMS.** A lighting system made up of layers of ambient light, task light, and accent light improves the visual comfort in a space as well as reduces the amount of lighting energy used. Lighting with these three layers balances the contrast ratios between objects in an occupant’s field of view, adds some visual interest, and provides flexibility in controlling what is lighted. This approach also lowers the amount of energy consumed for lighting. By providing task lighting only where required, the ambient light level can be much lower. For example, an entire open office does not need to have a light level suitable for reading detailed tasks, only the desktops. In such a case the ambient level may be low, with task lighting increasing the light to necessary levels at the necessary locations.

2-7.1 Additionally, when the system is designed with these “sub-systems”, greater control flexibility results in greater opportunity for reducing energy use. Task lighting can be turned off at a workstation not in use. This control flexibility also results in greater user satisfaction. The LightRight Consortium (www.lightright.org) is working on extensive research to determine how personally controlled and “ergonomic” lighting affects productivity and occupant comfort.

2-7.2 Ambient lighting provides general illuminance and surface brightness for wayfinding and transitional tasks. Lighting high reflectance surfaces will create the perception of brightness and provide enough ambient light for a space.

2-7.3 Task lighting increases the illuminance of a particular task at close range. The type of lighting and the light level vary with the task. General reading will require a lower light level than detailed accounting tasks. Computer use may require light on an adjacent written task, but not on the computer screen itself.

2-7.4 Accent lighting highlights particular architectural features or artwork. If the ambient light level is too high, no amount of accent lighting will increase the brightness of a feature enough to make the contrast apparent. Selective use of accent lighting also increases its effect. Too much accent lighting will wash out the impact of any single feature.

2-7.5 Considerations to incorporate ambient/task/accent systems:

- Design a lighting system to provide a minimal amount of ambient light. Add task lighting to increase light level at the point of use. Add accent lighting for visual interest. Refer to specific application in Chapter 6, “Interior Applications”.

2-8 **LIGHTING CONTROL.** Controlling the electric lighting to respond to daylight availability and occupancy are some of the most effective methods of reducing lighting energy and cooling loads. The heat from lighting typically accounts for 15% to 20% of a

building's cooling load.⁶ Devices also can provide for individual control over the indoor environment resulting in higher occupant satisfaction. Table 5-5 and Table 5-7 in Chapter 5, "Lighting Equipment" describes space types, control strategies which may be most appropriate, and potential energy savings. ASHRAE/IESNA 90.1-1999 lighting control requirements must be met at a minimum. A summary of these control requirements is listed below. Refer to ASHRAE/IESNA 90.1 -1999 for specific control implementation and exceptions.

2-8.1 Lighting control requirements for ASHRAE/IESNA 90.1-1999:

- Automatic Lighting Shutoff (9.2.1.1.) Interior lighting in buildings larger than 5000 ft² must be controlled with an automatic control device to shut off building lighting in all spaces.
- Space Control (9.2.1.2.) Each space enclosed by ceiling-height partitions must have at least one control device to independently control the general lighting within the space. Each control device must be activated either manually by an occupant or automatically by sensing an occupant.
- Exterior Lighting Control (9.2.1.3.) Lighting for all exterior applications not exempted in 9.1 and 9.3.2 must be controlled by a photosensor or astronomical time switch that is capable of automatically turning off the exterior lighting when sufficient daylight is available or the lighting is not required.
- If daylighting is used, electric lighting must be integrated with daylight controls to realize energy savings potential. Refer to Chapter 3, "Sustainability", Chapter 4, "Daylighting" and Chapter 5, "Lighting Equipment – Controls".
- Ballast selection must match control strategies. Instant start ballasts must not be used in areas where lighting is controlled with occupancy sensors. Refer to Chapter 5, "Lighting Equipment – Ballasts and Power Supplies", for ballast selection and control compatibility.

2-8.1 Lighting zones allow for optimal control of the overall lighting system. A lighting zone refers to a group of luminaires that are controlled together. Many portions of the lighting system can be controlled separately including ambient, task, accent, and display lighting. When controlling electric light in response to daylight, zones can be arranged according to the luminaires proximity to windows or skylight. For example, rows of luminaires closest to a window wall should be controlled separately from the interior rows. Occupancy sensors may control a zone of luminaires over a group of workstations in an office.

⁶ "Energy Management", *Lighting Handbook Reference and Application*, Chapter 26, Ninth Edition (New York: The Illuminating Engineering Society of North America, 2000), p. 26-1.

2-8.2 Daylight-based controls detect the amount of daylight in a space and either dim luminaires accordingly or switch off unnecessary luminaires. Sensors must be located according to manufacturer's recommendations and be adjusted so that short changes in daylight (caused by passing clouds) do not trigger the sensor.

2-8.3 Occupancy-based controls detect individuals with passive infrared, ultrasonic, or dual technology. They may be ceiling mounted to cover large spaces or they may be integrated with wall switches for smaller spaces. Occupancy sensors are ideal for areas of convenience such as storage rooms where individuals often have their hands full when entering or leaving. Refer to Chapter 5 "Lighting Equipment" for more detail on types of occupancy-based controls.

2-8.4 Timed switching can be incorporated into wall switches for small spaces. These are ideal for janitor closets or other areas where the lighting might otherwise be left on.

2-8.5 Timeclocks control larger areas or groups of luminaires. They are often incorporated with photocells to control exterior luminaires. In such cases, the daylight sensor may turn luminaires on at dusk and then all luminaires are turned off by the timeclock at a preset time.

2-8.6 Personal Control typically refers to a Digital Addressable Lighting Interface (DALI) system. Control devices that utilize this protocol allow individual luminaires to be "addressed" to an individual workstation. This provides an occupant with the ability to control and dim his or her own luminaire even in an open office configuration.

2-8.7 Building-wide control systems may monitor as well as control the lighting systems throughout the building. Often, devices are combined to control both HVAC and lighting systems.

2-9 SUSTAINABILITY ISSUES.

2-9.1 Sustainability refers to a broad range of design strategies aimed at reducing the resource use and environmental impact of the built environment. Areas of concern include energy efficiency, resource conservation, reuse, and recycling, indoor air quality. The concept of holistic design brings all of these issues into consideration. This design approach integrates various building disciplines and systems. Integrated design requires an understanding of how one building system affects other systems and how to optimize their interdependence. For example, utilizing energy efficient light sources and turning off fixtures that are not required, minimizes electricity requirements for the building lighting system. However, these same strategies also reduce the amount of heat produced by all light sources. With this reduction in heat, a smaller mechanical system may be required to cool the building. Less space required for mechanical equipment may mean more space for program requirements.

2-9.2 Requirements for sustainable design:

- Use the most energy efficient light source suitable for the application.

Some inefficient light sources are prohibited. Refer to Lamps in Chapter 5, "Lighting Equipment" for prohibited light sources.

- Minimize light pollution and light trespass by not overlighting and using shielded exterior luminaires. Refer to Chapter 3, "Sustainability Issues – Light Pollution, Light Trespass".
- Evaluate sustainable measures using life cycle cost analysis rather than initial cost comparisons. Refer to Chapter 3, "Sustainability Issues – Economic Issues".
- Light sources containing mercury should be recycled. Refer to Chapter 3, "Sustainability Issues – Material Issues". This cost must be included in a life cycle cost analysis.

2-9.3 Considerations for sustainable design:

- Consider daylighting techniques. Refer to Chapter 3, "Sustainability Issues" and Chapter 4, "Daylighting". If daylight strategies are used, additional coordination is required with the architect and mechanical engineer. Additionally, electric lighting controls must be incorporated to take advantage of the potential energy savings.

2-10 **SECURITY.**

2-10.1 In most exterior applications, security is best achieved by reducing glare. In some circumstances such as entries and checkpoints, glare can be used to increase vertical illuminance on approaching vehicles or individuals while increasing visibility for guards and patrols. Refer to MIL-HDBK-1013/1A and UFC 4-011-02.

2-11 **MAINTENANCE ISSUES.**

2-11.1 Inventory Minimization. Consolidate lamp types across luminaire types to minimize the number of various lamps that need to be stocked by maintenance. When designing lighting systems for a facility, carefully consider trade-offs between specifying the most appropriate wattage lamp and introducing too many lamp types on a project. This may include maximizing the use of 4 ft (1.2 m) linear fluorescent lamps.

2-11.2 Group Re-lamping involves replacing all of the lamps in a particular area after a specified time of operation rather than spot re-lamping as individual lamps burn out. The benefits of this approach include a more consistent light level and reduced maintenance costs, especially in areas that require lifts or scaffolding for lamp replacement.

2-11.3 Accessibility. When designing lighting systems, especially in high ceiling areas such as atriums, make provisions for maintenance access and lamp replacement. Wall mounted indirect luminaires are easier to access than downlights. Lowering devices may lower pendants to the floor for maintenance. Provide safety hooks for

securing to while working on a high luminaire. If a lift will be used, a path of travel must be determined that accommodates the lift equipment.

2-11.4 Equipment Life. Select lamps, ballasts, and controls that are rated or guaranteed for long useful lives. An incandescent lamp may have a very low initial cost but may have to be replaced several times a year, while an induction lamp or LED may not be replaced for decades.

2-11.5 Considerations for improved maintenance:

- Minimize lamp types on an individual project.
- Group re-lamp luminaires within individual areas.
- Provide all luminaires with means of re-lamping and maintenance.
- Select equipment and sources with long operating lifetimes. Refer to Chapter 5, "Lighting Equipment – Lamps", for average lamp life of various sources.

CHAPTER 3

SUSTAINABILITY ISSUES

3-1 **INTRODUCTION.** The sustainable characteristics of a building are difficult to measure and quantify. Two building rating systems attempt to do this. The United States Green Building Council, Leadership in Energy and Environmental Design (LEED™) rating system and the Sustainable Project Rating Tool (SPiRiT) may be used to rate projects. Designers must verify the goals and requirements for an individual project. Incorporating these rating systems into the design process requires a careful analysis of both the cost and the benefits of the strategies outlined in the rating systems. Any design strategy has both synergies and tradeoffs with other building systems and the project budget. Lighting design addresses several sustainable issues and presents multiple strategies that can be considered in a particular project: daylight utilization, lighting controls, energy efficiency, materials, light pollution, and light trespass. All of these issues have significant impacts on the project budget that can best be evaluated with a life-cycle cost analysis. Additionally, the most sustainable solution to a new building project may be to renovate an existing building. In this situation, certain lighting issues must be addressed to improve the efficiency and visibility of an existing system.

3-2 **BUILDING RATING SYSTEMS.** Because interpretations of sustainability vary dramatically, building rating systems serve as a defined baseline for and a means of comparison between building projects. Sustainable design inherently requires integrated design. Rating systems provide design and construction teams with a framework of sustainable and efficient strategies and the synergies and trade-offs that exist between them. Refer to the Whole Building Design Guide, Design Objectives at <http://www.wbdg.org/design/index.php?cn=3&cx=0> and Daylighting at <http://www.wbdg.org/design/resource.php?cn=0&cx=0&rp=11> for more information. Sustainable goals for new facility projects vary with the military branch.

3-2.1 Currently, **Army** FY06 and MILCON projects must meet a SPiRiT rating of Gold. Refer to CECW-EE (1110), *Sustainable Design and Development* for further details.

3-2.2 **Navy** facilities must achieve a LEED Certified level. Refer to NAVFAC INSTRUCTION 9830.1, *Sustainable Development Policy*.

3-2.3 The US Green Building Council, Leadership in Energy and Environmental Design (LEED™) Rating System. The LEED™ Version 2.1 rating system measures the “green” performance of new and existing commercial, institutional, and high-rise residential buildings. The system is divided into six categories: Sustainable Sites, Water Efficiency, Energy and Atmosphere, Materials and Resources, Indoor Environmental Quality, and Innovation and Design Process.¹ Within each category, multiple credits can be obtained in addition to certain prerequisites that must be met to

¹ US Green Building Council. “Introduction”. LEED™ Reference Guide. Copyright 2001. p 3.

qualify the project. All of the credits outline quantifiable and verifiable criteria. The lighting design for a project currently affects several credits and prerequisites: Sustainable Sites Credit 8, Light Pollution Reduction; Energy and Atmosphere Prerequisite 2, Minimum Energy Performance, Credit 1, Optimize Energy Performance; and Indoor Environmental Quality Credit 6, Controllability of Systems and Credit 8, Daylight and Views. Refer to the latest version of the LEED™ rating system for exact requirements.

3-2.3.1 Sustainable Sites Credit 8, Light Pollution Reduction. This credit addresses exterior site lighting and its contribution to light pollution and potential for light trespass. These issues are addressed in Chapter 3 “Sustainability Issues” along with strategies to minimize both.

3-2.3.2 Energy and Atmosphere Prerequisite 2, Minimum Energy Performance. This prerequisite requires that the provisions of ASHRAE/IESNA 90.1 be met as a minimum baseline of building energy efficiency.

3-2.3.3 Energy and Atmosphere Credit 1, Optimize Energy Performance. This credit addresses the overall building energy consumption. Because lighting can be a significant electrical load and also a cooling load on the HVAC system, reducing the lighting energy use minimizes the total building energy requirements. Strategies outlined in this UFC such as daylight integration, surface brightness, controls, and light source selection all serve to reduce the energy used by the lighting system.

3-2.3.4 Indoor Environmental Quality Credit 6, Controllability of Systems. Building occupants prefer to have control over their interior environment including the lighting system. This credit requires a certain degree of control per unit area of the lighting.

3-2.3.5 Indoor Environmental Quality Credit 8, Daylight and Views. The controlled introduction of daylight into interior spaces reduces the lighting energy requirement and improves the comfort of the occupants. This credit outlines requirements for access to daylight and to view glazing within a space.

3-2.4 Sustainable Project Rating Tool (SPiRiT). The SPiRiT system is based on the LEED™ 2.0 rating system.² However, the number of points given for each credit is revised and additional credits are added so that the possible points total 100. The categories are the same except Innovation and Design Process is replaced with three additional categories: Facility Delivery Process, Current Mission, and Future Missions.

3-2.4.1 Facility Delivery Process, Holistic Deliver of Facility. This credit requires that building systems (including lighting) be evaluated on a life cycle cost basis rather than first cost alone.

² “The Sustainable Project Rating Tool”, *US Army Corps of Engineers, Engineer Research and Development Center*, June 2002 <<http://www.cecer.army.mil/sustdesign/SPiRiT.cfm>>

3-2.4.2 Current Mission, Operation and Maintenance. The lighting system must be included in the operation and maintenance program. Also, select lighting equipment that is appropriately durable and also makes sense with the life cycle cost analysis.

3-2.4.3 Current Mission, Soldier and Workforce Productivity and Retention. Many of the visibility issues outlined in Chapter 2 “Lighting Design Considerations”, including daylight, glare, and surface brightness all affect occupant comfort and productivity.

3-2.4.4 Future Missions, Functional Life of Facility and Supporting Systems. Evaluate the expected life of lighting equipment and the cost of replacement in the building life cycle costs analysis.

3-2.4.5 Future Missions, Adaptation, Renewal and Future Uses. Consider lighting system designs that are not dependent on current furniture layout and are flexible for changes in use. Task / ambient lighting systems, as described in Chapter 2, “Lighting Design Considerations”, achieve this goal.

3-3 **COSTS / BENEFITS.** While the cost and benefit of any design strategy must be evaluated with respect to an individual project, some issues are common to the sustainable design of any facility.

3-3.1 Daylighting. Utilizing daylight to provide the light in the building has the benefit of reducing lighting energy requirements while improving the quality of the indoor spaces. However, it also requires a significant increase in design time and coordination between structural, mechanical, and electrical systems. This strategy may require additional modeling to ensure that daylight is provided without glare or increased heat gain. This results in increased design requirements. Additionally, in DoD facilities, Antiterrorism (AT) criteria (see UFC 4-010-01) increase the required strength of glazing. Therefore, the addition of glazing may significantly increase the cost over a commercial building. However, worker productivity benefits may still outweigh these costs.

3-3.2 Controls. Lighting controls have the benefit of reducing energy use when lighting is not required. However, the cost of the control device increases the initial system cost. For most applications, typical energy savings pay for control devices in approximately 3-7 years. The time period may be less when worker satisfaction is considered. This payback makes lighting control an attractive energy saving strategy. It is important to note that electric lighting controls must be incorporated with a daylight design to gain any energy savings from the daylight.

3-3.3 Energy Efficiency. The careful selection of light sources to utilize the most efficient and lowest wattage light source for the application reduces energy use and cost. This results in a significant benefit with a low cost increase. The increase in lamp cost between incandescent sources and more efficient, longer life, fluorescent sources is typically paid back in energy savings and replacement costs within a few years.

3-3.4 Materials. The mercury content of fluorescent and HID light sources poses a significant environmental threat when sent to a landfill or incinerator. By law, commercial and military facilities must recycle these lamps. This cost must be

considered when developing a life-cycle cost analysis.

3-3.5 Light Pollution / Light Trespass. Light pollution and trespass are reduced with the selection and location of lighting equipment. The benefit of addressing this issue is increased visibility and a minimal impact on the night sky. There is not necessarily an associated increase in cost. Shielded and full cutoff luminaires are not necessarily more expensive than non-cutoff luminaires. When considering glare and veiling luminance criteria in addition to illuminance criteria, more luminaires may not be necessary. Designing to minimize light pollution and trespass encourages minimizing the amount of equipment and avoiding overlighting exterior areas. Both of these aspects may reduce initial cost.

3-4 **UTILIZING DAYLIGHT.** The introduction and control of daylight into interior spaces has a twofold benefit. It can reduce the amount of energy that is necessary to light interior spaces and it also has a significant effect on the indoor environmental quality for the occupants.

3-4.1 Daylight is a reliable and efficient light source. When properly controlled, it can provide quality and adequate light levels without becoming a source of glare or overheating a space. Architectural shading devices including overhangs and canopies can provide sufficient ambient light while eliminating direct glare. Chapter 4, “Daylighting”, discusses strategies and technical details for successfully providing daylight to achieve these goals.

3-4.2 The introduction of daylight into interior spaces has a well-documented effect on the productivity of occupants and the education of students. In a study done by the Heschong Mahone Group³, students who worked in daylighted classrooms progressed 26% faster on reading exams and 20% faster on math exams than students working in a classroom with less daylight.

3-4.3 Daylighting strategies can be divided into passive or active systems. Passive systems are the most common and refer to the location, profile, orientation, and shading of glazing on a building. Optimizing these components results in a building that admits daylight without excessive heat gain or glare. Because all of the devices and components are stationary, these techniques are categorized as passive. In comparison, active daylighting systems have moving parts, typically to track the sun throughout the day. An example of an active system includes a skylight with a moving mirror that captures direct sunlight and redirects it through the skylight, into the building.

3-5 **LOW ENERGY USE.** Energy efficiency in buildings necessitates a holistic approach to the design of the building systems and the integration between systems. The American Society of Heating, Refrigeration, and Air-conditioning Engineers (ASHRAE) and the IESNA have produced ASHRAE / IESNA 90.1. This document addresses efficiency standards that must be met for minimum energy performance.

³ The Heschong Mahone Group, “Daylighting in Schools”, <<http://www.h-m-g.com/Daylighting/summaries%20on%20daylighting.htm#Daylighting%20in%20Schools>>

3-5.1 Efficacy refers to the amount of light (lumens) that is produced by a light source for every watt of energy. Different light sources produce light at different efficacies. Incandescent lamps have the lowest efficacy while fluorescent, induction, and metal halide sources have highest efficacies. Efficacy must be considered along with the application to select the most efficacious source that will light the surface or task appropriately.

3-5.2 Efficacy is often the focus of energy efficiency in lighting systems. While this is important, it is not the only strategy for reducing energy consumption. As described in the Surface Brightness, Task / Ambient, and Controls sections of Lighting Design Considerations, what the lighting design illuminates, how it is layered into separate systems, and how it is controlled (in response to daylight and occupancy) all affect the energy consumption. Increasing surface brightness can reduce the amount of energy necessary to light a space. Dividing the lighting system into task and ambient components allows the ambient system to use less lighting energy and an increase in light levels is provided only where it is required: at the task, not throughout the entire space. By controlling these lighting components separately, only the energy that is required at any given time is consumed.

3-6 MATERIAL ISSUES

3-6.1 Mercury Content. Fluorescent, metal halide, and high-pressure sodium lamps contain liquid mercury to produce the mercury vapor necessary for lamp operation. When lamps are broken or incinerated the mercury may be released into the soil or the atmosphere. Mercury has been linked to potential health risks. Some lamp manufacturers offer product series that feature reduced mercury content.

3-6.2 Recycling. All lamp types except incandescent sources contain some level of mercury. These lamps should be recycled to avoid release of any mercury into landfills. The cost of recycling lamps should be included in any life-cycle cost analysis.

3-6.3 Lamp Life. The life expectancy data given by lamp manufacturers refers to the approximate time at which 50% of the lamps in a group are no longer operating. The life of standard incandescent and tungsten halogen sources can be extended by dimming them 5% - 10%. Frequent switching of fluorescent sources can reduce the lamp life. However, the use of rapid start or programmed ballasts reduces the impact of frequent starting on the lamp life. Recent developments in lamp technology have introduced long life lamps that have four to five times the life of standard incandescent lamps. Examples include LED and induction lamps with useable lives of 50,000-70,000 hours.

3-7 **LIGHT POLLUTION.** Light pollution or sky glow is caused by light aimed directly up into the sky and by light reflected off the ground or objects. Sky glow prevents the general public and astronomers from seeing the stars.

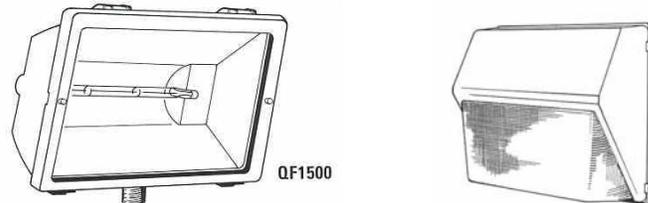
3-7.1 Floodlights, wall packs and other un-shielded luminaires are the major contributors to sky glow. Overlighting, even with shielded luminaires, reflects unnecessary light back into the atmosphere and adds to the sky glow. This often

occurs at outdoor areas such as motor pools and sports fields.

Figure 3-1. Los Angeles, 1908 (left), Los Angeles, 1976 (right)

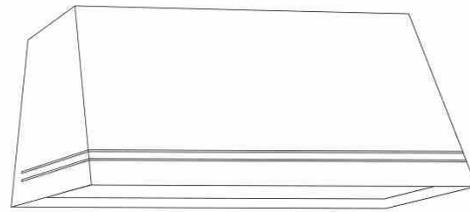


Figure 3-2. Unshielded and non-cutoff luminaires lead to light pollution.



3-7.2 To minimize light pollution, use fully shielded luminaires or IESNA full cut-off type for area and roadway lighting as illustrated in Figure 3-3. The use of full cutoff luminaires may reduce uniformity and therefore require greater pole heights or spacing. Cutoff, semi-cutoff, and non-cutoff luminaires may also be used at low mounting heights if the lumen output of the lamp is limited to 4200 lumens. These applications, such as pedestrian and entry lighting, typically require greater vertical illuminance for facial identity. For a more detailed description of full-cutoff, and cutoff luminaires, see Table 5-2 in Chapter 5, "Lighting Equipment". Provide uniform low glare lighting and do not overlight exterior areas. Also, control lighting with time clocks, photocells, and motion sensors such that lighting is only energized when needed.

Figure 3-3. Examples of IESNA full cut-off luminaires.



3-8 **LIGHT TRESPASS.** Light trespass is referred to as nuisance glare or the “light shining in my window” effect. It is usually caused by a glare source that is bright compared to the darker night surround. Since glare inhibits our ability to “see” tasks and decreases contrast, all designs must minimize glare.

3-8.1 Uncontrolled light sources (floodlights) are usually the cause of light trespass. Not only does light trespass cause neighbor annoyance, but it also increases light pollution.

Figure 3-4. Glare results in loss of visibility.



3-8.1.1 To minimize light trespass, use only fully shielded or IESNA full cutoff luminaires for area lighting. When unshielded luminaires such as wall packs and decorative luminaires are used at low mounting heights, reduce the lamp brightness to that of a 4200 lumen lamp (similar to a 55 watt induction lamp) or less. Do not overlight areas because reflected light can also result in complaints and poor visibility by increasing visual adaptation. Also, consider dimming or turning lighting off when not needed and activate with motion sensors or timers when activity occurs.

Figure 3-5. Fully shielded or IESNA full cut-off luminaires (left) are recommended. Do not use unshielded floodlights (right).



3-9 ECONOMIC ISSUES. The economic benefits of sustainable building strategies may not be immediately obvious until a life cycle cost estimate is evaluated. Various methods and programs can provide a life cycle cost for different building systems. The Federal Energy Management Program (FEMP) provides technical assistance for these methods.

3-9.1 Some strategies require no additional initial cost. Others may require a higher initial cost, but will often payback that cost increase within a few years. Some initial costs may provide for savings in other systems resulting in no net increase in the overall building cost. For example, skylights, shading devices, and lighting controls may increase the cost of the lighting and glazing systems, but it may result in a downsizing of the mechanical system and mechanical space required.

3-9.2 Not all economic issues are included in a life cycle cost. For example, the economic benefits of improved productivity in more comfortable daylighted buildings are not easily quantified. Additionally, energy efficiency reduces energy costs but also avoids the cost of externalities of energy production. Externalities are costs of energy production that are not included in the cost of the energy. Such externalities include costs of cleaning up pollution generated by a coal mine and a coal fired power plant. Other examples may include healthcare costs resulting from pollution-related illnesses.

3-10 RETROFITTING.

3-10.1 Many existing lighting systems can be retrofitted with new technology to provide appropriate lighting. Consider luminaires in good condition, whether relocated or salvaged, an alternative to new lighting equipment when retrofitted with efficient technology. This may be a more cost effective solution to energy efficiency than new construction.

3-10.1.1 Retrofitting requires appropriate design analysis to ensure that acceptable results will be achieved. Redistribution of light should only be accomplished based upon sound design principles. Specular reflectors and parabolic retrofits should only be

used after testing and system design is accomplished. The following paragraphs provide typical retrofit possibilities; however, it is stressed that lighting design changes require proper evaluation on a case-by-case basis.

3-10.2 Existing Troffer Systems.

3-10.2.1 Typical Installations. Convert T-12 lighting systems to T-8 lamps and electronic high frequency ballasts. In most cases, de-lamp 4-lamp luminaires to either 2- or 3-lamps. White painted reflectors should be installed in older parabolic troffers. Install new lenses in lensed troffers if existing lenses are more than 7 years old.

3-10.2.2 T-12 fluorescent lamps come in a nominal 4 ft (1.2 m) length and are therefore suitable for retrofit with T-8 lamps. T5 and T5HO lamps are a metric length and slightly shorter than T-12 and T-8 lamps. These lamps cannot be supplied in place of the 4 ft (1.2 m) lamps and also may not be an appropriate brightness. Luminaires need to be specifically designed for use with T5 and T5HO lamps to control the brightness.

3-10.2.3 Special Considerations for Computer Intensive Workspace. Most lensed troffers are not suited for computer workspaces. Consider relighting with a direct/indirect or semi-indirect pendant system.

3-10.3 Existing Downlights.

3-10.3.1 Typical Installations. Remove the incandescent lamp and socket, and install a hardwired compact fluorescent adapter using a standard plug-based compact fluorescent lamp. In many cases, replacement of the reflector is also required to efficiently utilize the compact fluorescent lamp. Compact fluorescent lamp watts should be about 25 percent to 30 percent of original incandescent lamp watts to achieve similar light levels.

3-10.3.2 Atypical Installations. In some cases, hardwired conversions can be difficult or not cost effective. Use a medium based adapter with integral ballast and replaceable compact fluorescent lamp. Compact fluorescent lamp watts should be about 25 percent to 30 percent of original incandescent lamp watts to achieve similar light levels. These systems normally cannot be dimmed.

3-10.4 Existing Fluorescent Industrial Luminaires, Wraparounds, and Strip Lights.

3-10.4.1 Replace F40T12, and F48T12 lamps and magnetic ballasts with T-8 lamps and electronic high frequency ballasts.

3-10.4.2 For lighting systems employing F96T12 slimline and F96T12/HO lamps, consider all of the following:

- Retrofitting with electronic high frequency ballasts and continuing to use existing lamps.
- Replacing 2.4 m (8 ft) lamps with 1.2 m (4 ft) T-8 lamps, possibly including

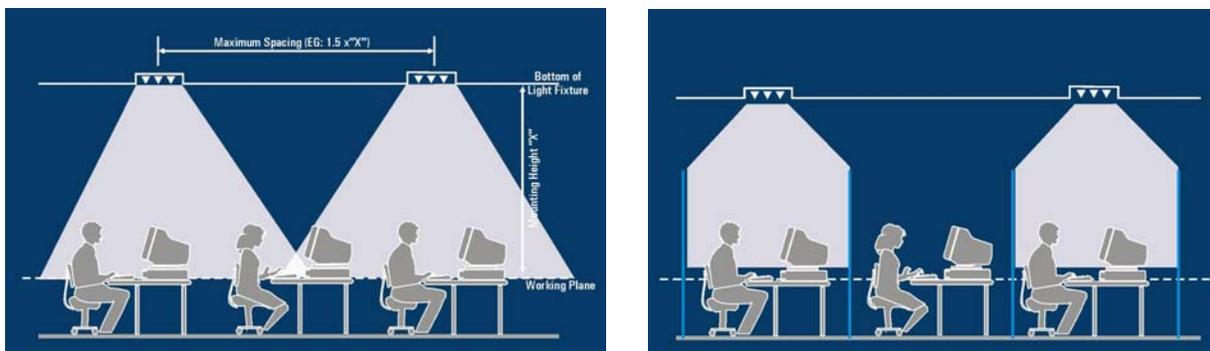
high light output ballasts and high output T-8 lamps when replacing T12/HO lamps.

- Replacing 2.4 m (8 ft) lamps with T-8 2.4 m (8 ft) lamps and electronic high frequency ballasts.

3-10.5 Maintaining Uniformity. Carefully consider changes in lighting systems and furniture systems so that lighting uniformity is not compromised. As shown in Figure 3-6, a lighting system that provides uniform illuminance on the work-plane in one furniture configuration may not provide the same uniformity in a different configuration.

3-10.5.1 In the case shown, an additional luminaire is required to adequately light the center workstation. This increases the amount of energy required to light the same area. In such a condition, the use of a semi-indirect, pendant system will provide better uniformity and at the same time allow for flexibility in the workstation layout.

Figure 3-6. A change in furniture configuration affects the task plane illuminance uniformity.⁴



3-10.6 Low Ceiling Applications.

3-10.6.1 In some applications, the ceiling height may be low and cannot be increased to accommodate pendant mounted lighting equipment. In these cases, the lighting design should still try to address the issue of surface brightness. One way to achieve surface brightness with low ceiling conditions is with recessed downlight / wallwash luminaires. The reflector on these luminaires looks similar to a standard downlight, but also uses a modification to light adjacent walls evenly. It is also designed to put light high on the wall next to the ceiling.

3-10.6.2 Indirect lighting provides better visibility for offices and computer tasks than parabolic luminaires. Additionally, the installation cost of pendants can be lower than recessed troffer luminaires due to the reduced number of connection points. In low ceiling applications where a semi-indirect pendant system is not feasible, consider semi-specular parabolic troffers for lighting the interior of the space. Downlight / wallwashers

⁴ Used with permission. Hayden McKay Lighting Design.

around the perimeter of the space increase the surface brightness of the walls. This strategy is a better choice to eliminate glare than the use of lensed troffers.

3-10.6.3 Semi-indirect pendant manufacturers are also developing short pendant luminaires for low ceiling applications. These luminaires will use refined optics to spread light out and light the ceiling with a pendant length of under 0.3 m (12 ft). These luminaires will allow semi-indirect lighting systems in spaces with a ceiling height of 2.4 m (8 ft).

3-10.7 Existing HID Industrials, Floodlights, Downlights and Other Luminaires.

3-10.7.1 Replace mercury vapor lighting systems with one of the following approaches:

- Replace mercury vapor lamps with compatible metal halide or induction lamps, especially if increased light levels are required.
- For interior high bay applications, replace with a linear fluorescent system. This replacement is especially appropriate for applications where switching or dimming could be encouraged to save energy in addition to improving visibility. Fluorescent retrofits are not a one-for-one replacement of HID luminaires but rather an alternate lighting system.

3-10.8 Existing Exit Signs.

3-10.8.1 Incandescent exit signs should be retrofitted with LED exit signs. Because of 1996 revised UL listing requirements for exit signs, consider replacing exit signs with all new LED signs.

CHAPTER 4

DAYLIGHTING

4-1 **BENEFITS OF DAYLIGHT.** Daylight in interior spaces has multiple benefits. Daylighted environments provide a connection to the outdoors, are healthier for occupants and have the potential to save energy. Research has shown that children learn better¹, retail stores sell more product², and office workers are more productive^{3 4} in daylighted environments. Since daylight also helps to regulate our circadian cycle⁵, introducing daylight into interior spaces is a top priority. Daylight is a natural resource that is more efficient than electric light and should be utilized to its fullest potential (Refer to Chapter 5, "Lighting Equipment" for efficacy of light sources).

4-2 **PROJECT TYPES THAT BENEFIT FROM DAYLIGHT.** The introduction of daylight into any space has the potential to provide these benefits for the occupants as well as reduce building energy use. However, some project types are better suited than others to take advantage of daylight.

4-2.1 Open spaces with high ceilings such as hangars, warehouses, recreation centers, and maintenance areas offer good opportunities for toplighting with skylights and clerestories.

4-2.2 Perimeter spaces such as offices, lobbies, classrooms, cafeterias, and residential areas are all good sidelighting applications.

4-3 **DAYLIGHTING ECONOMICS.** The use of daylight can produce more comfortable work environments. This benefit may be difficult to quantify, but the energy saved by dimming or switching electric light in response to daylight can be quantified. The implementation of skylights and clerestories as well as lighting control equipment such as dimming ballasts and photocells all increase initial cost. Additionally, for DoD facilities in areas of high threat, Antiterrorism (AT) criteria (see UFC 4-010-01) increase the required strength of all glazing. Therefore, the addition of glazing may significantly increase the cost over a commercial building. Careful analysis must consider these costs to determine the payback of daylighting strategies. The following case studies describe projects where daylighting strategies and energy efficient lighting and controls have been added to an existing building.

¹ The Heschong Mahone Group, "Daylighting in Schools", <<http://www.h-m-g.com/Daylighting/summaries%20on%20daylighting.htm#Daylighting%20in%20Schools>>

² The Heschong Mahone Group, "Skylighting and Retail Sales", <[http://www.h-m-g.com/Daylighting/summaries%20on%20daylighting.htm#Skylighting and Retail Sales](http://www.h-m-g.com/Daylighting/summaries%20on%20daylighting.htm#Skylighting%20and%20Retail%20Sales)>

³ California Energy Commission. (2003). *Windows and Offices: A study of office worker performance and the indoor environment* (Catalogue No. P500-03-082-A-9).

⁴ "Design Objectives, Productive", *Whole Building Design Guide*, 22 August 2002 <<http://www.wbdg.org/design/index.php?cn=2.6&cx=0>>

⁵ New Buildings Institute, Inc. "Lighting and Human Performance", *Advanced Lighting Guidelines*, Chapter 2. 2001 Edition, p.2-12-13

4-3.1 Philip Burton Federal Building⁶ ⁷. This lighting control retrofit project incorporated advanced lighting controls and daylight sensors for 16,720 m² (180,000 square feet) of the 20-story Philip Burton Federal Building in San Francisco. When adequate daylight entered the space, unnecessary lighting was turned off. Energy savings ranged from 30% to 41% for zones of luminaires nearest the windows and 16% to 22% for interior zones of luminaires. Using this type of control equipment, the payback for equipment ranges from 4.7 to 6.4 years.

4-3.2 California State Automobile Association⁸. In this renovation, skylights with automatic louvers control the amount of light entering the building based on the amount of available daylight. Barometric exhaust vents in these skylights release heat gain from the skylight wells. Dimmable electronic ballasts raise and lower the electric lighting based on the amount of light in the space. High performance windows and manual shades were also utilized. Overall lighting energy use was reduced by 32% with these strategies.

4-4 **SYSTEM INTEGRATION.** If the majority of areas are daylighted, then the electric lighting becomes supplemental during daytime periods. Since our appetite for light is less in the evening and nighttime hours, daylighting does not need to be duplicated with electric lighting. Design electric lighting to supplement the daylighting. For example, when daylight is plentiful, the electric lighting could be dimmed near the daylight source. In other areas where the daylight penetration is not as great, the electric lighting can be increased. Electric lighting controls (daylight and occupancy sensors) can typically save up to 50% of the lighting energy in existing buildings and up to 35% in new buildings⁹.

4-4.1 Requirements for system integration:

- Electric lighting must be dimmed, switched, or controlled in response to daylight availability. Do not attempt to duplicate daylight with electric light – supplement it.
- Commission controls to maximize and tune energy benefit.

4-4.2 Considerations for system integration:

⁶ "Philip Burton Federal Building", *Pacific Gas and Electric Company*, Daylighting Initiative, 1999, <http://www.pge.com/003_save_energy/003c_edu_train/pec/daylight/di_pubs/1487Gate_repaginated.pdf>

⁷ Rubinstein, Francis; Jennings, Judith; Avery, Douglas; "Preliminary Results from an Advanced Lighting Controls Testbed", Ernest Orlando Lawrence Berkeley National Laboratory, Berkeley, CA, March 1998 <<http://eetd.lbl.gov/btp/papers/41633.pdf>>

⁸ "California State Automobile Association Office", *Pacific Gas and Electric Company*, Daylighting Initiative, 1999, <http://www.pge.com/003_save_energy/003c_edu_train/pec/daylight/di_pubs/1487CSAA_repaginated.pdf>

⁹ New Buildings Institute, Inc. "Lighting Controls", *Advanced Lighting Guidelines*, Chapter 8. 2001 Edition, p. 8-1.

- Control the electric lighting in response to the daylight by dimming it in task oriented areas such as offices, conference rooms, classrooms or turning it off in non-task areas such as circulation and lounge areas.

4-5 **MAXIMIZE DAYLIGHT POTENTIAL.** Building orientation, views, side and top lighting, shading devices, and selective glazing are all critical to maximizing daylight potential. All of the following recommendations are for the northern hemisphere. In the southern hemisphere, recommendations regarding north and south orientations are reversed. Also, interior spaces should have high ceilings and light reflective surfaces to allow deep daylight penetration. Provide architectural and manual shading devices for daylight and view windows. In areas of high threat, lightshelves tend to be discouraged because of blast mitigation. These objects can become additional projectiles during a blast. Refer to the Whole Building Design Guide, *Balancing Security/Safety with Sustainability Objectives*, <http://www.wbdg.org/design/resource.php?cn=0&cx=0&rp=28>.

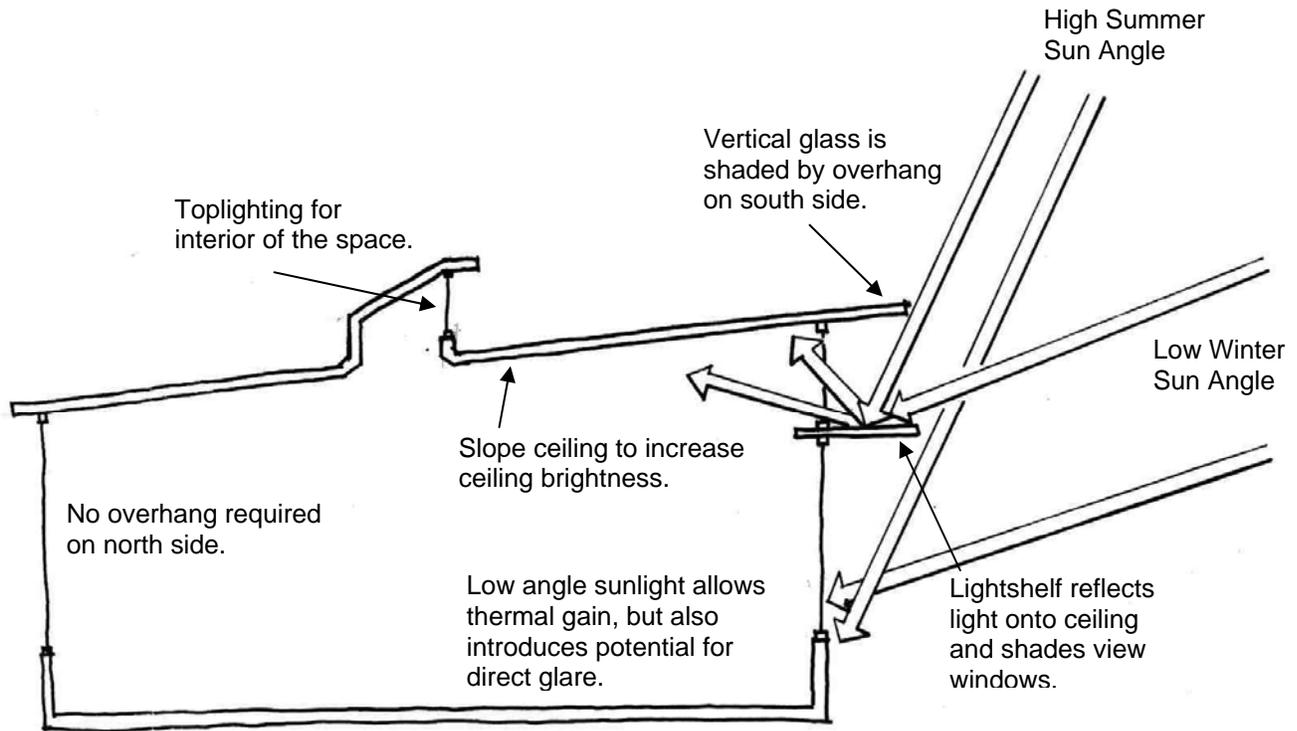
4-5.1 Over 60% of existing square footage of interior spaces (within the US) has access to roofs for top-lighting and 25% of existing national square footage has access to side-lighting.¹⁰

4-5.2 Considerations to maximize daylight potential:

- Maximize view windows on the north and south facades.
- Provide high ceilings to allow deeper daylight penetration.
- Bring daylight high into the space to maximize penetration.
- Where possible, consider external light shelves to provide shading for view windows.
- Where possible, consider internal light shelves to provide shading for clerestories and also a surface for reflecting light onto the ceiling.
- Provide separate shading devices for daylight windows and view windows.
- Utilize selective glazing to maximize visible transmittance (high T_{vis}) and minimize solar radiation (low shading coefficient).
- Use high reflectance values on ceiling and wall surfaces to balance out the daylight.
- Avoid daylight barriers such as solid walls near the building perimeter.
- Use clerestory and transom glazing to share daylight from perimeter windows to interior spaces.

¹⁰ Heschong, Lisa, "Daylighting Workshop", Pacific Energy Center, (March 2003).

Figure 4-1. Examples of daylighting Strategies.



4-6 **GLAZING ORIENTATION.** Building orientation is critical to maximizing daylight potential. North- and south-facing buildings provide the most effective orientations while East- and West-facing buildings may allow excessive heat gain and are hard to control direct sun penetration. South orientations have the potential of providing over 50% of the daylight. The success to daylighting with south orientations is controlling the direct sunlight penetration with shading devices. North orientations require minimal shading in the winter months. East and West orientations require manual shading devices. Vertical blinds control daylight well on this orientation.

Figure 4-2. Building orientation can maximize daylight exposure.

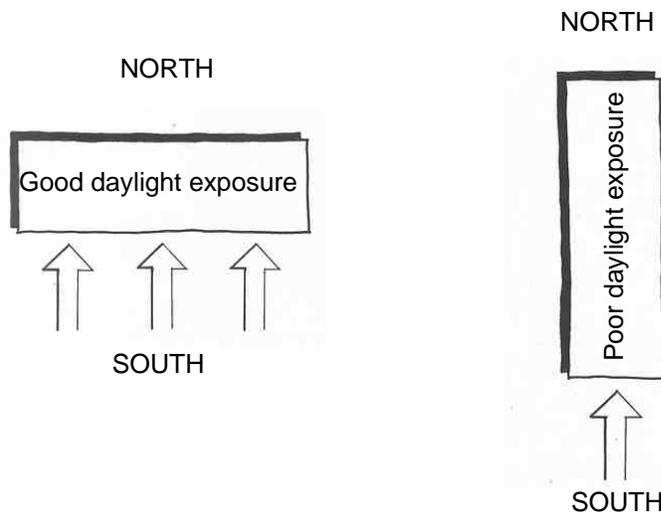


Figure 4-3. Example of architectural shading devices.



4-6.1 Considerations for orienting glazing:

- Orient building to maximize north and south exposures.
- North facing windows provide the most even illumination.
- If orientation is off-axis from north and south, provide shading devices for south-east and south-west exposures.
- Provide architectural shading devices for south orientations.
- Provide manual shading devices for south orientations. Horizontal blinds best control the high angle light on southern exposures.
- Provide manual shading devices for east and west orientations. Vertical blinds best control the low angle light on east and west exposures.

4-7 **GLAZING CHARACTERISTICS.** Use selective glazing to optimize and tune glass based on its purpose and use (clerestory or vision). Clerestory glass may require high visibility transmittance without color distortion while minimizing infrared penetration.

4-7.1 Considerations for glazing characteristics:

- Maximize glazing transmittance (T_{vis}) for daylight glazing (.70 or greater) for clerestories and other daylight fenestrations.
- Although the visible transmittance selected depends on personal preference, typically, use T_{vis} values in the medium range for view windows (.40 or greater).

- Minimize infrared transmittance by specifying a moderate to low shading coefficient (SC) or low solar heat gain coefficient (SHGC) (50% or lower)¹¹.
- Use high transmittance glazing greater than 60% to maximize daylight. Glazing should also have a high thermal resistance ratio in order to minimize heat gain.
- Use clear glazing. Do not use tinted or mirrored coatings.

Table 4-1. Comparison of glass types. (from AlpenGlass Heat Mirror)

Sample Glass Types	Total Daylight Transmittance %	Solar Heat Gain Coefficient
Clear Double Insulating Glass (1/8" thick)	81	0.75
Laminated Glass (1/2" clear)	85	0.72
HM 88/Clear	72	0.57
HM SC75/Clear	62	0.36
HM 55/Clear	47	0.30

4-8 **QUANTITY OF GLAZING.** Through simple tools and modeling, glazing quantities can be optimized in order to provide maximum daylight potential while minimizing economic costs. Bring daylight in high through clerestories and top-lighting, yet provide view windows for occupant benefits. Also, bring daylight in from two directions if possible for balanced, uniform lighting.

4-8.1 Toplighting optimization varies between 3% and 9% skylight to floor area ratio.¹² The optimal amount of toplighting area factors in daylight contribution, cooling loads, and potential energy savings. In order to calculate toplighting area optimization, use a calculation program similar to "SkyCalc"¹³. Sunny climates with a cooling load dominated environment will require less toplighting area than a cooler overcast climate¹⁴.

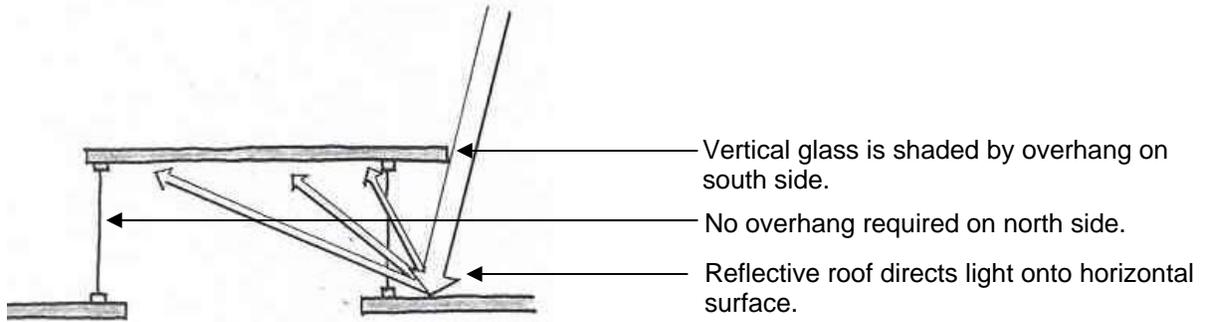
¹¹ Ernest Orlando Lawrence Berkeley National Laboratory, "Glazing Selection", *Tips for Daylighting with Windows, The Integrated Approach*, Section 4, p. 4-1.

¹² New Buildings Institute, Inc. "Luminaires and Light Distribution, Daylight Systems", *Advanced Lighting Guidelines*, Chapter 7. 2001 Edition, p. 7-31

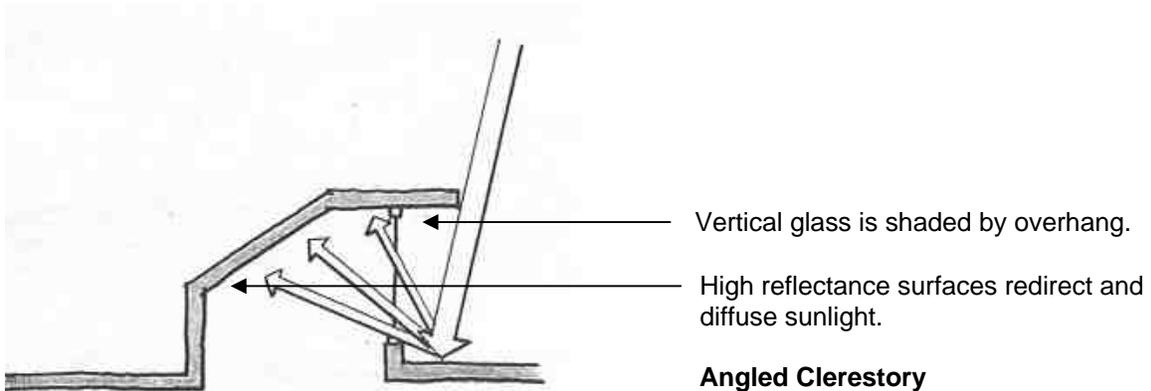
¹³ The Heschong Mahone Group, "Optimizing Your Design", *Skylighting Guidelines*, Chapter 1, 1998, pp. 1-1-5-7.

¹⁴ The Heschong Mahone Group, "Optimizing Your Design", *Skylighting Guidelines*, Chapter 5, 1998, pp. 5-12-13.

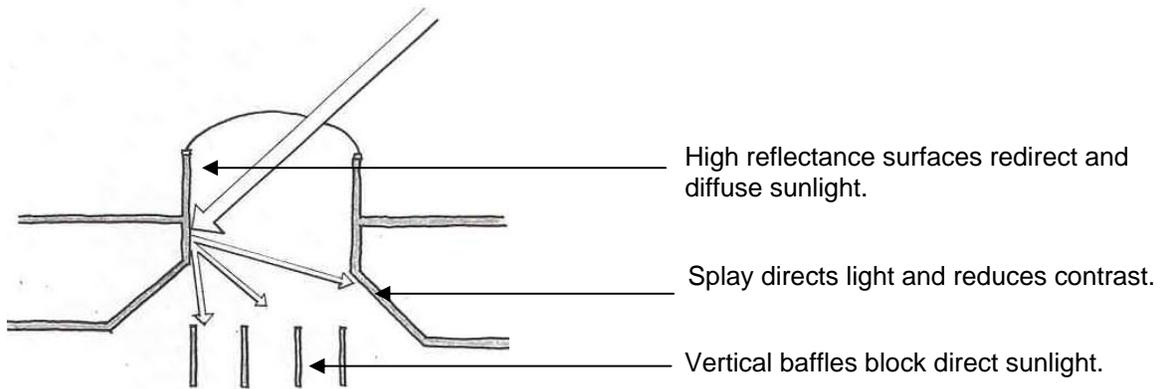
Figure 4-4. Diagrams of toplighting strategies.



Roof Monitor



Angled Clerestory



Horizontal Skylights with Splay

Figure 4-5. Examples of toplighting applications.



Figure 4-6. Example of clerestory application.



Figure 4-7. Examples of sidelighting applications.



4-8.2 Considerations for quantity of glazing:

- Sidelighting windows should be located as high as possible since effective daylight penetration from windows is 1.5 times the height of the window¹⁵.
- Use high continuous clerestories for the deepest daylight penetration and uniformity.
- In order to provide exterior views, provide glazing at eye level.
- Use view windows that have minimal wall area between windows. Avoid small windows located in large wall areas because of the uncomfortable contrast and glare that result¹⁶.
- 0.09 m² (1 sq ft) of top lighting can provide illumination to about 10 times the area that Sidelighting provides yet does not provide the view¹⁷.
- Space top lighting apertures approximately one and a half times the ceiling height for even illumination. Recess and splay (45° to 60°) skylights to minimize glare¹⁸.
- Toplighting systems located at least 1.5 times the mounting height on center can provide even daylight distribution.¹⁹

¹⁵ US Department of Energy, Energy Efficiency and Renewable Energy, "Sidelighting vs. Toplighting", *National Best Practices Manual, Daylighting and Windows*, p. 73.

¹⁶ New Buildings Institute, Inc. "Luminaires and Light Distribution, Daylight Systems", *Advanced Lighting Guidelines*, Chapter 7. 2001 Edition, p. 7-35.

¹⁷ US Department of Energy, Energy Efficiency and Renewable Energy, "Toplighting", *National Best Practices Manual, Daylighting and Windows*, p. 75.

¹⁸ US Department of Energy, Energy Efficiency and Renewable Energy, "Design Details", *National Best Practices Manual, Daylighting and Windows*, p. 101.

¹⁹ The Heschong Mahone Group, "Designing with Skylights", *Skylighting Guidelines*, Chapter 2, 1998, pp. 2-5.

- Skylight area should be between 2% to 9% of the floor area depending on the climate optimization

4-9 **GLARE AND CONTRAST CONTROL.** Glare and excessive contrast occur when side and top lighting devices allow direct sunlight penetration. Quality daylighting allows skylight and only reflected sunlight to reach the task. Punched openings also can cause uncomfortable contrast ratios.

Figure 4-8. Examples of roof shapes.



Figure 4-9. Examples of played skylights.



4-9.1 Considerations for controlling glare and contrast:

- Provide external and internal shading as described in paragraph 4-1.
- Utilize top-lighting systems with vertical glazing to control direct radiation.
- If horizontal glazing is designed for top lighting systems, then provide played openings or translucent shielding below the skylight in order to minimize the contrast.
- Avoid punched windows; use continuous or mostly continuous side lighting.
- Use high reflectance surfaces for ceiling and walls (80% or greater for

ceilings and 50% or greater for walls)²⁰.

4-10 **ACTIVE DAYLIGHTING.** Active daylighting strategies and devices utilize a mechanical component to collect and distribute daylight. Such devices differ from the passive strategies that have previously been discussed which are stationary. The example shown in figure 4-10 turn a series of reflectors as the sun moves throughout the day. These reflectors catch the direct sunlight and redirect it through the skylight.

4-10.1 Such devices add extra initial cost and also pose additional maintenance issues. However, they also can make use of daylight for a longer period of time throughout the day. With tracking devices, effective daylighting can begin earlier in the morning and last later in the day than with stationary skylights. Careful evaluation of the lifecycle cost and the energy savings must be considered.

Figure 4-10. Example of an active daylighting system that tracks the sun and directs daylight into the building.



4-11 **PHYSICAL MODELING.** Daylight levels depend on many factors such as window shapes, orientation, shading, and time of day. Therefore, physical models built to scale can provide information on light quality, shade, shadows, and actual light levels. By building the model with the actual proposed materials and orienting it with adjustments for latitude, season, and time of day, the light quality can be seen in the model. Such models inform the designer about quality issues including light patterns, shade, shadows, contrast, and penetration in the space. An illuminance meter inside the model will provide accurate predictions of expected light levels in the building.

4-12 **COMPUTER SIMULATION.** A wide range of software programs model the sun's path and its impact on building geometry in addition to how it affects heat gain and

²⁰ "Office Lighting", *Lighting Handbook Reference and Application*, Chapter 11, Ninth Edition (New York: The Illuminating Engineering Society of North America, 2000), p. 11-2.

energy use. In using any of the software, the designer must be aware of its limitations and assumptions, as well as the variables under the users' control. These tools provide a prediction of how building components will behave throughout changing conditions. They do not provide actual light levels or energy use. The following web sites detail the features of some of these programs and their applications.

- US Department of Energy – Energy Efficiency and Renewable Energy Building Tools Directory:
http://www.eere.energy.gov/buildings/tools_directory/
- Whole Building Design Guide Energy Analysis Tools:
<http://www.wbdg.org/design/resource.php?cn=0&cx=0&rp=13>

CHAPTER 5

LIGHTING EQUIPMENT

5-1 BUDGET CONSIDERATIONS.

5-1.1 Selecting Equipment.

5-1.1.1 Select luminaires based on application suitability, performance, aesthetics, and initial cost.

5-1.1.2 Select lamps based on the application, energy consumption, low maintenance, life, and replacement costs. One source for determining costs is the Defense Logistics Agency (DLA). (See Appendix A for contact information.)

5-1.1.3 Select ballasts based on energy consumption, low maintenance, and life.

5-1.1.4 Select controls based on the application, low maintenance, reliability, and life.

5-1.2 Life cycle cost analysis. There are many economic factors that need to be considered when designing a lighting system. Life cycle costs include initial costs (equipment procurement and installation), energy, and maintenance costs. Additional issues involve the impact of lighting on productivity. These costs are currently not represented in the life cycle cost analysis, but have been estimated for the total Federal sector at \$17.65/m² (\$1.64/SF per year)¹. Since this is a significant factor, quality lighting decisions cannot be undervalued.

5-1.2.1 Initial costs: Estimate equipment quantity and unit pricing for luminaires, lamps, ballasts and controls. Also estimate the labor cost. Do not use a percentage of initial costs because this can be misleading. For example, installing direct/indirect linear fluorescent pendants may be less labor since they require only one point of electrical connection, versus individual recessed lay-in luminaires. The cost of quality lighting equipment is very economically competitive. The Defense Logistics Agency (General and Industrial Lighting) can be contacted for cost estimates of lighting equipment.

5-1.2.2 Energy costs: Energy costs should take into account not only the connected lighting loads, but also the actual loads due to daylight and manual dimming, occupancy sensors, and energy management systems. Peak power demand in most climates occurs during the sunniest days when daylight is the most available. If the peak demand can be lowered through controls, then the energy costs can be considerably lower.

5-1.2.3 Maintenance costs: Life and reliability of the lighting equipment are inherent in maintenance costs. In addition, replacement procurement and installation costs are

¹ "Economics of Energy Effective Lighting for Offices", *Federal Energy Management Program (FEMP) Lighting Resources*, <<http://www.eere.energy.gov/femp/resources/economics.html>>

factored into the formula. Group re-lamping is always cost effective over spot re-lamping. Lamps that are reliable and need replacement every several years (versus months) need to be specified. In addition, specify compatible equipment. For example, when lighting is controlled with occupancy sensors, the ballast and lamp need to respond to this type of frequent control. Lamps that work well with occupancy sensors are rapid start and programmed start fluorescent and induction lamps. Instant start fluorescent and HID lamps are not compatible with occupancy sensors.

5-1.3 Energy Models: Even though energy efficient lighting reduces the building operating energy use, lower lighting energy also decreases HVAC loads. Decreased HVAC loads can represent initial cost savings. Energy models should be performed for each building to estimate the impact of daylighting, building envelope design, energy efficient electric lighting, lighting controls, HVAC loads and controls. These models will best inform the designers on system wide decisions and the life cycle cost impacts.

5-1.4 Federal economic analysis: Refer to *FEMP Economics for Energy Effective Lighting for Offices* for life cycle cost analysis examples. Lighting system options have been calculated for open and small offices showing energy usage, illuminance levels, quality visual design factors, initial costs per square foot, annual operating costs per square foot, simple payback in years and Federal Savings to Investment Ratios.

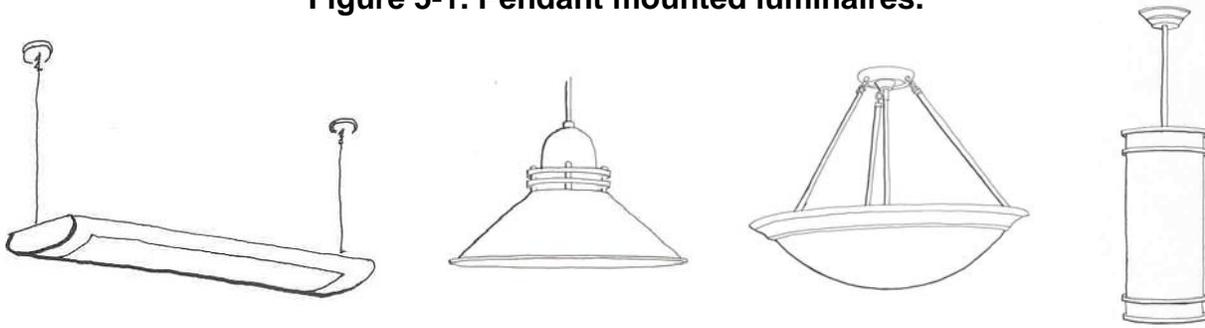
5-1.5 IESNA economic analysis: Chapter 25 “Lighting Economics” in the *Lighting Handbook* states multiple cost comparison methods. The Cost of Light calculates the unit cost of light per lamp using lamp efficacy, energy and replacement costs. Two other cost comparisons are explained including the Simple Rate of Return and more robust Life-Cycle Cost-Benefit Analysis.

5-2 **LUMINAIRES.** Luminaires are comprised of a light source (or lamp), reflector, shade, lens, refractor, mounting hardware and an electrical connection. Fluorescent and high intensity discharge luminaires include a ballast to operate the lamp. Induction luminaires utilize a generator and low voltage luminaires require a transformer. Since electric lighting consumes 20% to 25% of all electricity used in buildings and 5% of the total energy consumption in the United States², it is important to use energy efficient equipment.

5-2.1 Pendant Mounted Luminaires. Pendant mounted luminaires are suspended from the ceiling and may light down onto a table, uplight the ceiling, or provide a glow in all directions. Mount pendants at an appropriate height that will not result in a direct view of the source and provide adequate lighting levels. For example, in offices, linear fluorescent luminaires require sufficient ceiling height of 2.6 m (8 ft-6 in) or higher, although some newer T5 pendants are designed for 2.4 m (8.0 ft) ceilings.

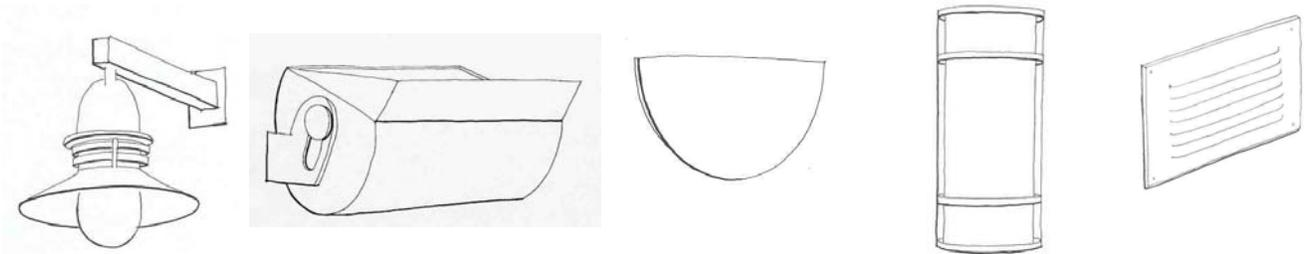
² “Energy Management”, *Lighting Handbook Reference and Application*, Chapter 26, Ninth Edition (New York: The Illuminating Engineering Society of North America, 2000), p. 26-1.

Figure 5-1. Pendant mounted luminaires.



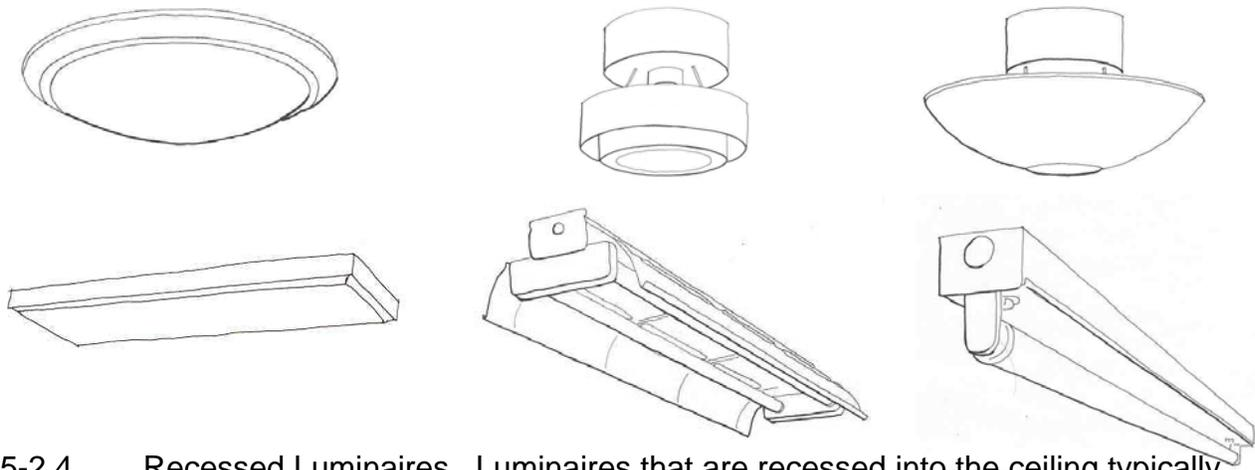
5-2.2 Wall Mounted Luminaires. Sconces or uplights may light the wall, ceiling, or provide a decorative glow. Steplights, often recessed into a wall, are located low on a wall can illuminate pathways and stairs.

Figure 5-2. Wall mounted luminaires.



5-2.3 Ceiling or Surface Mounted Luminaires. Ceiling or surface mounted luminaires provide a downlight and may also glow, depending on the type of housing and lens. Fluorescent luminaires are available in linear or compact versions. This type of luminaire is mounted directly to the ceiling. Lenses should adequately diffuse the light so as not to become a glare source and to prevent an image of the lamp from showing on the lens.

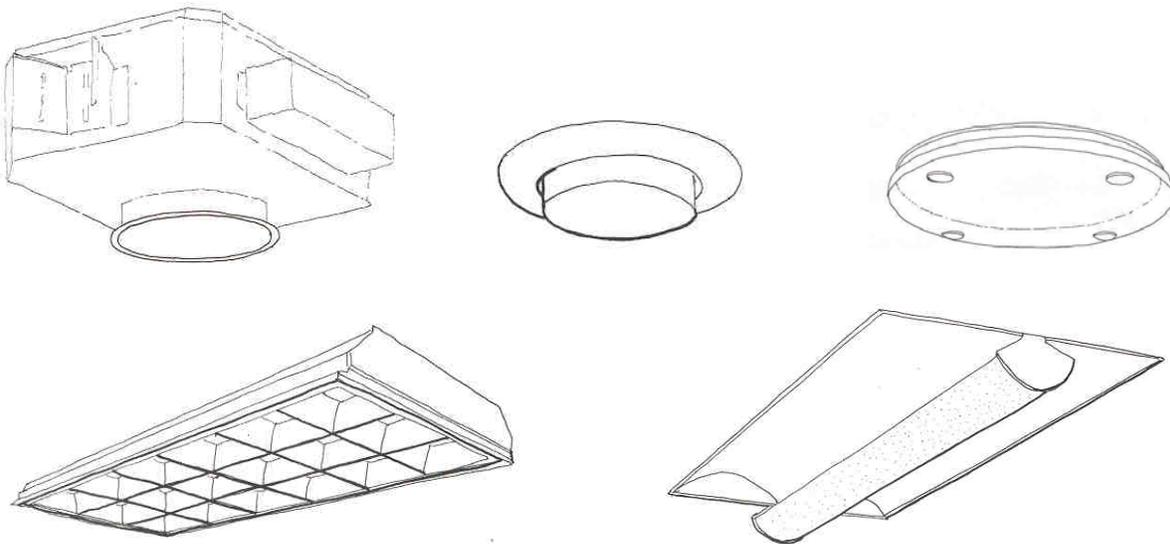
Figure 5-3. Ceiling / surface mounted luminaires.



5-2.4 Recessed Luminaires. Luminaires that are recessed into the ceiling typically light the horizontal surface below, or possibly an adjacent wall. These types of

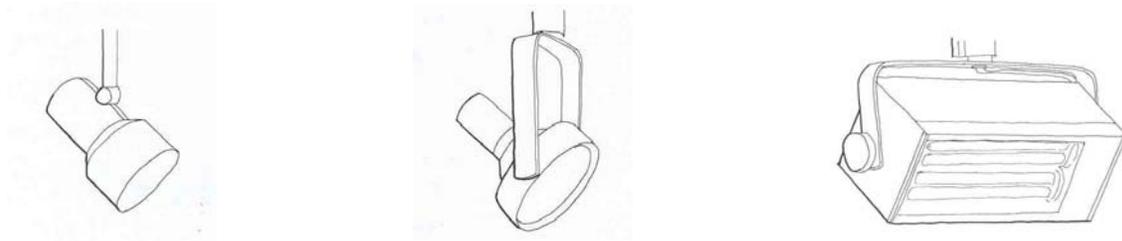
luminaires are often used for general ambient lighting. However, they are most appropriately used as task lighting or accent lighting / wallwashing. Semi-recessed luminaires use a lens or shade, dropped below the ceiling plane, to provide a decorative element as well as put some brightness on the ceiling. All recessed luminaires have a housing above the ceiling that contains the lamp and provides power. The housing must be suitable for the luminaire location. For example, in an insulated ceiling, the housing must be rated for contact with insulation or “IC” rated.

Figure 5-4. Recessed and semi-recessed luminaires.



5-2.5 Track Lighting. Track mounted luminaires are adjustable and can also be relocated along the length of track. These typically use tungsten halogen or low wattage metal halide directional sources especially appropriate for accent lighting. However, some track luminaires accommodate compact fluorescent lamps and are therefore more suitable for wall washing.

Figure 5-5. Track mounted luminaires.



5-2.6 Pole Mounted Exterior Luminaires. Pole mounted luminaires for exterior lighting come in a wide range of heights, but can generally be grouped in one of three categories: high mast luminaires, area luminaires on 7.6 – 12.2 m (25 -40 ft) poles, and pedestrian scale luminaires on shorter poles.

5-2.6.1 High mast luminaires light wide high traffic roadways such as interchanges. These luminaires should use IESNA full cutoff optics to eliminate glare. Additional shielding may be required to avoid light trespass.

5-2.6.2 Area luminaires light roads, parking lots, storage areas, and depots. Mount on 7.6 – 12.2 m (25 - 40 ft) poles. These luminaires should be fully shielded or use IESNA full cutoff optics to eliminate glare. They should have a neutral aesthetic quality so that the luminaire “disappears” into its surroundings.

5-2.6.3 Sports Lighting Luminaires are shielded floodlights incorporating internal and external shields to control glare and light trespass.

5-2.6.4 Pedestrian poles light sidewalks, plazas, and other pedestrian areas. Mount on 3.7 m (12 ft) poles. These luminaires should have a low brightness but do not necessarily need to be fully shielded or full cutoff if the lamp is under 4200 lumens. Their aesthetic character should be appropriate for the surrounding buildings and landscape.

Figure 5-6. Pole mounted exterior luminaires.



5-2.6.5 Exterior Luminaire Classification. The National Electrical Manufacturers Association (NEMA) classifies exterior luminaires by intensity distribution. Tables 5-1 and 5-2 describe the distribution and cutoff classification. One classification refers to the illuminance pattern produced on the ground or horizontal surface (Table 5-1) and the other refers to the vertical candela distribution of light from an individual luminaire (Table 5-2). Each successive classification provides more vertical illuminance, but also introduces more glare and stray uplight. Full cutoff luminaires are typically used for roadway and area lighting to minimize glare, light trespass, and light pollution. Semi-cutoff and non-cutoff should be used only at low mounting heights and with low output lamps. Refer to paragraph 3-7.2 for additional requirements. Exterior sports lighting luminaires are classified according to the width of the beam spread and the projection distance to the field. Table 5-3 outlines these seven classifications.

Table 5-1. Exterior Luminaire Distribution Classification.³

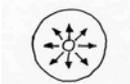
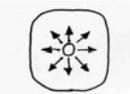
Type	Description	Plan View
Type I	Narrow, symmetric illuminance pattern.	
Type II	Slightly wider illuminance pattern than Type I.	
Type III	Wide illuminance pattern.	
Type IV	Widest illuminance pattern.	
Type V	Symmetrical circular illuminance pattern.	
Type VS	Symmetrical, nearly square illuminance pattern.	

Table 5-2. Exterior Luminaire Cutoff Classification.⁴

TYPE	DESCRIPTION	APPLICATIONS
Full Cutoff	A luminaire light distribution where zero candela intensity occurs at an angle of 90° above nadir and at all greater angles from nadir. Additionally, the candela per 1000 lumens does not numerically exceed 100 (10%) at a vertical angle of 80° above nadir. This applies to all lateral angles around the luminaire.	Use for roadway, parking, and other vehicular lighting applications. Minimizes glare and light pollution and light trespass.
Cutoff	A luminaire light distribution where the candela per 1000 lamp lumens does not numerically exceed 25 (2.5%) at an angle of 90° above nadir, and 100 (10%) at a vertical angle of 80° above nadir. This applies to all lateral angles around the luminaire.	Use in applications where pedestrians are present. Provides more vertical illuminance than Full Cutoff luminaires.
Semicutoff	A luminaire light distribution where the candela per 1000 lamp lumens does not numerically exceed 50 (5%) at an angle of 90° above nadir, and 200 (20%) at a vertical angle of 80° above nadir. This applies to all lateral angles around the luminaire.	Use in pedestrian areas. If using in residential areas, provide with houseside shields to minimize light trespass.
Noncutoff	A luminaire light distribution where there is no candela limitation in the zone above maximum candela.	Use for decorative applications only. Lamp brightness should be less than 4200 lumens.

³ "Luminaires", *Lighting Handbook Reference and Application*, Chapter 7, Ninth Edition (New York: The Illuminating Engineering Society of North America, 2000), p. 7-8.

⁴ "Luminaires", *Lighting Handbook Reference and Application*, Chapter 7, Ninth Edition (New York: The Illuminating Engineering Society of North America, 2000), p. 7-8.

Shielded		
----------	--	--

Table 5-3. NEMA Field Angle Classifications.⁵

Beam Type	Beam Spread Degree Range	Projection Distance
1	10 to 18	240 ft and greater
2	18 to 29	200 to 240 ft
3	29 to 46	175 to 200 ft
4	46 to 70	145 to 175 ft
5	70 to 100	105 to 145 ft
6	100 to 130	80 to 105 ft
7	130 and up	under 80 ft

5-2.7 Maintenance. Consider luminaire maintenance in the design process. By selecting long-life sources, the frequency of re-lamping can be reduced. Evaluate the ability to perform future maintenance in the installed location. For example, lighting in atriums, high maintenance bays, and other difficult to access lighting can be very hard to maintain. Determine if the selected design will require a lift or scaffolding just to replace lights. Lowering devices can be incorporated to bring a pendant-mounted luminaire to an accessible level. In such cases as atrium applications, consider wall-mounted luminaires that indirectly light an area. In cases of poor or limited access, evaluate lighting quality and luminaire life as part of the design.

5-2.7.1 Re-lamping:

5-2.7.1.1 Group relamping should be the principal method of periodically replacing lights in a given area. Base the group re-lamping frequency on ensuring intended lighting levels are maintained above minimum levels. Spot re-lamping is not recommended in this regard because lighting levels will tend to eventually fall below intended levels. The group re-lamping interval should consider the lamp mortality curve (provided by the manufacturer for each type of lamp) so that spot re-lamping does not become an excessive maintenance burden.

5-2.7.1.2 Spot re-lamping should be performed as necessary for appearance and safety.

5-2.7.1.3 Accessibility. Facility users are usually responsible for lamp replacements at and below 3 m (10 ft). Evaluate the lighting system design to confirm that users will be able to periodically replace the installed lamps.

5-3 **LAMPS.**

⁵ "Sports and Recreational Area Lighting", *Lighting Handbook Reference and Application*, Chapter 20, Ninth Edition (New York: The Illuminating Engineering Society of North America, 2000), p. 20-14.

5-3.1 Lamp Comparisons. Table 5-4 compares lamp types based on the following characteristics: efficacy (lumens of light per watt of energy), lamp life (the expected time of operation until 50% of the lamps are out), color temperature (the color of light emitted from the lamp), color rendering (how the light from the lamp shows other colors), start (time until the lamp is at full brightness), lumen maintenance (how the light output decreases over the lamp life), effects of ambient temperature on the lamp, and cost. This comparison illustrates that there is no “best” lamp. Choose lamps based on the criteria that are most appropriate to the project. Efficacy may be the guiding criteria to save the most energy; color rendering may be the most important issue in an area where colors will be viewed; or lamp life will be critical in hard to maintain areas.

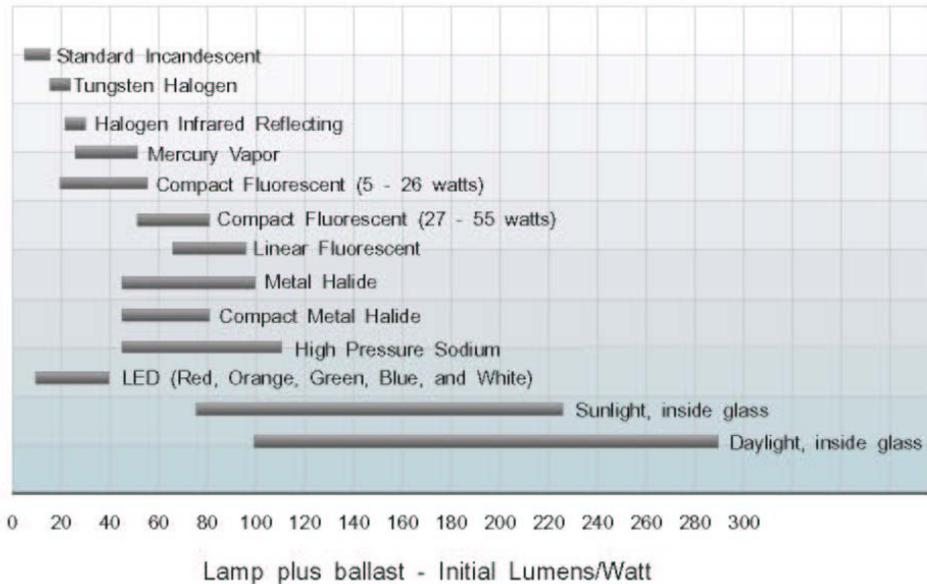
Table 5-4. Comparison of lamps.

	Efficacy (lumens / watt)	Lamp Life (hours)	Color Temp. (Kelvin)	Color Rendering Index	Start Time	Lumen Maintenance (%)	Dimming Capabilities	Effects of Temperature	Initial Cost
Compact Fluorescent	60 - 75	10,000	2700 - 4100	82	0	83 - 87	with dimming ballast	longer start and warm-up time in low temperatures	Med
Linear Fluorescent T8	80 - 95	20,000	2700 - 4100	75 - 85	0	83 - 87	with dimming ballast	longer start and warm-up time in low temperatures	Low
Linear Fluorescent T5HO	80 - 95	20,000	2700 - 4100	75 - 85	0	90 - 95	with dimming ballast	full output only at 35 degrees C (95 degrees F). Lower temperatures increase start time and light output	Med
Induction	60 - 75	100,000	3000 - 4000	80+	0	80	will soon be developed	low temperatures decrease light output	Very High
Metal Halide	80 - 90	10,000 - 20,000	3000 - 4200	65 - 90	5-10 min	80 - 85	yes, but expensive	none	High
High Pressure Sodium	90 - 105	24,000+	1900 - 2100	21 - 85	<5 min	88 - 92	none	none	High
Low Pressure Sodium	100 - 160	16,000	1800	poor	7-15 min	100	none	none	Med
Mercury Vapor	35 - 55	24,000	4000 - 5900	20 - 45	<10 min	60 - 65	none	none	Med
LED	varies by color	varies by color (up to 100,000)	varies by color	varies by color	0		with variable power supply	high and low ambient temperatures may adversely affect lumen depreciation and life	High
Tungsten Halogen	18 - 22	2000 - 4000	2800 - 3100	100	0	93 - 97	dimnable	none	Low
Incandescent	15 - 18	1000 - 3000	2700 - 3000	100	0	83 - 87	dimnable	none	Low

5-3.2 Lamp Efficacy. Lamp Efficacy is the number of lumens produced by a lamp per watt of electrical input. This quantity allows for a comparison between lamps and lamp wattages. Linear and compact fluorescent lamps have a high efficacy, which is several times higher than incandescent lamps (general service light bulbs). Choose the highest efficacy lamp that still meets the visual requirements for the application. Also, consider “effective lumens” (see paragraph 2-5.2.5) for exterior lighting applications.

Figure 5-7. Efficacy Comparison of Light Sources for General Lighting.

Ballast watts included for discharge lamps systems. Sunlight and daylight ranges calculated inside of single pane clear glass and high performance glass.⁶



5-3.3 Compact Fluorescent Lamps. Compact fluorescent lamps (CFL) replace the standard incandescent lamp. Because the CFL comes in a variety of wattages and sizes, and gives off a “glow” of light, it is ideal for wall sconces, decorative pendants, recessed wall washers, table lamps, torchieres, step lights, and exterior pedestrian lighting.

5-3.3.1 Select luminaires that are designed for the CFL complete with ballast, as opposed to luminaires that are designed for the standard incandescent but will accept a “screw in” type CFL replacement. Only use “screw in” replacements for a lighting retrofit when the cost of replacing the equipment is prohibitive.

5-3.3.2 Low wattage CFL lamps (less than 13 watts) generally have a lower efficiency and shorter lamp life than the CFL lamps of greater wattage. Also, use high wattage CFLs (42 watt and above) in luminaires where the lamp brightness is hidden or shielded.

⁶ New Buildings Institute, Inc. “Light Sources and Ballast Systems”, *Advanced Lighting Guidelines*, Chapter 6. 2001 Edition, 6-3. Neither the sponsors, authors, editors, advisors, publisher, or the New Buildings Institute, Inc. nor any of its employees make any warranty, express or implied, or assumes any legal liability or responsibility for the accuracy, completeness or usefulness of any data, information, method, product or process disclosed in this document, or represents that its use will not infringe any privately-owned rights, including but not limited to, patents, trademarks or copyrights. © 2001 by New Buildings Institute, Inc. All rights reserved.

5-3.3.3 In decorative wall sconces, pendants, table lamps, and torchiers, use 3000K CFL. Use either 3000K or 3500K CFL for wall washers, exterior pedestrian and landscape lighting. In other cases, match the color temperature of all different kinds of lamps in an area.

5-3.3.4 Requirements for compact fluorescent lamps:

- Do not use compact fluorescent lamps less than 13 watts.
- Use electronic or electronic dimming ballasts for all CFL.
- Do not mix compact fluorescent lamp color temperatures within a single building to minimize maintenance and the chance of visual confusion.
- U-Bent fluorescent lamps are not economically feasible and should not be used. (An economic analysis must be completed if there is another compelling design reason for using them.)

5-3.3.5 Considerations for compact fluorescent lamps:

- Use 3000K and 80 CRI as the default color temperature and color rendering index for residential, hospitality, food service, childcare, and healthcare projects.
- Use 3500K and 80 CRI as the default color temperature and color rendering index for commercial, office, and educational projects.

5-3.4 Linear Fluorescent Lamps. Linear fluorescent lamps are recommended for the majority of ambient area lighting, including high spaces. Linear fluorescents come in a variety of wattages and sizes, yet the most common and energy efficient lamps are the T8 and T5HO. These lamps are ideal for linear pendants, linear recess wall washers, recess wall slots, cove lights, stack or aisle lights, industrial and recreational lighting.

5-3.4.1 The advantages of linear fluorescents include energy efficiency, high color rendering, instant on/off switching, dimming capability, long life, and cost effectiveness.

5-3.4.2 Depending on the application, the T5HO (high output) can provide a more efficient alternative to the T8. Because this lamp produces a high level of light from a small lamp envelope, care must be given to shield the lamp from direct view unless used in a high ceiling application. In those cases, the luminaire reflector should be white and have an indirect component to balance out the lamp brightness.

5-3.4.3 High performance T8 lamps, sometimes referred to as "Super T8s," have the advantages of better color rendition and additional light output. By using optimized ballasts with these high performance lamps, the lamps gain a significant life advantage as well. This system for (1) 1.2 m (4 ft) T8 lamp produces 3100 initial lumens, uses 25 watts, provides 85 CRI, and has an average life of 30,000 hours. It is important to keep

in mind that all of these additional advantages are only achieved when the optimized ballast is paired with the high performance lamp. These ballasts are not available as dimming, only as instant start. A premium lamp can be used on a dimming ballast, but it will not have the lamp life benefit. On a dimming, or any non-optimized, ballast, the lamp will have an average of 20,000 to 24,000 hours. See the section on ballasts for additional information. Refer to the controls section for compatible devices with various ballast types.

5-3.4.4 Requirements for linear fluorescent lamps:

- Use electronic or electronic dimming ballasts for all linear fluorescents.
- Do not mix linear fluorescent lamp color temperatures within a single building to minimize maintenance and the chance of visual confusion.
- T12 lamps are prohibited. (The Energy Policy Act of 1992 ended production of many of these lamps.)

5-3.4.5 Considerations for linear fluorescent lamps:

- Use 3500K and 75+ CRI as the default color temperature and color rendering index.
- Use 3000K in housing and hospitality applications. Use 3500K in all other applications except for maintenance facilities where 4000K may be used.
- Consider T8, T5HO, and High Performance T8 lamps based on the application, initial cost, and potential energy savings.

5-3.5 Induction Lamps. Induction lamps are essentially fluorescent lamps without electrodes. Therefore, they have very high efficiencies and extremely long lives (70,000-100,000 hours). Induction lamps have many of the fluorescent lamp advantages such as superior color rendering, instant on/off switching, and long life.

5-3.5.1 Despite the high initial cost, these lamps offer significant cost benefits regarding low energy and maintenance costs. Because a typical relamping schedule may call for changing metal halide lamps after only 15,000 hours, while induction lamps can be changed after 60,000 hours, the savings in lamp replacements and labor costs quickly pays for the higher installation cost. In some cases, the payback period may be as short as 5-7 years. Most importantly, the induction lamp is extremely reliable. When compared against higher wattage HPS lamps, the energy savings of the induction lamp reduces the payback period even more.

5-3.5.2 The ideal application for induction lamps is in areas where metal halide or high-pressure sodium lamps may be used, even though the induction lamp is larger. Long life and instant on/off induction lamp characteristics make it very reliable and easy to control with motion sensors.

5-3.5.3 Considerations for induction lamps:

- Consider induction lamps for exterior area lighting, especially in “instant-on” applications.
- Consider induction lamps in low bay luminaires.
- Specify 3000 K lamps for exterior applications.

5-3.6 Metal Halide and Mercury Vapor Lamps. Metal Halide lamps provide a small point source of white light. Metal halide lamp efficacies and lamp life are increasing with pulse start technology. The disadvantages of the metal halide lamp are lumen depreciation and a long start up time. Additionally, these lamps also have a re-strike time. When a lamp is warm and then turned off, it must cool sufficiently before it can be re-ignited. This time delay is the re-strike time of the lamp. Even with these disadvantages, metal halide is a great source of white light, especially for exterior nighttime lighting, where it enhances peripheral vision.

5-3.6.1 Do not use mercury vapor lamps because of their poor color rendering properties and poor energy efficacy.

5-3.6.2 The ideal applications for metal halide lamps include exterior parking lots, roadway lighting, area lighting, indirect atrium lighting, and accent lighting.

5-3.6.3 Requirements for metal halide and mercury vapor lamps:

- Do not use mercury vapor lamps.
- Use electronic ballasts for metal halide lamps 150 watts and below. These ballasts are more reliable and use less energy than magnetic ballasts. Currently they are only available for 150 watt lamps and lower. (If higher wattages become available from (3) manufacturers, they should be considered.)

5-3.6.4 Considerations for metal halide lamps:

- Consider metal halide lamps for exterior lighting in areas of pedestrian traffic and where light color and color rendering are important.
- Consider pulse start metal halides if possible. These lamps have improved lumen maintenance and longer lamp life. (Available for vertical lamps only.)
- Consider metal halide PAR lamps (50 watts or lower) for accent lighting, including flags.
- Use metal halide lamps (100 watts and higher) in fully shielded or IESNA full cut-off luminaires.

- Specify 3000K coated metal halide lamps for exterior applications.

5-3.7 Light Emitting Diodes (LEDs). Lighting Emitting Diodes (LED) will become increasingly important for all types of lighting. LEDs produce a directional narrow beam of light making it ideal for exit signs, traffic signals, and other directional light source applications. LED efficacies are increasing constantly, soon making LED luminaires an effective means for all types of lighting applications. Because LEDs are monochromatic, white light is difficult to produce unless different colors are combined. LEDs have extremely long lives (100,000 hours) and consume very little energy. LEDs are also dimmable.

5-3.7.1 The ideal applications for LEDs are in areas where high brightness is very important such as exit signs, general signage, step lighting, and directional accent lights.

5-3.7.2 Considerations for LEDs:

- Use LED sources in all exit signs, other lighted information signs and traffic signals.
- Consider LED sources for step lighting, nightlights, low brightness wall sconces, and other low level lighting applications.

5-3.8 High-Pressure Sodium / Low-Pressure Sodium Lamps. High-Pressure Sodium lamps are typically used for exterior applications. Although high-pressure sodium lamps have long lives (20,000 hours) and appear to be efficacious, there are several problems with them. The most important is the lack of short wavelength light such as blue and green light. As a result, one's peripheral vision under nighttime exterior lighting conditions, does not respond well to the color of light of the high-pressure sodium lamps. White light can be two to twenty times more effective for peripheral vision detection than high-pressure sodium. High-pressure sodium lamps are not advised for interior applications. Because short wavelength light controls the pupil, high-pressure sodium lamps cause objects to be "out of focus". In addition, HPS lamps render color poorly. Refer to Chapter 2, "Lighting Design Considerations" for lumen effectiveness multipliers. High-pressure sodium lamps can be used where existing conditions and continuity of source types make it necessary.

5-3.8.1 Low-pressure sodium lamps provide poor nighttime visual acuity and poor color rendering.

5-3.8.2 Requirements for high and low pressure sodium lamps:

- Do not use low-pressure sodium lamps except for unique applications such as in sea turtle nesting areas.

5-3.8.3 Considerations for high-pressure sodium lamps:

- Consider white light sources such as induction, metal halide and

fluorescent lamps rather than high-pressure sodium lamps where peripheral detection is important such as pedestrian walkways, parking areas, and other outdoor areas where pedestrians are present. Refer to paragraph 2-5.2 for additional information on the effectiveness of white light.

- Consider high-pressure sodium to maintain continuity with existing conditions and adjacent projects.

5-3.9 Incandescent and Tungsten Halogen Lamps. Incandescent and tungsten halogen lamps use the most energy for the amount of light output, and also require high maintenance. The use of standard incandescent is not allowed for new installations. Avoid tungsten halogen lamps unless deemed necessary for the specialized application, such as accent lighting a key feature or artwork. In these applications, consider using a low wattage PAR metal halide as an alternative.

5-3.9.1 Requirements for incandescent and tungsten halogen lamps:

- Do not use standard incandescent lamps. Except for specialty applications such as photograph development areas.

5-3.9.2 Considerations for incandescent and tungsten halogen lamps:

- Limit the use of tungsten halogen lamps. When low-level accent lighting is necessary for a special application, use tungsten halogen lamps with a minimum efficacy of 20 lumens per watt.
- Xenon lamps can be used as an alternative to standard incandescent lamps especially in landscape lighting applications. These lamps have a significantly longer life.
- When tungsten halogen is absolutely necessary, the lighting must be on an easily accessible dimmer to extend lamp life.
- Use alternative sources such as compact fluorescent in place of standard incandescent lighting.

5-4 **BALLASTS AND POWER SUPPLIES.**

5-4.1 Electronic Ballasts. The use of electronic ballasts as opposed to older technology core and coil ballasts reduces the energy requirements of fluorescent and HID sources. The nominal wattage of a fluorescent or HID lamp is typically lower than the wattage that the lamp/ballast system actually draws, or the “input watts”. For example, a thirty-two watt compact fluorescent lamp draws thirty-five watts through the ballast when in operation. This input wattage is minimized with electronic ballasts. They also have the benefits of less noise, reduced flicker, smaller size, less weight, and lower starting temperature.

5-4.2 Linear Fluorescent. Select ballasts for linear fluorescent lamps that operate at a high frequency (greater than 30 KHz) and low total harmonic distortion. Provide ballasts with a high ballast factor (greater than 0.95). Provide programmed start ballasts for T5 and T5HO lamps that include end of life protection.

5-4.2.1 Instant Start fluorescent ballasts have the advantage of lower input wattages. However, if the lamps are switched frequently, the instant start will decrease the life of the lamp. Therefore, the energy savings is only a benefit in applications where the lamps will be turned on and left on for a long period of time. These must not be used in applications where individual occupants have control over the lighting or with automatic controls such as daylight and occupancy sensors.

5-4.2.2 Rapid Start fluorescent ballasts start the lamp in a softer manner that takes a few seconds to turn on, but does not decrease the life of the lamp with frequent switching. They do not have the same energy benefit as instant start ballasts.

5-4.2.3 Programmed Start fluorescent ballasts delay the heating of the lamp when it is started. This ballast increases the lamp life and also operates the lamp at a slightly lower input wattage than rapid start ballasts. However, the input wattage is slightly higher than instant start ballasts. Some manufacturers are discontinuing the rapid start ballast and replacing them with programmed start. Use Programmed Start fluorescent ballasts in areas controlled with occupancy sensors.

5-4.3 Compact Fluorescent. Select ballasts for compact fluorescent lamps that operate with a high power factor (greater than 90%). Provide programmed start ballasts for compact fluorescent lamps that include end of life protection.

5-4.4 High Intensity Discharge. Provide HID ballasts with a high power factor (minimum of 90%). Provide electronic metal halide ballasts for 150 watt and lower. These ballasts are more reliable and use less energy than magnetic ballasts. Currently they are only available for 150 watt lamps and lower. If higher wattages become available from (3) manufacturers, they should be considered.

5-4.5 Induction. Induction lamps require the support of both a high frequency generator and a power coupler. The overall operating system should include a five-year minimum warranty.

5-4.6 Light Emitting Diodes (LED). LED power supplies convert an input voltage to low voltage DC output. One power supply module may operate multiple LED luminaires. Dimmable power supplies are available.

5-4.7 Noise. Electromagnetic (core and coil) ballasts operate with a "hum" while electronic ballasts produce little or no noise. Provide ballasts with a Class A noise rating.

5-4.8 Flicker. HID lamp sources will flicker due to the changes in line voltage. This

flicker effect may be noticeable in certain applications and can be effectively eliminated with the use of high frequency electronic ballasts⁷. If electronic ballasts are not used, the phases can be rotated to minimize flicker.

5-4.9 Interference. Electronic ballasts have the potential to cause Electromagnetic Interference (EMI) and Radio Frequency Interference (RFI) when operated near other high frequency electronic equipment. This can be a significant issue when installed near electronic medical equipment. To prevent such interference, specify magnetic ballasts in those areas. Another more energy efficient option that will also avoid such interference is low frequency electronic ballasts. Available from some manufacturers, these ballasts operate at low frequencies and will not interfere with sensitive equipment. These ballasts should be specified with <20% Total Harmonic Distortion (THD).

5-4.10 Effects of Temperature. Ambient air temperature affects the performance and output of fluorescent lamps. In exterior, low temperature applications (less than ten degrees C) provide ballasts capable of low temperature lamp starts. Light output will be reduced until lamp warms up to operating temperature. Mercury amalgams added to fluorescent lamps improve the lamp performance and provide for operation over a wide temperature range. These lamps typically take slightly longer to reach normal operating temperature and full light output.

5-4.11 Life. The operating temperature of ballasts directly affects the life. The luminaire housing or ballast enclosure should provide for adequate dissipation of heat. When ballasts operate at excessive temperatures, the insulation degrades, resulting in a shortened ballast life.

5-5 LIGHTING CONTROLS.

5-5.1 Control system design. When controls are used wisely, the benefits of occupant satisfaction and energy savings can lead to long lasting economic benefits. When designing controls, evaluate areas as to whether they are task or non-task dominant areas. Task dominant area examples include offices, conference rooms, classrooms and maintenance areas. Non-task dominant area examples include transition areas such as corridors, lobbies, atriums or support areas such as cafeterias, restrooms, and storage areas. Even the best-designed control strategy does not work if people feel “controlled” and over-ride the controls.⁸

5-5.1.1 Task dominant areas. Daylight dimming provides the highest level of satisfaction since the lighting smoothly responds to daylight availability versus an abrupt on/off. Ideally, manual dimming with an upper daylight limit provides the greatest flexibility and highest acceptance since people have control over their areas. In addition, occupancy sensors allow the lighting to turn off if no one is in the area.

⁷ “Light Sources”, *Lighting Handbook Reference and Application*, Chapter 6, Ninth Edition (New York: The Illuminating Engineering Society of North America, 2000), p. 6-50.

⁸ “Lighting Values”, *Light Right Consortium*, 2001 - 2003 <<http://www.lightright.org>>

5-5.1.2 Non-task-dominant areas. Automatic daylight on/off is more acceptable in these areas, yet dimming is still preferred. Occupancy sensors in these public areas will save the most energy, though lights can be turned off with an energy management system. If occupancy devices allow adequate time, especially in transition areas, then the lighting is not disrupted during normal hours of operation.

5-5.1.3 Passive infrared sensors detect the difference in heat between a human and the surroundings. Because of this, the sensor must be able to “see” the entire space and any obstruction such as partitions, shelves, or cabinets will block detection. Changes in ambient temperature will also reduce the effectiveness of infrared sensors.

5-5.1.4 Ultrasonic technology relies on high frequency sound waves to detect movement in the space. This movement could be a person moving, or air movement created by a person’s activity. This type of sensor is therefore appropriate for spaces that have partitions such as restrooms or open office areas. Such sensors need to be located so that they do not sense the “false-occupancy” of an air vent or a passer-by in an adjacent space. Room finishes such as carpeting may absorb the ultrasonic waves and reduce coverage.

5-5.2 The light source also needs to be considered in designing a control system. Some sources are more suitable for dimming or switching than others. Dimming and switching may also affect the life of the lamp. In other cases, undesirable color shift may occur when a source is dimmed. Table 5-7 outlines some of the issues that need to be considered in matching control strategies with lamps. In all cases, lighting controls must be commissioned to optimal operation and user satisfaction.

Table 5-5. Recommended Control Devices for Different Building Applications.⁹

Strategy	Scheduling					Daylighting and Tuning				
	Wallbox Occ. Sensor	Ceiling/Wall Occ. Sensor	Personal Occ. Sensor	Timer	Time Clock Device	Multilevel Switching	Manual Wallbox Dimmer	Wireless Remote Dimmer	Photoswitch	Photosensor
Assembly & Light Manufacturing			○		●	○			○	●
Auditoriums		●				○	●	●		
Classrooms		●				●	●	●	○	●
Concourses, Lobbies, Malls					●	●			●	●
Conference Rooms	○	●		○		○	●	●		●
Exterior Lighting		○			●	○			●	
File/Storage Rooms		●		●						
Grocery/Supermarket		●		○	●	●			○	○
Gymnasiums		●				○			○	
Hallways		●			●				●	○
Laboratories		●	○			○	●			●
Library Reading Areas		●			○	○				●
Library Stacks		●		●	○	○				
Locker Rooms		●			○	○				
Lunch/Break Rooms	○	●		○		○			○	
Medical Suite/Exam Rooms	○	●				●	●			
Museums		○				●	●		○	●
Open Offices		○	●		●	●	●			●
Private Offices	○	●	●		●	●	●	●		●
Restaurants					○	●	●	○		○
Restrooms	○	●		○		○				
Retail Sales Area					○		○		○	○
Warehouse		●		○	●	●			○	○

● = good application ○ = limited application

⁹ New Buildings Institute, Inc. "Lighting Controls", *Advanced Lighting Guidelines*, Chapter 8. 2001 Edition, 8-5, 8-12. Neither the sponsors, authors, editors, advisors, publisher, or the New Buildings Institute, Inc. nor any of its employees make any warranty, express or implied, or assumes any legal liability or responsibility for the accuracy, completeness or usefulness of any data, information, method, product or process disclosed in this document, or represents that its use will not infringe any privately-owned rights, including but not limited to, patents, trademarks or copyrights. © 2001 by New Buildings Institute, Inc. All rights reserved.

Table 5-6. Lighting Control Energy Savings Examples by Application & Control Type⁸

Space Type	Controls Type	Maximum Expected Yearly Energy Savings
Private Office	Occupancy Sensor	45%
	Sidelighting w/ photosensor	35%
	Manual dimming or multilevel switching	30%
Open Office	Sidelighting w/ photosensor	40%
	Occupancy Sensor	35%
Classroom	Multilevel switching	15%
	Sidelighting w/ photosensor	40%
	Occupancy sensor	25%
Grocery Store	Adaptive compensation	15%
	Toplighting w/ photosensor	40%
Big Box Retail	Toplighting w/ photosensor	60%
	Bilevel switching	10%

Table 5-7. Lighting Control Considerations.

Light Source	Switching Considerations	Dimming Considerations
Compact Fluorescent	With frequent switching (including occupancy controls) use programmed or rapid start ballasts. Provide ballasts with end-of-life protection.	Requires electronic dimming ballasts and compatible controls. Dimming cannot decrease light below a minimum point without flicker. Some color shift occurs when dimmed. Systems can dim lights smoothly and effectively to 5%-10% of initial lamp output. 1% dimming is available but significantly more expensive.
Linear Fluorescent	Inexpensive. With frequent switching (including occupancy controls) use programmed or rapid start ballasts. Do not use instant start ballasts.	Requires electronic dimming ballasts and compatible controls. Dimming cannot decrease light below a minimum point without flicker. Some color shift when dimmed. Systems can dim lights smoothly and effectively to 5%-10% of initial lamp output. 1% dimming is available but significantly more expensive.
Induction	No operating issues.	Dimming is not available.
HID Sources	Inexpensive. Due to warm up and restart times, access to switches should be limited. Not suitable for occupancy sensors or frequent switching.	Requires special ballasts and control systems. Dimming cannot decrease light below a minimum point. Lamp efficacy of source diminishes with dimming. Significant color shift and lamp life problems.
LED	No operating issues.	Requires a dimming power supply.
Tungsten Halogen and Incandescent	No operating issues.	Will extend lamp life. Dimming is full range and appealing. Some energy savings.

5-6 EMERGENCY AND EXIT LIGHTING.

5-6.1 Introduction. The purpose of emergency lighting is to ensure the continuation of illuminance along the path of egress from a building and provide adequate light for the orderly cessation of activities in the building. The purpose of exit lights is to identify the path of egress. Both types of lighting must be powered from both a normal power source and an emergency source, with automatic switching from one to the other.

5-6.1.1 In some specific situations, emergency lighting might be required for specific spaces or work areas that are not on the path of egress. There are often areas where work of a critical nature must continue regardless of loss of normal power, such as a computer mainframe room. In health care facilities, including hospitals, skilled nursing homes, and residential custodial care facilities, lighting for the path of egress (including exit signs) and elevator cabs is considered “life safety” lighting and must be connected to the life safety branch of the facility’s emergency power system. Task illumination at anesthetizing locations, patient care areas, laboratories, intensive care units, recovery rooms, and other locations as required by NFPA 70, Article 517 are considered “critical” lighting and must be powered from the critical power branch of the facility’s emergency power system. In applications where the loss of light, even momentary, would endanger personnel or risk other loss or damage, provide lighting systems to maintain constant illumination through the use of an uninterruptible power supply of sufficient capacity to permit an orderly cessation of activity. This lighting is in addition to path-of-egress lighting.

Figure 5-8. Typical exit sign.



5-6.2 Requirements for emergency lighting:

- Although an elevator is not considered a component in the required means of egress, all elevators must provide lighting in accordance with ANSI A17.1 or ANSI A17.3 as applicable.
- Where emergency lighting is required, arrange the system so that the failure of any individual lighting element, such as the burning out of a light bulb, cannot leave any space in total darkness.

5-6.3 Requirements for exit marking:

- Lettering on all exit signs for an installation must be one uniform color.

Each base must establish either red or green as the standard lettering color. Installations in or near jurisdictions with established exit sign lettering colors should adopt similar red or green standards. Do not replace existing exit signs meeting NFPA 101 requirements simply to standardize sign colors. When signs must be replaced for other reasons, use the installation color.

- Installations overseas can use different colors, pictorials, or bilingual lettering as necessary to comply with local national standards. All exit signs must be immediately obvious as an exit marking to a recently transferred or visiting U. S. citizen. Additional markings are permitted to comply with host nation standards.

5-6.3.1 Acceptable Exit Signs:

- Use LED exit signs with illuminated letters displayed on an opaque background unless directed otherwise for particular applications.

5-6.3.2 Prohibited Exit Signs:

- Radioluminous. All existing signs were required to be replaced by 1 June 1996.
- Incandescent. Do not use signs lit by incandescent lamps in new construction. Existing incandescent signs can remain in service. When replacement is dictated by maintenance or construction requirements, replace the signs with LED exit signs, or refit them with LED conversion units.

5-6.4 Testing of Emergency Lighting Equipment. Because of the periodic testing requirements, accessibility of equipment is an important design consideration. Ensure that emergency lighting equipment is installed in conspicuous and accessible locations to facilitate the periodic testing requirements.

5-7 **INSTALLATION REQUIREMENTS.** The National Electrical Contractors Association (NECA) and the IESNA have produced extensive documentation on recommended practices for lighting installation. These documents include: NECA/IESNA 500 and NECA/IESNA 502. Installation, operation, and maintenance issues are also detailed in ANSI C2-2002.

5-7.1 Wetness. Determine whether “dry”, “damp”, or “wet” conditions apply.

5-7.2 Environmental Conditions. Determine whether any special environmental conditions apply, such as a corrosive or explosive atmosphere, extremely cold or hot locations, marine/salt water atmosphere, clean room, food preparation area, or other unusual requirements

5-7.3 Structural Support. Determine the supporting means for the lighting systems,

including specific considerations for seismic reinforcement and other conditions.

5-7.4 Ceiling System. When lighting systems are intended to be recessed into or mounted onto ceilings, determine the ceiling system type and capacity for lighting, including plenum height and other factors. Determine whether the ceiling is fire rated. Consider insulation locations and IC ratings of fixtures for residential projects.

5-7.5 Power System. Determine the available voltages, frequency, and capacity of power sources for lighting.

CHAPTER 6

INTERIOR APPLICATIONS

6-1 **INTRODUCTION.** This chapter identifies typical interior facility applications and explains the critical design issues for each as outlined in the Quality of the Visual Environment chapter of the *Lighting Handbook*. Each application details a conceptual lighting design for a sample space with a sketch and equipment recommendation. This sample represents one solution that addresses the design issues and meets the appropriate criteria. It is not the only solution and alternate schemes will result in acceptable designs.

6-2 **LIGHTING CALCULATIONS FOR INTERIOR SPACES.**

6-2.1 **Criteria.** Lighting for interior areas is measured with a variety of parameters. Maximum, minimum, and average illuminance values are often listed as target criteria. Uniformity criteria may be described with multiple terms including maximum to minimum and maximum to average. The most appropriate criteria vary with the type of application. The following lists this UFC's interpretation of the IESNA criteria and how it is used in the applications shown in this chapter:

- **Minimum illuminance:** This provides the low end of the range of acceptable light levels. This is typically used to define the light level required to perform a specific task.
- **Maximum illuminance:** This provides the high end of the range of acceptable light levels. This is typically used to prevent overlighting of an area.
- **Average illuminance:** This criterion is typically used to give an approximate light level. Unless noted otherwise, the values given in this chapter designate an average illuminance value.
- **Maximum to minimum uniformity:** This is typically used to prevent excessive contrast. This is most important in work areas where individuals will spend large amounts of time such as office spaces.

6-2.2 **Lumen Method.** The lumen method is a calculation procedure that can be performed by hand or by simple, spreadsheet formulas. It determines the average illuminance in a space, and is reliable only for spaces with a regular and uniform "grid" of luminaires in which general lighting, providing task light levels everywhere, is appropriate. The lumen method also can be used for determination of "ambient" illumination in rooms in which localized "task lights" are used strictly for task light. Refer to IESNA RP-23 or the *Lighting Handbook* for additional information.

6-2.3 **Point Calculations Using Flux Transfer Calculations.** Commercially available computer programs that assume Lambertian (matte or flat) room surfaces can perform

point calculations. These calculations indicate illuminance at specific points and are capable of exitance and luminance calculations as well. Some programs can incorporate objects in space to assess the lighting in a non-empty room. Many programs generate perspective views of illuminated rooms, although due to the lack of specular reflectivity these rooms do not have a photo-realistic appearance.

6-2.4 Point Calculations Using Radiosity Calculations. Commercially available computer programs that allow for diffuse and specular room surfaces can perform point calculations. These calculations indicate illuminance at specific points and are capable of exitance and luminance calculations as well. Some programs can incorporate objects in space to assess the lighting in a non-empty room. Many programs generate perspective views of illuminated rooms, which in some cases can be quite realistic.

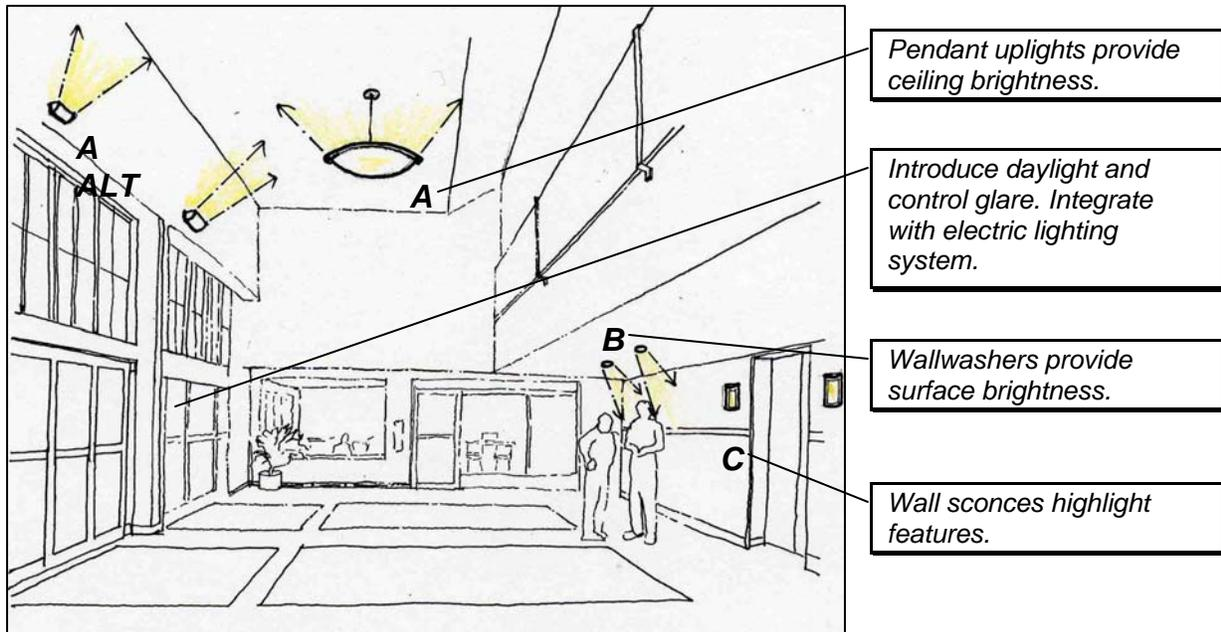
6-2.5 Daylighting Calculations. Refer to IESNA RP-21 or the *Lighting Handbook*. Daylight availability can be estimated using these methods. Many point calculation programs can also model daylight contributions. In addition, some commercially available computer programs such as *SkyCalc*¹ will determine the contribution of daylight at a specific time and date and under specific weather conditions.

6-2.6 Task Lighting Calculations. Due to near-field photometric effects, the illuminance patterns created by task lights are presently not accurately calculable. Evaluate task lights on the basis of measured results or manufacturers' information.

6-2.7 Energy Calculations. Perform energy calculations in the manner and using the forms described in the ASHRAE 90.1 User's Manual. Use Tables 15-11 and 15-12 for the Federal values to be used in ASHRAE 90.1 calculations. These tables provide the federally required maximum allowable unit power density in terms of watts per square foot, which varies with the type of area and function. These tables have been provided here to avoid any inconsistencies in the use of the federally required values. Commercially available software programs, such as DOE II, Energy 10, and BLAST, simulate multiple building systems to provide a better understanding of energy benefits and trade-offs of various design strategies. For a complete list and description of these programs refer to the Whole Building Design Guide *Energy Analysis Tools* (www.wbdg.org).

¹ The Heschong Mahone Group, *Skylighting Guidelines*, 1998.

OFFICES



EQUIPMENT RECOMMENDATIONS:

	LUMINAIRE	LAMP	CONTROLS
A	<i>Pendant mounted decorative luminaire.</i>	<i>Compact fluorescent lamps, 3500K color temperature, 80 CRI + or metal halide</i>	<i>Daylight dimming or switching.</i>
A ALT	<i>Wall mounted uplight.</i>	<i>Compact fluorescent lamps, 3500K color temperature, 80 CRI + or metal halide</i>	<i>Daylight dimming or switching.</i>
B	<i>Recessed compact fluorescent wallwasher</i>	<i>Compact fluorescent lamp, 3500K color temperature, 80 CRI +</i>	<i>Daylight dimming or switching.</i>
C	<i>Wall mounted compact fluorescent sconce.</i>	<i>Compact fluorescent lamp, 3500K color temperature, 80 CRI +</i>	<i>Timeclock On / Off, coordinated with building schedule.</i>

CRITICAL DESIGN ISSUES:

- Daylighting Integration and Control: Many lobbies are designed with daylight as a primary feature of the space. By integrating lighting controls with the daylight design, electric lighting equipment can be turned off when not required.
- Appearance of Space and Luminaires: Because lobbies are often the first space visitors to the building see, the aesthetic appearance of the space and the luminaires is an important criterion. Luminaire layout should avoid “visual clutter” of the space.

- Luminance of Room Surfaces: Downlighting the volume of a space from a high ceiling consumes a lot of energy. Lighting the wall and ceiling surfaces can achieve increased brightness with less energy. Typically people spend a limited amount of time in such spaces and are not occupied with difficult visual tasks. Therefore, the luminances of the surfaces are far more important than the horizontal illuminance.
- Color Appearance (and Color Contrast): The color of accent walls, architectural features, and artwork needs to be rendered accurately. For this reason, tungsten halogen, fluorescent or ceramic metal halide lamps with a high color-rendering index (CRI) should be used to accent such features.
- Modeling of Faces or Objects: Ambient lighting for lobby spaces should include indirect lighting and come from multiple directions and angles. For example, if multiple systems such as sconces, pendants, and wallwashers all provide light from multiple directions, three-dimensional objects will appear three dimensional in form. However, if all of the lighting is aimed straight down at the floor, objects in the space will have harsh shadows and appear “flat”.
- Target Horizontal Illuminance ($\pm 10\%$): 100 lux (10 fc)

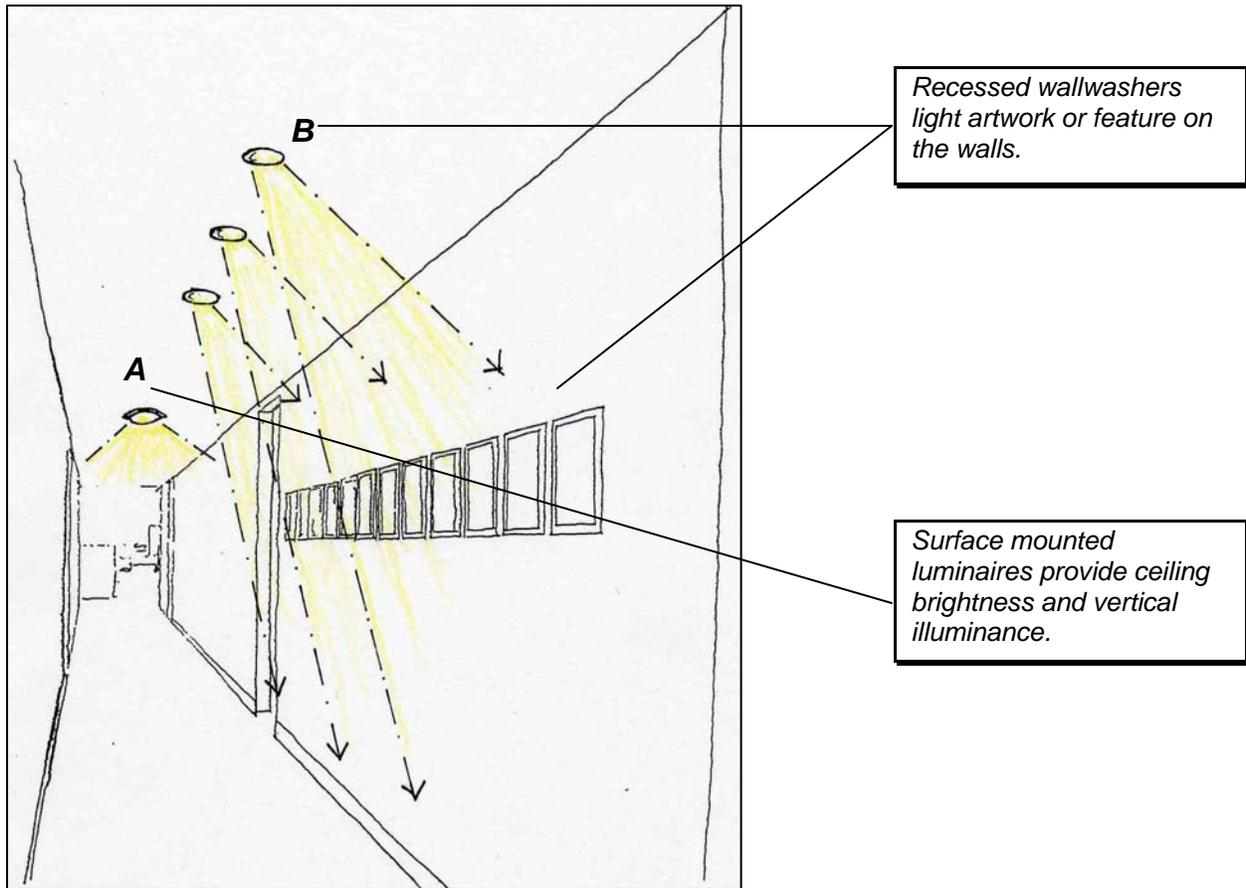
DISCUSSION:

As in most interior spaces, lobbies require the lighting of surfaces as opposed to volumes. In such high spaces, high wattage downlights are often recessed into the ceiling and aimed at the floor. After traveling through the entire volume of the space, very little light reaches the floor only to illuminate a low reflectance surface. Downlights can also create harsh shadows on people and objects.

A more effective and energy efficient lighting scheme illuminates high reflective surfaces as well as specific features in an ambient / accent approach. In the figure above, decorative pendants light the ceiling. This ambient system also can be easily integrated with the available daylight in the space. Wall washers illuminate walls and artwork and sconces identify the elevator doors, assisting in wayfinding for building visitors.

OFFICES

Corridors



Recessed wallwashers light artwork or feature on the walls.

Surface mounted luminaires provide ceiling brightness and vertical illuminance.

EQUIPMENT RECOMMENDATIONS:

	LUMINAIRE	LAMP	CONTROLS
A	<i>Surface mounted compact fluorescent luminaires.</i>	<i>Compact fluorescent lamp 3500K color temperature, 80+ CRI</i>	<i>Daylight switching if available. Consider occupancy sensors for low use corridors or after hours.</i>
B	<i>Recessed compact fluorescent downlight / wallwashers</i>	<i>Compact fluorescent lamp 3500K color temperature, 80+ CRI</i>	<i>Daylight switching if available. Consider occupancy sensors for low use corridors or after hours.</i>

CRITICAL DESIGN ISSUES:

- **Daylight Integration and Control:** If daylight can be introduced into corridors, the corridor's electric lighting can be turned off when there is adequate light. In infrequently used corridors, occupancy sensors can also be used to provide light only when needed.
- **Direct Glare:** Avoid direct glare even in transitional spaces such as corridors.

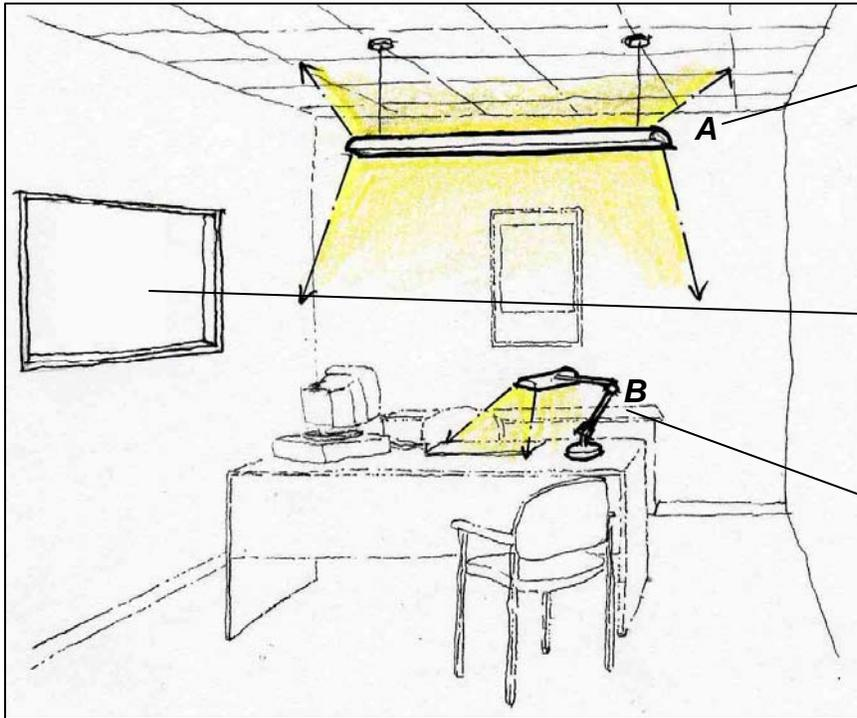
- Light Distribution on Surfaces: Lighting surfaces increases the perceived brightness of the space, makes the space feel larger, and can reduce the amount of energy required.
- Modeling of Faces or Objects: Light should come from multiple directions to adequately light individuals in the corridor. A system of downlights will cast harsh shadows on an occupant's face.
- Point(s) of Interest: Lighting photos, art, or other displayed features in a corridor can break the repetition of the lighting and add interest to the corridor. It also illuminates a surface that is prominent in the occupant's field of view.
- Target Horizontal Illuminance ($\pm 10\%$): 50 lux (5 fc)

DISCUSSION:

Although people spend little time in such transitional spaces, corridors can feel small and cramped with poor lighting and can represent a significant energy use. Lighting ceiling and wall surfaces increases the surface brightness and the overall perceived brightness of the space. This also makes the space feel larger and wider and can do so with the same or less energy than a downlighting only scheme. Surface mounted luminaires add vertical brightness on faces and also can help in indicating corridor intersections.

OFFICES

Individual Offices



Direct / indirect luminaires selected and located to prevent direct and reflected glare.

Introduce and control daylight. Integrate with electric lighting control.

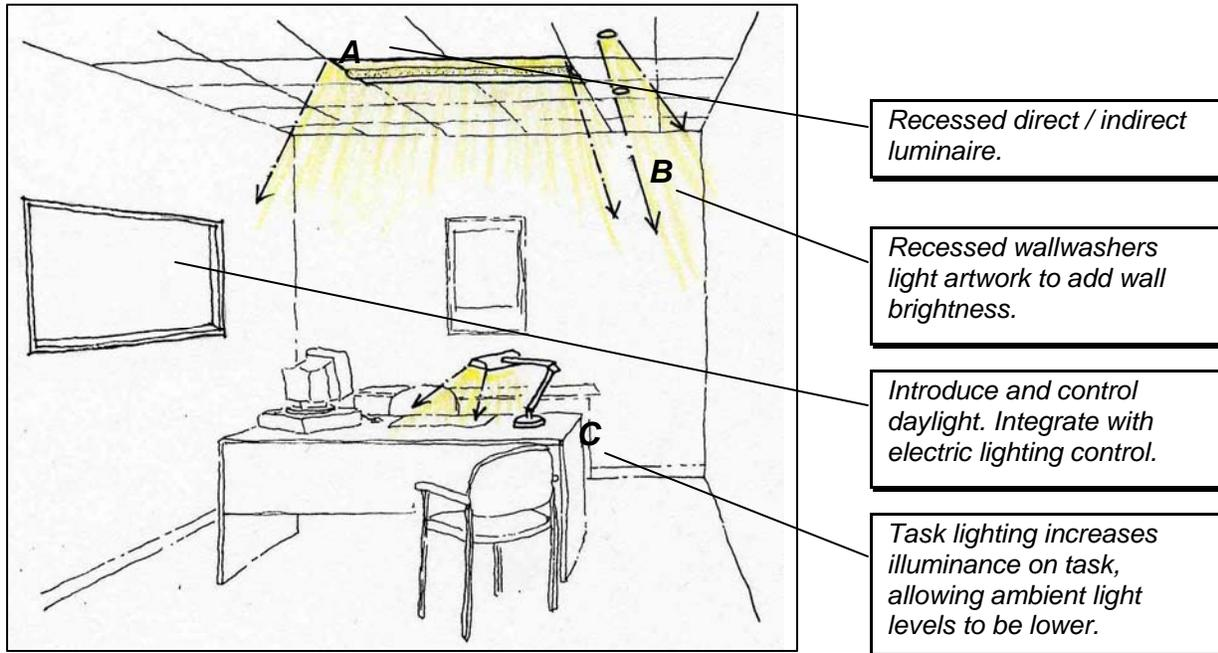
Task lighting increases illuminance on task, allowing ambient light levels to be lower.

EQUIPMENT RECOMMENDATIONS:

	LUMINAIRE	LAMP	CONTROLS
A	Pendant mounted linear fluorescent, indirect / direct luminaire, mounted 0.5 – 0.9m (18” – 36”) below ceiling	4’ linear fluorescent T8 lamps 3500K color temperature, 75 CRI +	Daylight dimming or switching or connected to occupancy sensor. Control ambient and accent lighting separately.
B	Task light	Compact or linear fluorescent lamp, 3500K color temperature, 80 CRI +	Manual on/off or connected to occupancy sensor.

OFFICES

Individual Offices (Alternate Scheme)



Recessed direct / indirect luminaire.

Recessed wallwashers light artwork to add wall brightness.

Introduce and control daylight. Integrate with electric lighting control.

Task lighting increases illuminance on task, allowing ambient light levels to be lower.

EQUIPMENT RECOMMENDATIONS:

	LUMINAIRE	LAMP	CONTROLS
A	<i>Recessed linear fluorescent direct/indirect luminaire.</i>	<i>4' linear fluorescent T8 lamps 3500K color temperature, 75 CRI +</i>	<i>Daylight dimming or switching or connected to occupancy sensor. Control ambient and accent lighting separately.</i>
B	<i>Recessed compact fluorescent downlight wallwasher.</i>	<i>Compact fluorescent lamp 3500K color temperature, 80 CRI +</i>	<i>Daylight dimming or switching. Control ambient and accent lighting separately.</i>
C	<i>Task light</i>	<i>Compact or linear fluorescent lamp, 3500K color temperature, 80 CRI +.</i>	<i>Manual on/off or connected to occupancy sensor.</i>

CRITICAL DESIGN ISSUES:

- Direct Glare: Lamps in the luminaire are shielded with louvers, perforations, or lenses to avoid a view of the lamps and the resultant direct glare.
- Luminances of Room Surfaces: Room surfaces need to be illuminated to control the contrast between the occupant's task and the surrounding surfaces in that person's field of view. This is especially important with computer use when a person views a bright screen in the foreground. If the background is too dark, the contrast will lead to eyestrain and fatigue.
- Uniformity: Luminance uniformity should not exceed 5:1 in immediate work surrounds, not including accent lighting.
- Reflected Glare: When viewing tasks with a glossy finish, bright luminaire components such as visible lamps or bright lenses reflect in the surface of the task. This situation can make reading tasks annoying and at times impossible.
- Source / Task eye geometry: Task areas and luminaire locations need to be identified to avoid shadows and direct and reflected glare.
- Target Horizontal Illuminance ($\pm 10\%$): 300 lux (30 fc) ambient, 500 lux (50 fc) on the task

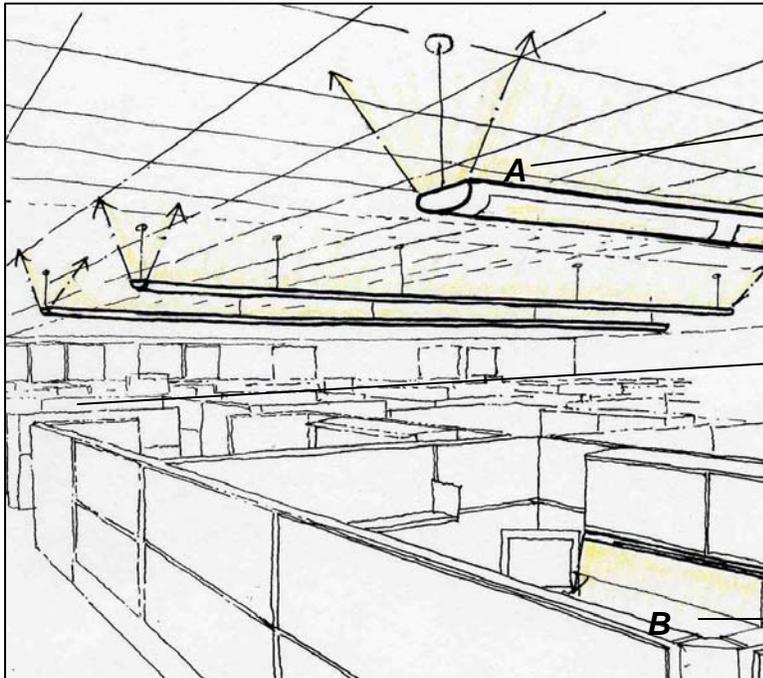
DISCUSSION:

A task/ambient approach to the lighting in an individual office results in separate control over an ambient system (typically a pendant mounted direct/indirect luminaire) and task lighting (a desk or undercabinet light). In larger offices or interior offices, additional wallwashing may be necessary to add wall surface brightness. By providing a high illuminance level on the task only and not the entire room, energy is saved in the ambient system, which does not have to produce as much light. This approach also provides a comfortable and flexible lighting environment.

Control devices could be as simple as manual on/off or dimming of the separate systems. Occupancy sensors (individual or incorporated into wall switches) save additional energy when someone is not in the office.

OFFICES

Open Offices



Pendant mounted direct/indirect luminaires selected and located to prevent direct and reflected glare.

Introduce daylight from north and south facades and control glare. Integrate daylight with electric lighting system where appropriate.

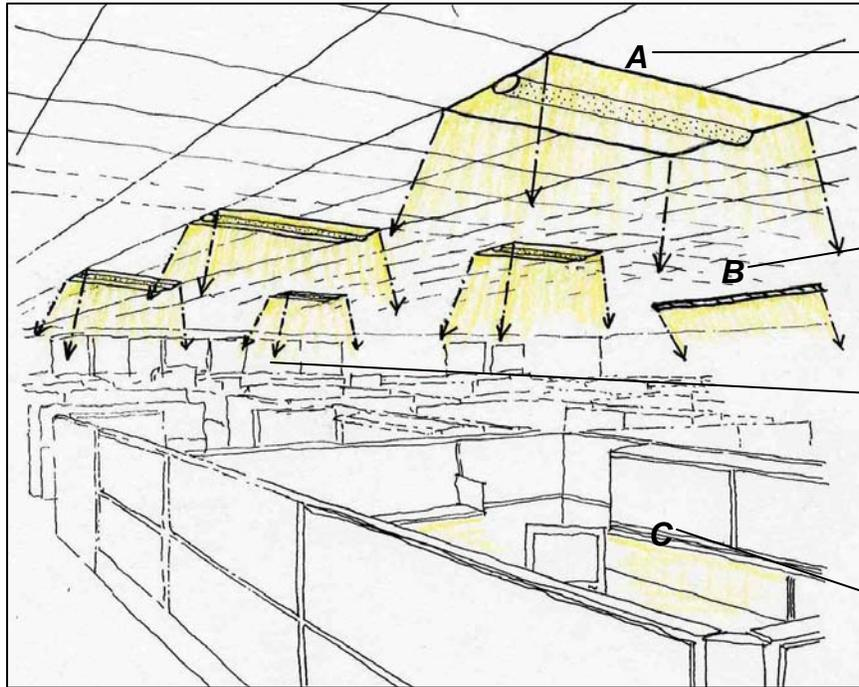
Undercabinet task lights increase illuminance on desks.

EQUIPMENT RECOMMENDATIONS:

	LUMINAIRE	LAMP	CONTROLS
A	Pendant mounted linear fluorescent, indirect / direct luminaire, mounted 0.5 – 0.9m (18” – 36”) below ceiling. (There are some luminaires available for ceiling heights of 8’ with short pendants.)	4’ linear fluorescent T8, T5HO lamps 3500K color temperature, 75 CRI +	Daylight dimming or switching. Manual dimming over workstations is also available. Consider the use of occupancy sensors for cubicle groups.
B	Under cabinet task lighting designed for minimal veiling reflections.	2’, 3’, and 4’ linear fluorescent T8 lamps 3500K color temperature, 75 CRI +	Manual on/off or on local occupancy sensor.

OFFICES

Open Offices (Alternate Scheme)



Recessed direct/indirect luminaires.

Recessed wallwashers increase surface brightness of walls.

Introduce daylight from north and south facades and control glare. Integrate daylight with electric lighting system where appropriate.

Undercabinet task lights increase illuminance on desks.

EQUIPMENT RECOMMENDATIONS:

	LUMINAIRE	LAMP	CONTROLS
A	Recessed linear fluorescent direct/indirect luminaire.	4' linear fluorescent T8, T5HO lamps 3500K color temperature, 75 CRI +	Daylight dimming or switching. Manual dimming over work stations is also available. Consider the use of occupancy sensors for cubicle groups.
B	Recessed compact or linear fluorescent wallwashers.	4' linear fluorescent T8, T5HO or compact fluorescent lamps 3500K color temperature, 75 CRI +	Daylight dimming or switching. Consider the use of occupancy sensors for cubicle groups.
C	Under cabinet task lighting.	2', 3', and 4' linear fluorescent T8, T5, or T2 lamps 3500K color temperature, 75 CRI +	Manual on/off or on local occupancy sensor.

CRITICAL DESIGN ISSUES:

- **Direct Glare:** Lamps in the luminaires are shielded with louvers, perforations, or lenses to avoid a view of the lamps and direct glare.
- **Luminances of Room Surfaces:** Room surfaces need to be illuminated to control the contrast between the occupant's task and the surrounding surfaces in that person's field of view. This is especially important with computer use when a person views a bright screen in the foreground. If the background is too dark the contrast will lead to eyestrain and fatigue. In a

large open office, the ceiling may be more prominent in someone's field of view than the walls.

- Uniformity: Luminance uniformity should not exceed 5:1 in immediate work surrounds, not including accent lighting.
- Reflected Glare: With high computer use, the ceiling brightness must be uniform to prevent reflected glare in computer screens. When viewing tasks with a glossy finish on a desktop, bright luminaire components such as visible lamps or lenses reflect in the surface of the task. This situation can make reading tasks annoying and at times impossible.
- Source / Task eye geometry: Task areas and luminaire locations need to be identified to avoid shadows and direct and reflected glare.
- Target Horizontal Illuminance ($\pm 10\%$): 30 lux (30 fc) ambient, 500 lux (50 fc) on the task.

DISCUSSION:

A task/ambient approach to the lighting in open offices results in separate control over an ambient system (typically a pendant mounted direct/indirect luminaire) and task lighting (a desk light or undercabinet luminaire). Design the under cabinet task light to minimize veiling reflections by directing light away from or to either side of the task. By providing a high illuminance level on the task only, and not the entire room, energy is saved in the ambient system, which does not have to produce as much light. This approach also provides a comfortable and flexible lighting environment. Manual dimming can also be incorporated with the use of remote controls at individual workstations that control only the nearby luminaires.

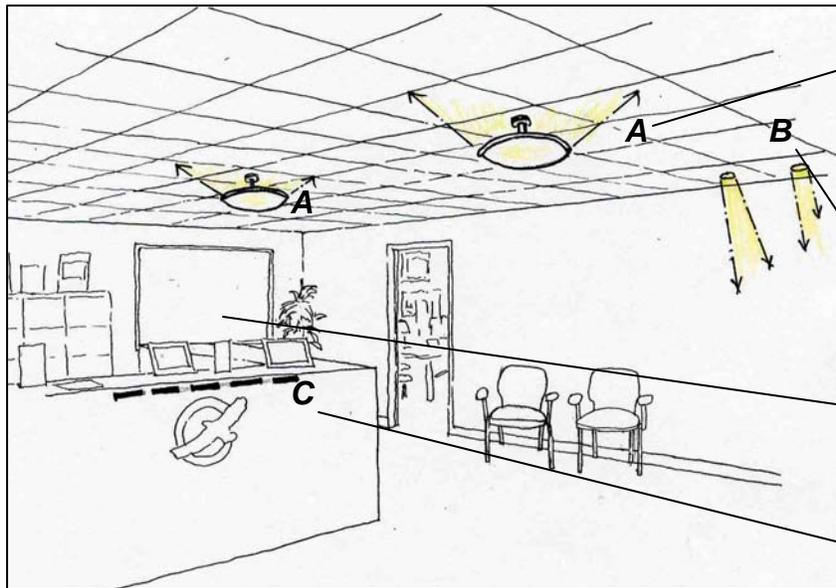
Integrating daylight with the electric lighting system greatly enhances the visual comfort of the space and can save significant amounts of energy. Depending on the configuration of workspaces and windows, lighting near the perimeter of the space may be controlled as a separate lighting zone from the lighting towards the interior of the space. In such a case, perimeter luminaires may be turned off entirely during the day while only using some portion of the lighting in the interior of the office.

RULES OF THUMB:

- Pendant spacing: When beginning a design, start with 3.0 – 3.7m (10 – 12 ft) spacing for T8 luminaires (5.5 – 6.0 m or 18 – 20 ft for T5HO systems) and modify accordingly to meet critical design issues.
- Pendant length: Pendant lengths range from 0.5 – 0.9 m (18 in – 3 ft). High performance luminaires may achieve a minimum of 0.3 m (12 in) pendant lengths. Specialty luminaires for low ceiling applications may be mounted even closer to the ceiling.
- Lighting Power Density: The lighting power density for open office areas can range from 0.9 – 1.2 watts /sq ft.

OFFICES

Waiting Areas



Pendant or surface mounted luminaires provide surface brightness and vertical illuminance.

Recessed wallwashers or accent lights increase wall brightness and highlight features.

Introduce and control daylight. Integrate with electric lighting system to reduce energy use.

Task lighting increases the illuminance on a task, allowing the ambient light levels to be lower.

EQUIPMENT RECOMMENDATIONS:

	LUMINAIRE	LAMP	CONTROLS
A	Pendant or surface mounted decorative luminaire.	Compact fluorescent lamps, 3500K color temperature, 80 CRI +	Consider daylight dimming or switching.
A ALT	Recessed direct / indirect linear fluorescent luminaire.	Linear fluorescent lamps, 3500K color temperature, 75+ CRI	Consider daylight dimming or switching.
B	Recessed compact fluorescent downlight/wallwasher.	Compact fluorescent lamps, 3500K color temperature, 80 CRI +	Consider daylight dimming or switching.
C	Linear fluorescent desk task lighting over desks.	2', 3', and 4' linear fluorescent T8, T5, or T2 lamps 3500K color temperature, 75 CRI +	Manual on / off or local occupancy sensor.

CRITICAL DESIGN ISSUES:

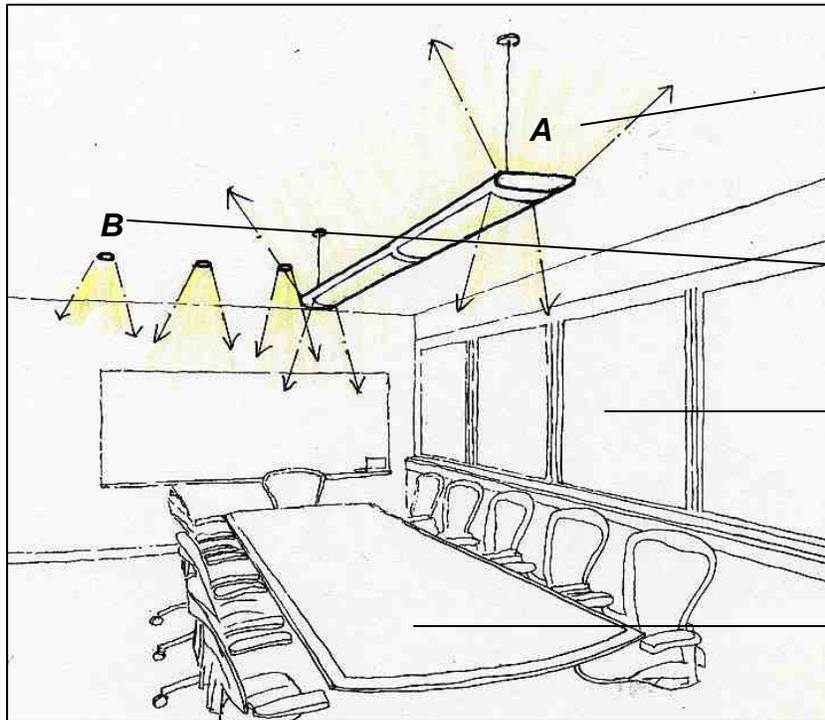
- Daylighting Integration and Control: If daylight can be introduced into waiting areas, the electric lighting can be turned off when there is adequate light.
- Appearance of Space and Luminaires: Because facility visitors often occupy waiting areas, the aesthetic appearance of the space and the luminaires is an important criterion.
- Target Horizontal Illuminance ($\pm 10\%$): 100 lux (10 fc) ambient, 500 lux (50 fc) on the task

DISCUSSION:

An effective and energy efficient lighting scheme illuminates high reflective surfaces as well as specific features in an ambient / accent approach. In the figure above, decorative pendants or surface mounted luminaires light the ceiling. This ambient system also can be easily integrated with the available daylight in the space. Wall washers illuminate walls and artwork. Because the walls make up a significant portion of our field of view, brightness on these surfaces increases the overall perceived brightness of the space.

OFFICES

Conference Rooms



Pendant mounted direct/indirect luminaires provide surface brightness and indirect ambient light.

Wallwashers light walls and / or whiteboards.

Introduce daylight from north and south facades and control glare. Provide horizontal blinds. Integrate with electric lighting system.

Luminaire over table provides uniform task illuminance.

EQUIPMENT RECOMMENDATIONS:

	LUMINAIRE	LAMP	CONTROLS
A	Pendant mounted linear fluorescent, indirect / direct luminaire, mounted 0.5 – 0.9m (18” – 36”) below ceiling	4’ linear fluorescent T8 lamps 3500K color temperature, 75 CRI +	Manual dimming or switching with occupancy sensors.
B	Recessed compact fluorescent downlight / wallwashers.	Compact fluorescent lamp. 3500K, 80+ CRI.	Manual on / off or manual on/ occupancy sensor off.

CRITICAL DESIGN ISSUES:

- Appearance of Space and Luminaires: Because building visitors often meet in conference rooms, the aesthetic character of the luminaires is an important consideration.
- Direct Glare: Lamps in the luminaires are shielded with louvers, perforations, or lenses to avoid a direct view of the lamps and the resultant glare.
- Light Distribution on Surfaces: Illuminate the room surfaces uniformly, especially the ceiling and walls. Patterns of light or shadows on surfaces can be distracting and confusing.
- Light Distribution on Task Plane: The lighting system should provide a uniform distribution of light on the conference table with minimal shadowing. This will provide a comfortable environment for writing tasks without causing fatigue or eyestrain.

- Luminance of Room Surfaces: Luminance, or brightness, of the room surfaces determines the perception of the conference room. With a bright, uniform ceiling and evenly washed walls, the space will feel bright and visually comfortable.
- Modeling of Faces or Objects: Because presentations and meetings are typical tasks in conference rooms, the lighting system should model people comfortably and accurately. Lighting that softly illuminates individual's faces without harsh shadows or excessive contrast reveals facial expressions and enhances such non-verbal communication.
- System Control and Flexibility: Control of luminaires should allow for multiple scenes or uses of the space. For example, a slide presentation may require lower ambient light levels, but adequate light on the table for occupants to take notes or read a handout. Window shades can darken the room for presentations. Other uses such as meetings may require more light.
- Target Horizontal Illuminance ($\pm 10\%$): 300-500 lux (30-50 fc)

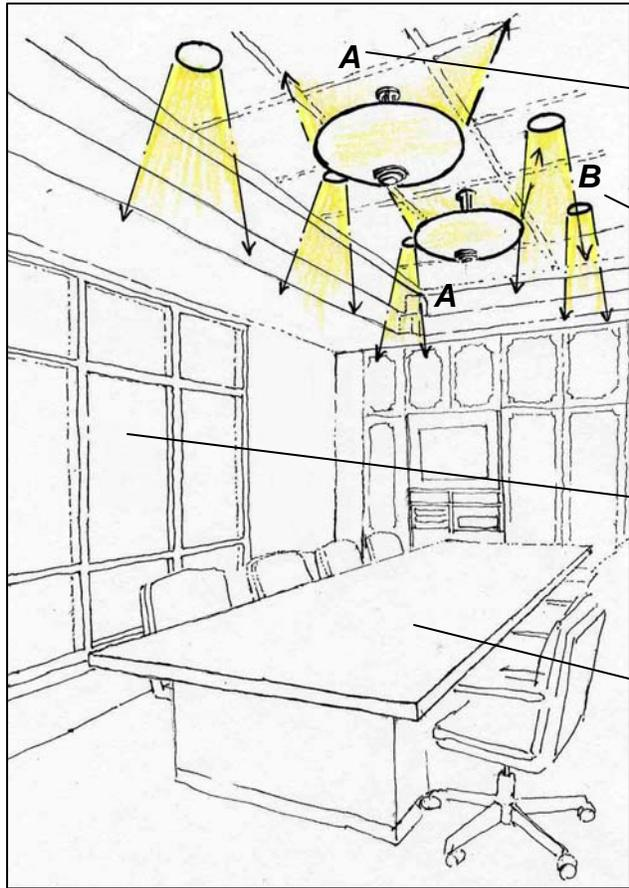
DISCUSSION:

The general ambient lighting must include an indirect component. A system comprised of downlighting only poorly illuminates room surfaces and puts harsh shadows on occupant's faces. Using an indirect component as part of the overall system will create a brighter space with better room surface luminances and render people more comfortably.

The lighting in a conference room should adapt to multiple uses of the space. At times, a presentation may require light on a white board or presentation wall. Other presentations may require a darker space for slide shows but still provide some light on the table so occupants can still take notes. For meetings, general lighting from a pendant over the table may be all that is required. Zone the luminaires separately to allow for the creation of multiple scenes depending on the space's use.

OFFICES

Boardrooms / Large Conference Rooms



Decorative pendants uplight ceiling and provide indirect ambient light.

Downlight / wallwashers increases room surface brightness.

Introduce daylight from north and south facades and control glare. Provide horizontal blinds. Integrate with electric lighting system.

Luminaires over the table provide uniform task illuminance.

EQUIPMENT RECOMMENDATIONS:

	LUMINAIRE	LAMP	CONTROLS
A	<i>Pendant mounted decorative fluorescent, indirect / direct luminaire.</i>	<i>Compact fluorescent lamp. 3500K, 80+ CRI.</i>	<i>Manual dimming or switching. Consider the addition of occupancy sensors.</i>
B	<i>Recessed compact fluorescent downlight / wallwashers.</i>	<i>Compact fluorescent lamp. 3500K, 80+ CRI.</i>	<i>Manual on / off. Consider the addition of occupancy sensors.</i>

CRITICAL DESIGN ISSUES:

- Appearance of Space and Luminaires: Because building visitors often meet in boardrooms and large conference rooms, the aesthetic character of the luminaires is an important consideration.
- Direct Glare: Lamps in the luminaires are shielded with louvers, perforations, or lenses to avoid a direct view of the lamps and the resultant glare.

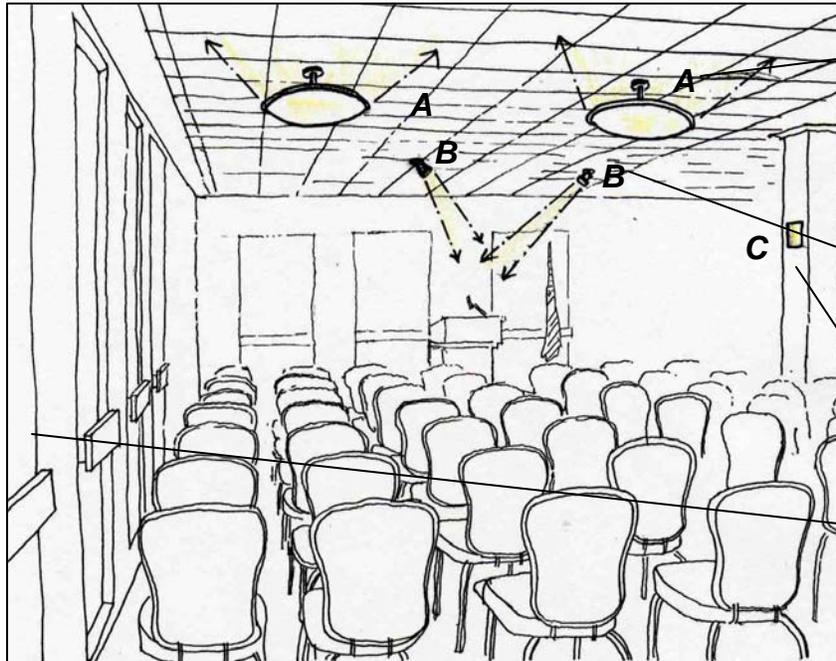
- Luminance of Room Surfaces: Luminance, or brightness, of the room surfaces determines the perception of the room. With a bright, uniformly lighted ceiling and evenly washed walls, the space will feel bright and visually comfortable. Increase brightness on architectural features or artwork to highlight certain areas.
- Modeling of Faces or Objects: Like conference rooms, presentations and meetings are typical tasks in boardrooms and the lighting system should model speakers as well as meeting participants. Lighting that softly illuminates individual's faces without harsh shadows or excessive contrast reveals facial expressions and enhances such non-verbal communication.
- Reflected Glare: When viewing tasks with a glossy finish on a tabletop, bright luminaire components, such as visible lamps or bright lenses reflect in the surface of the task. This situation can make reading tasks annoying and at times impossible.
- Target Horizontal Illuminance ($\pm 10\%$): 300-500 lux (30-50 fc)

DISCUSSION:

Similar to conference rooms, the lighting of boardrooms and large conference rooms should adapt to multiple uses of the space. At times, a presentation may require light on a white board or presentation wall. Other presentations may require a darker space for slide shows but still provide some light on the table so occupants can still take notes. For meetings, general lighting from a pendant over the table may be all that is required. Zone the luminaires separately to allow for the creation of multiple scenes depending on the space's use. Manual dimming allows a wide range of light levels for these varied requirements. Manual blinds for windows provide additional control over the daylight and ambient light levels.

OFFICES

Ceremonial Areas



Pendant mounted uplights provide indirect ambient light and surface brightness.

Adjustable accent lights highlight speaker or presentation.

Sconces provide visual interest and accent.

Introduce daylight from north and south facades and control glare. Provide horizontal blinds. Integrate with electric lighting system.

EQUIPMENT RECOMMENDATIONS:

	LUMINAIRE	LAMP	CONTROLS
A	Pendant mounted compact fluorescent uplight.	Compact fluorescent lamp. 3500K, 80+ CRI.	Control as a separate, dimmable zone or as part of a scene controller.
B	Surface or recessed adjustable accent light.	Tungsten halogen PAR spot or narrow floodlight.	Control as a separate, dimmable zone or as part of a scene controller.
C	Wall mounted compact fluorescent sconce.	Compact fluorescent lamp. 3500K, 80+ CRI.	Control as a separate, dimmable zone or as part of a scene controller.

CRITICAL DESIGN ISSUES:

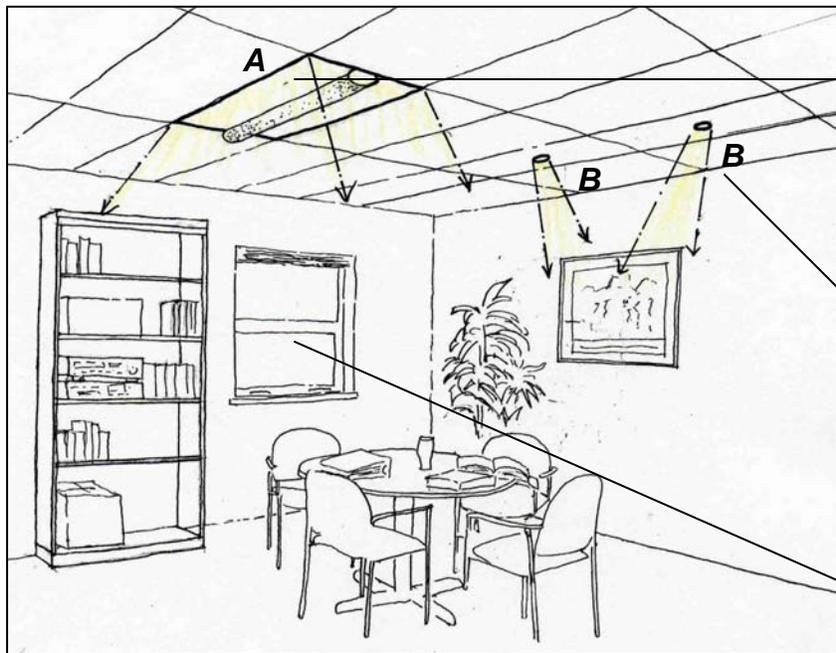
- Luminance of Room Surfaces: By lighting room surfaces, the ceremonial area will feel bright and comfortable. Balance contrast between surfaces with no brighter, accented surfaces. By keeping ambient lighting low, accent lighting on a speaker or presentation will be more effective.
- Modeling of Faces or Objects: Accent lighting on a speaker should come from multiple directions to eliminate harsh shadows and render faces or objects accurately.
- Target Horizontal Illuminance ($\pm 10\%$): 100 lux (10 fc) for ambient lighting.

DISCUSSION:

Similar to conference rooms or auditoriums, the lighting of ceremonial areas should adapt to multiple uses of the space. At times, a presentation may require accent light on a speaker. Other presentations may require dimmer lighting for slide shows. Manual or automated blinds for windows provide additional control over the daylight and ambient light levels. If the space is used for receptions or gatherings, a higher light level might be appropriate. Zone the luminaires separately to allow for the creation of multiple “scenes” depending on the space’s use.

OFFICES

Lounge Areas



Recessed direct / indirect luminaires provide ambient light and some ceiling brightness.

Wallwashing and accent lighting increases room surface brightness and highlights artwork and features.

Introduce and control daylight. Integrate with electric light controls to reduce energy use.

EQUIPMENT RECOMMENDATIONS:

	LUMINAIRE	LAMP	CONTROLS
A	<i>Recessed direct / indirect linear fluorescent luminaire.</i>	<i>Linear fluorescent T8 or T5HO lamps, 3500K color temperature, 75 CRI +</i>	<i>Daylight dimming or switching and occupancy sensor.</i>
B	<i>Recessed compact fluorescent downlight / wallwasher.</i>	<i>Compact fluorescent lamps, 3500K color temperature, 80+ CRI</i>	<i>Daylight dimming or switching and occupancy sensor.</i>

CRITICAL DESIGN ISSUES:

- **Daylighting Integration and Control:** The introduction of daylight into lounge areas can help to make it a more relaxing and inviting space. Use daylight controls to turn off unnecessary electric lighting.
- **Appearance of Space and Luminaires:** Select luminaires to enhance the appearance of the room and accent features of the space. Luminaire layout should avoid visual clutter of the space.
- **Luminance of Room Surfaces:** The room will feel bright if surfaces are illuminated. A recessed direct / indirect luminaire puts some light on the ceiling if the shielded “basket” drops below the ceiling plane. The use of downlight wallwashers highlights artwork or just adds to the overall brightness of the space.
- **Color Appearance (and Color Contrast):** The color of accent walls, architectural features, and artwork needs to be rendered accurately.

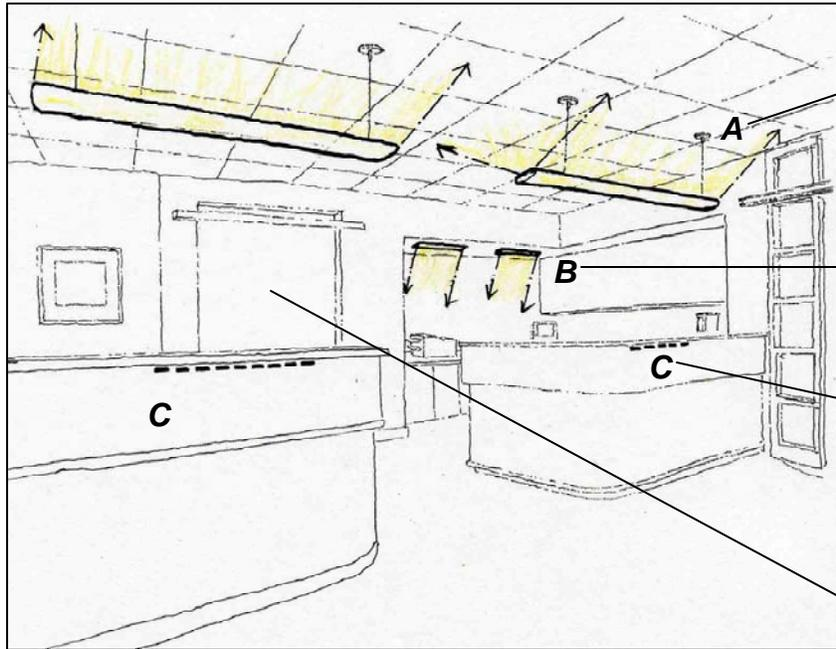
- Modeling of Faces or Objects: With casual conversation taking place in lounges, individual's faces should be illuminated well without harsh shadows.
- Target Horizontal Illuminance ($\pm 10\%$): 100 lux (10 fc)

DISCUSSION:

The introduction of daylight is a priority in lounge areas. Additionally, an ambient / accent approach to the lighting system will provide visual interest in the space and also some variety and flexibility in the control. While breaking the system into ambient and accent components, take care to avoid visual clutter with too many types of luminaires or poor layout. The luminaire selection should reinforce a casual and comfortable atmosphere.

OFFICES

Office Support Areas



Direct/indirect luminaires selected and located to prevent direct and reflected glare.

Recessed wallwashers increase wall brightness.

Task lighting increases the illuminance on a task, allowing the ambient light levels to be lower.

Introduce and control daylight on north and south facades. Integrate with electric light controls to reduce energy use.

EQUIPMENT RECOMMENDATIONS:

	LUMINAIRE	LAMP	CONTROLS
A	Pendant mounted linear fluorescent, indirect / direct luminaire, mounted 0.5 – 0.9m (18” – 36”) below ceiling	4’ linear fluorescent T8 lamps 3500K color temperature, 75 CRI +	Daylight or manual dimming or switching. Consider the use of occupancy sensors for cubicle groups.
B	Recessed linear fluorescent wall washer.	2’, 3’, and 4’ linear fluorescent T8 lamps 3500K color temperature, 75 CRI +	Manual on / off or local occupancy sensor.
C	Linear fluorescent desk task lighting over desks.	2’, 3’, and 4’ linear fluorescent T8, T5, or T2 lamps 3500K color temperature, 75 CRI +	Manual on / off or local occupancy sensor.

CRITICAL DESIGN ISSUES:

- **Direct Glare:** Visible lamps and bright lenses can cause glare, leading to eyestrain and eye fatigue.
- **Luminances of Room Surfaces:** Lighting the walls and the ceiling improves the perception of brightness in the space. It also reduces excessive contrast between surfaces that are in an occupant’s field of view.
- **Reflected Glare:** Bright lamps and lenses can be reflected in polished room surfaces, computer screens, and glossy printed tasks. These reflections reduce the contrast of tasks making reading extremely difficult. Shielding or diffusing lamps and specifying matte finishes where appropriate can improve the visual quality of the space and avoid reflected glare. Locate

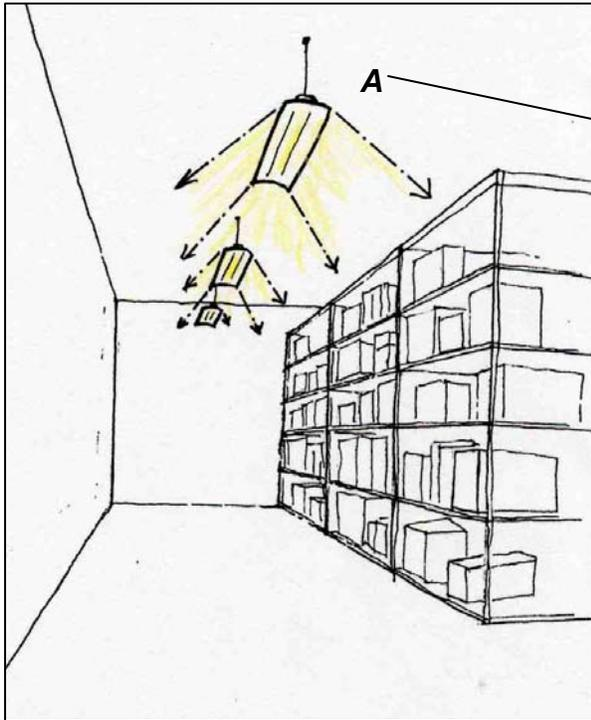
under-cabinet task lights to direct light away from or to either side of the task.

- Source / Task eye geometry: Identify task areas and design lighting to minimize shadows and glare (both direct and reflected).
- Target Horizontal Illuminance ($\pm 10\%$): 300 lux (30 fc) ambient, 500 lux (50 fc) on task.

DISCUSSION:

Office support areas require the same range of lighting levels as other office task spaces. By breaking the lighting system into ambient and task components, the ambient levels can be low while increasing the illuminance on the task only. This approach reduces energy consumption while giving occupants some flexibility and control over their workspace.

OFFICES



Pendant or surface mounted linear fluorescent industrial strips with a small uplight component illuminate shelves with minimal shadowing.

EQUIPMENT RECOMMENDATIONS:

	LUMINAIRE	LAMP	CONTROLS
A	<i>Pendant or surface mounted linear fluorescent luminaire.</i>	<i>4' linear fluorescent T8 lamps (or T5HO lamps for ceilings over 15') 3500K color temperature, 75 CRI +</i>	<i>Occupancy sensor or timer switch.</i>

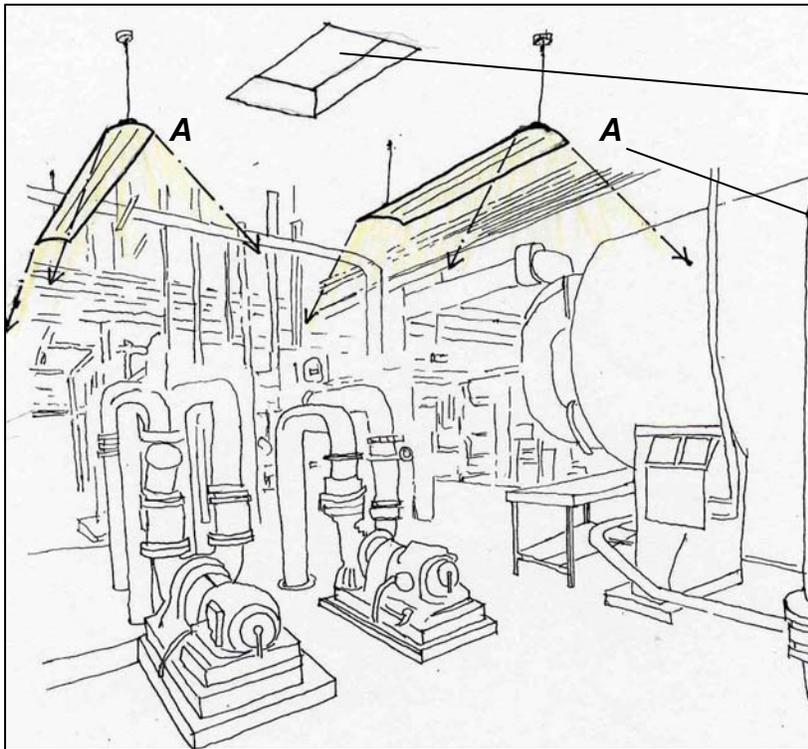
CRITICAL DESIGN ISSUES:

- Color Appearance (and Color Contrast): In storage rooms, individuals may need to locate and sort items. Lamp sources should have a high color-rendering index to accurately portray colors and labels.
- Source / Task eye Geometry: Locate luminaires to minimize direct glare and light shelves uniformly with minimal shadowing.
- Target Vertical Illuminance ($\pm 10\%$): 100 lux (10 fc)

DISCUSSION:

In storage rooms, uniform vertical illuminance on shelves helps with the identification of items. In small storage closets, a linear fluorescent strip mounted horizontally above the door provides indirect light and minimizes shadows on the shelves. Add wire guards to luminaires where they may be struck and damaged.

OFFICES



Consider daylight with toplighting strategies or clerestories.

Pendant mounted linear fluorescent luminaires, located to avoid mechanical equipment and minimize shadowing.

EQUIPMENT RECOMMENDATIONS:

	LUMINAIRE	LAMP	CONTROLS
A	Pendant mounted linear fluorescent industrial strip with 5%-10% uplight component.	4' linear fluorescent T8 lamps (or T5HO lamps for ceilings over 15') 3500K color temperature, 75 CRI +	Occupancy sensor or timer switch.

CRITICAL DESIGN ISSUES:

- Shadows: Locate and orient luminaires to avoid shadowing of mechanical equipment. Typically, equipment repair requires portable task lighting. Therefore, lighting should provide clear access to systems but not necessarily enough light to make repairs.
- Target Horizontal Illuminance (± 10%): 300 lux (30 fc)

DISCUSSION:

Adequate light needs to be provided for ease of navigation through mechanical rooms. Although mechanical rooms may not be used frequently or for long periods of time, if the lights are left on, a significant amount of energy can be wasted before the next use of the space. For larger spaces, consider the use of occupancy sensors. In small spaces, a control with a timer may be appropriate. Add wire guards to luminaires where they may be struck and damaged.

OFFICES



Surface mounted luminaires provide surface brightness on the ceiling.

Light at the mirror helps to illuminate faces.

EQUIPMENT RECOMMENDATIONS:

	LUMINAIRE	LAMP	CONTROLS
A	Surface or wall mounted compact fluorescent luminaire.	Compact fluorescent lamps, 3500K color temperature, 80 CRI +	Occupancy sensor.
B	Recessed linear fluorescent wall slot.	4' linear fluorescent T8 lamps 3500K color temperature, 75 CRI +	Occupancy sensor.

CRITICAL DESIGN ISSUES:

- Color Appearance (and Color Contrast): The color-rendering index of fluorescent lamps should be high to render colors well and avoid a pale or blue look to individual's faces.
- Modeling of Faces or Objects: With light coming from multiple directions and angles, faces and objects can be modeled well without harsh shadows.
- Target Horizontal Illuminance ($\pm 10\%$): 50 lux (5 fc), higher light level at mirrors

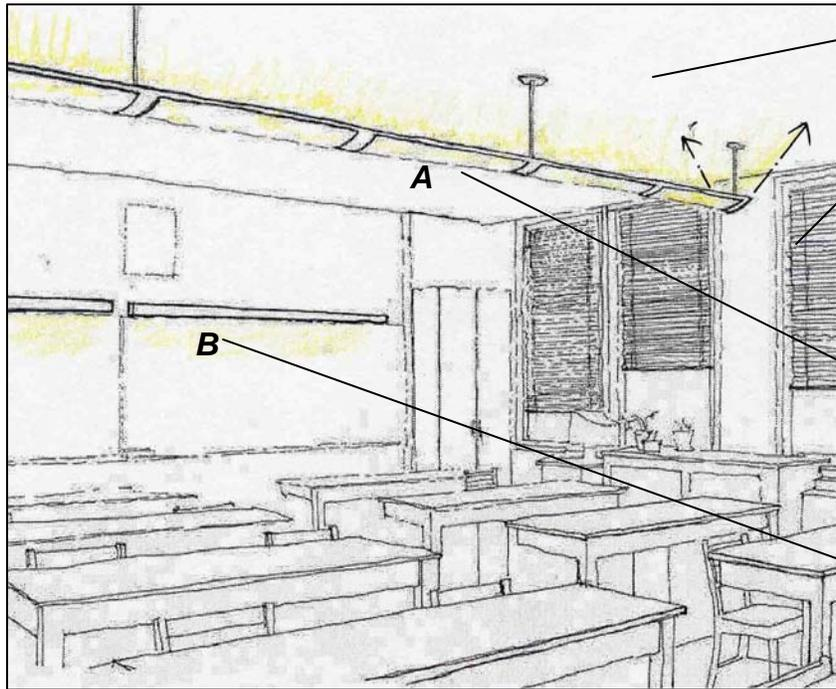
DISCUSSION:

While the recommended ambient light level for restrooms is low, lighting the walls and putting some brightness on the ceiling will increase the perceived brightness of the space. Increased light levels are appropriate at the sink or counter near the mirrors.

Occupancy sensors should control the lighting in restrooms where luminaires are frequently left on for an extended period of time. Ceiling mounted, ultrasonic sensors recognize occupants even in a space with high partitions. Locate and aim the sensor to switch on when the door opens and then turn off after a pre-determined amount of time.

EDUCATIONAL FACILITIES

Classrooms



Uniform ceiling brightness.

Introduce daylight (preferably on north and south facades) and control glare. Integrate with electric lighting system.

Pendant mounted direct / indirect luminaires selected and located to avoid direct and reflected glare.

Chalkboard light adds extra brightness to board when necessary.

EQUIPMENT RECOMMENDATIONS:

	LUMINAIRE	LAMP	CONTROLS
A	<i>Pendant mounted linear fluorescent, indirect / direct luminaire, mounted 0.5 -0.9m (18" – 36") below ceiling</i>	<i>4' linear fluorescent T8 or T5HO lamps, 3500K color temperature, 75 CRI +</i>	<i>Manual dimming or switching.</i>
B	<i>Linear fluorescent chalkboard light</i>	<i>4' linear fluorescent T8 or T5HO lamps, 3500K color temperature, 75 CRI +</i>	<i>Manual ON / OFF</i>

CRITICAL DESIGN ISSUES:

- **Daylight Integration:** Students perform better in classrooms with daylight. Good quality daylight that comes from south and north facing view windows and clerestories is preferred. Glare needs to be controlled, and lighting controls should reduce electric lighting when not required.
- **Direct Glare:** Since students are viewing the teacher and observing either whiteboard or overhead projector information, minimize glare from overhead electric lighting. Indirectly lighting the classroom with minimal direct light is the most effective glare free environment.
- **Reflected Glare:** Reflected glare occurs with overhead lighting reflecting on the student's desk and reading material. Indirectly lighting the classroom with minimal direct light reduces reflected glare.

- Light Distribution on Task Plane (Uniformity): Avoid uneven lighting such that some desks are significantly brighter than other desks. This occurs with either direct sunlight falling onto desks, or with recessed direct parabolics. Indirectly lighting the classroom with no more than 50% direct light provides the most uniform lighting.
- Horizontal and vertical illuminance: Horizontal illuminance is important for the student's desks. Vertical illuminance is important to view instructors, students, and the white boards.
- Target Horizontal Illuminance ($\pm 10\%$): 500 lux (50 fc)

DISCUSSION:

Multiple studies done show improved test scores (over 20%) with students who are in classrooms with daylight. Orient classrooms so that daylight can enter the classroom, preferably from two directions, without direct glare.

The electric lighting should light the ceiling in order to reduce direct and reflected glare potential. Yet, some direct light component is important to balance out the luminances within the classroom. The use of a white board light has been shown to improve student retention by highlighting written information.

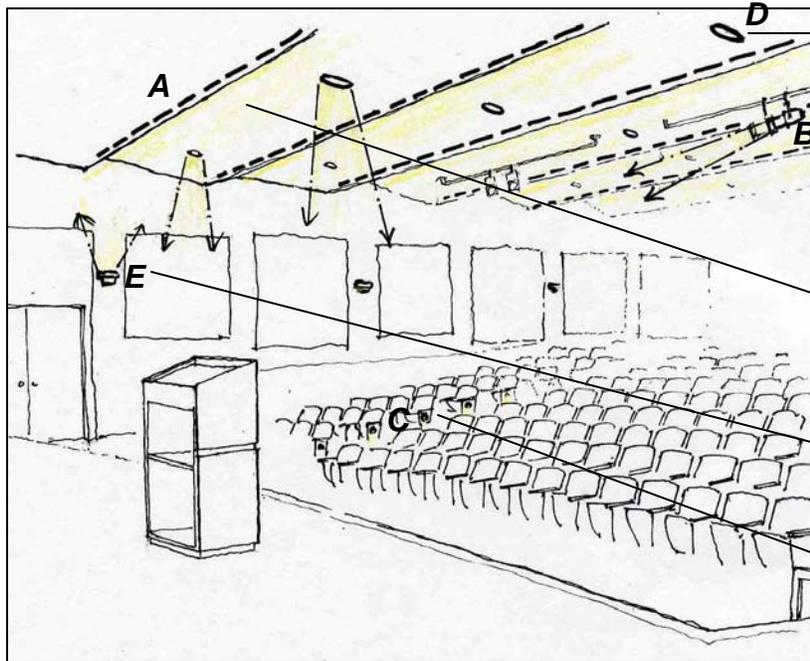
Controls in the classroom are also important, especially with the increase in computer projection. Giving the teacher the ability to dim the lighting provides enough light for note taking, yet minimizes the direct glare on the screen. Consider occupancy sensors for infrequently used classrooms.

RULES OF THUMB:

- Pendant spacing: When beginning a design, start with 3.0 – 3.7 m (10 – 12 ft) spacing for T8 fixtures and modify accordingly to meet critical design issues.
- Pendant length: Pendant lengths range from 0.5 – 0.9 m (18 in – 3 ft). High performance luminaires may achieve a minimum of 0.3 m (12 in) pendant lengths. Specialty luminaires for low ceiling applications may be mounted even closer to the ceiling.
- Lighting Power Density: The lighting power density for open office areas can range from 1.2 – 1.5 watts /sq ft for ambient connected load.

EDUCATIONAL FACILITIES

Auditoriums



- Downlights provide additional lighting for cleaning and maintenance.*
- Adjustable stage lighting illuminates speakers and presentations.*
- Concealed indirect lighting brightens surfaces and provides for ambient house lighting.*
- Decorative sconces add visual interest and sparkle.*
- Steplights provide minimal low level lighting for egress.*

EQUIPMENT RECOMMENDATIONS:

	LUMINAIRE	LAMP	CONTROLS
A	<i>Concealed linear fluorescent uplight.</i>	<i>4' linear fluorescent T8 or T5HO lamps, 3500K color temperature, 75 CRI +</i>	<i>Control as a separate zone or as part of an auditorium wide dimming control system.</i>
B	<i>Adjustable spotlight.</i>	<i>Tungsten halogen PAR38 spot or narrow floodlight.</i>	<i>Control as a separate zone or as part of an auditorium wide dimming control system.</i>
C	<i>Surface mounted steplight on edge of stair or in seats.</i>	<i>LED or fluorescent steplight.</i>	<i>Control as a separate zone or as part of an auditorium wide dimming control system.</i>
D	<i>Surface, recessed, or pendant mounted compact fluorescent downlight.</i>	<i>Compact fluorescent lamps, 3500K color temperature, 80 CRI +</i>	<i>Control as a separate zone or as part of an auditorium wide dimming control system.</i>
E	<i>Wall mounted compact fluorescent sconce.</i>	<i>Compact fluorescent lamps, 3500K color temperature, 80 CRI +</i>	<i>Control as a separate zone or as part of an auditorium wide dimming control system.</i>

CRITICAL DESIGN ISSUES:

- System Control and Flexibility: Auditorium controls should allow for a variety of scenes or lighting configurations. The system must provide for simple operation and require little or no training or special knowledge.

- Color Appearance and Color Contrast: Because speakers and presentations change, lamps should render color well. Additionally, the room surface finishes need to be carefully considered and illuminated with the appropriate lamp.
- Direct Glare: Since occupants are viewing the lecturer and observing presentation information, minimize glare from overhead electric lighting.
- Modeling of Faces and Objects: The speaker should be lighted with spotlights from both sides rather than straight on. This will prevent harsh shadows while still modeling the speaker's face. Such lighting increases the recognition of facial expressions and the effectiveness of non-verbal communication.
- Horizontal and Vertical Illuminance: Horizontal illuminance is important for the occupants taking notes. Vertical illuminance is important to view instructors, students, and presentations.
- Target Horizontal Illuminance ($\pm 10\%$): 100 lux (10 fc) for house ambient lighting; 500 lux (50 fc) for speaker lighting.

DISCUSSION:

The lighting for an auditorium should be made up of multiple components. This design approach allows users flexibility in controlling the lighting. It also saves energy by using only the lighting power that is required for a particular event or program. Additionally, this "system" approach (as well as the goal of lighting surfaces) encourages integration of light and architectural elements.

- Ambient Lighting: The ambient lighting may include multiple components to light the walls, ceiling, and other elements in the space. Recessed coves or suspended pendant uplights might light the ceiling surface. Acoustic panels may form coves for indirect lighting. Additional ambient lighting may occur at the perimeter of the auditorium in the form of wall washing.
- House Lighting: Downlights can provide additional house lighting for maintenance and cleaning or at a time when higher light levels are required. In combination with the ambient lighting, an illuminance range of up to 300 lux (30 fc) could be achieved.
- Stage Lighting: Stage lighting will highlight a lecturer and presentation.

Egress Lighting: Lighting along the edge of the aisles or possibly in the chairs can illuminate the aisles to some minimum level during a presentation to allow for safe egress.

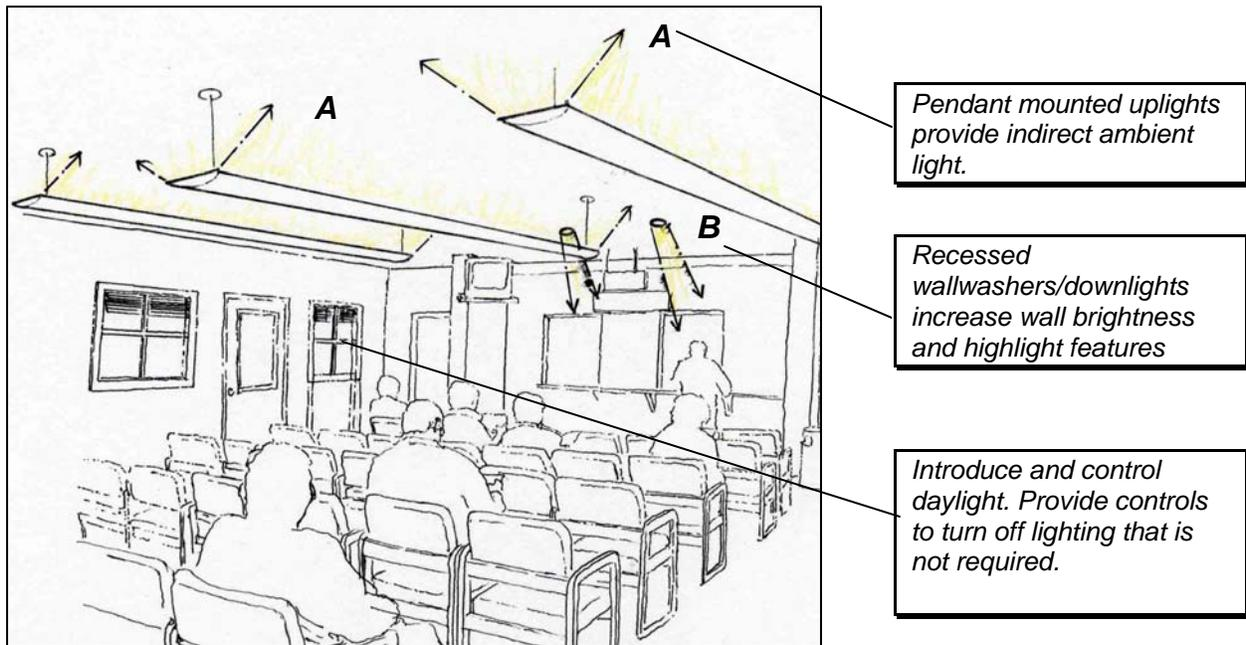
With the lighting for the space divided into multiple components (or zones), these zones can then be configured with a control system to make up preset "scenes". Each scene is a combination of different zones set to "on" (or "off") and dimmed to a selected level of light. This selected combination corresponds to a particular event or program. Once the scenes are programmed, the push of one button raises and lowers all of the lights to

their predetermined levels. The following outlines some typical events that could be assigned a preset scene:

- Pre / Post Lecture: Ambient lighting may be on full; stage lighting could be off or dimmed to a low level; egress lighting would be off.
- Lecture: Ambient and house lighting may be dimmed to a low level or on enough for note taking; stage lighting would light the speaker; egress lighting would be on.
- AV / ITV Presentation: Ambient and house lighting would be very low or off and still adequate for note taking; stage lighting would be off to accommodate the AV presentation; egress lighting would be on.
- Cleaning / Maintenance: Ambient and house lighting would be on full; stage lighting would be on; egress lighting would be off.

HEALTHCARE FACILITIES

Waiting Rooms



EQUIPMENT RECOMMENDATIONS:

	LUMINAIRE	LAMP	CONTROLS
A	Pendant mounted linear fluorescent indirect / direct luminaire.	4' linear fluorescent T8 lamps, 3500K color temperature, 75 CRI+	Daylight dimming or switching.
A ALT	Pendant mounted decorative compact fluorescent uplight.	Compact fluorescent lamps, 3500K color temperature, 80 CRI +	Daylight dimming or switching.
B	Recessed compact fluorescent downlight / walwashers	Compact fluorescent lamps, 3500K color temperature, 80 CRI +	Control accent lighting separately from ambient light.

CRITICAL DESIGN ISSUES:

- **Daylighting Integration and Control:** The introduction of daylight into waiting rooms provides a connection to the outdoors as well as a potential lighting energy savings. By integrating controls with the daylight design, electric lighting equipment can be turned off when not required.
- **Appearance of Space and Luminaires:** Because waiting rooms are often the first space visitors to the facility see, the aesthetic appearance of the space and the luminaires is an important criterion.
- **Luminance of Room Surfaces:** Lighting the wall and ceiling surfaces can achieve increased brightness with less energy. Typically people may be reading or watching TV in such spaces and are not occupied with difficult

visual tasks. Therefore, the luminances of the surfaces are far more important than the horizontal illuminance.

- Target Horizontal Illuminance ($\pm 10\%$): 100 lux (10 fc)

DISCUSSION:

As in most interior spaces, waiting areas require the lighting of surfaces to increase the perceived brightness. By utilizing an indirect pendant, the lighting system illuminates the ceiling surface and provides indirect ambient light. This comfortable light minimizes shadows and also avoids glare from the light source. The indirect lighting of surfaces also integrates well with daylight. In some designs, luminaires close to windows may be controlled separately and switched off during times of the day when daylight provides adequate brightness in the space.

HEALTHCARE FACILITIES



Recessed direct/indirect luminaire minimizes direct glare.

Under shelf task lights provide higher light levels on counter.

EQUIPMENT RECOMMENDATIONS:

	LUMINAIRE	LAMP	CONTROLS
A	<i>Recessed indirect / direct linear fluorescent luminaire.</i>	<i>4' linear fluorescent T8 lamps, 3500K color temperature, 75 CRI+</i>	<i>Control ambient and task lighting separately.</i>
A ALT	<i>Recessed parabolic linear fluorescent luminaire.</i>	<i>4' linear fluorescent T8 lamps, 3500K color temperature, 75 CRI+</i>	<i>Control ambient and task lighting separately.</i>
B	<i>Under shelf linear fluorescent task light.</i>	<i>2', 3', and 4' linear fluorescent T8, T5, T2 lamps, 3500K color temperature, 75 CRI+</i>	<i>Control ambient and task lighting separately.</i>

CRITICAL DESIGN ISSUES:

- Color Appearance (and Color Contrast): Task and ambient lighting should accurately render colors of medication.
- Direct Glare: Shield lamps with diffusers, lenses, or louvers to eliminate direct glare.
- Flicker (and Strobe): Flicker of fluorescent lamps can become an annoyance to anyone under them for an extended period of time. While sensitivity to flicker varies dramatically between individuals, electronic ballasts typically avoid this problem.
- Light Distribution on Task Plane (Uniformity): Uniformly illuminate the task plane as well as room surfaces, without shadows or confusing patterns of light.

- Modeling of Faces and Objects: The use of direct/indirect light or light from multiple directions fills in shadows and renders texture and three-dimensional objects.
- Reflected Glare: Select and locate luminaires to avoid veiling reflections on the countertop. Such reflected glare will impair viewing of tasks on the counter. Locate under-shelf task lights to direct light away from or to either side of the task.
- Horizontal and Vertical Illuminance: Adequate illuminance levels need to be provided for both horizontal tasks on the counter as well as vertical tasks on shelves or equipment.
- Target Horizontal Illuminance ($\pm 10\%$): 500 lux (50 fc)

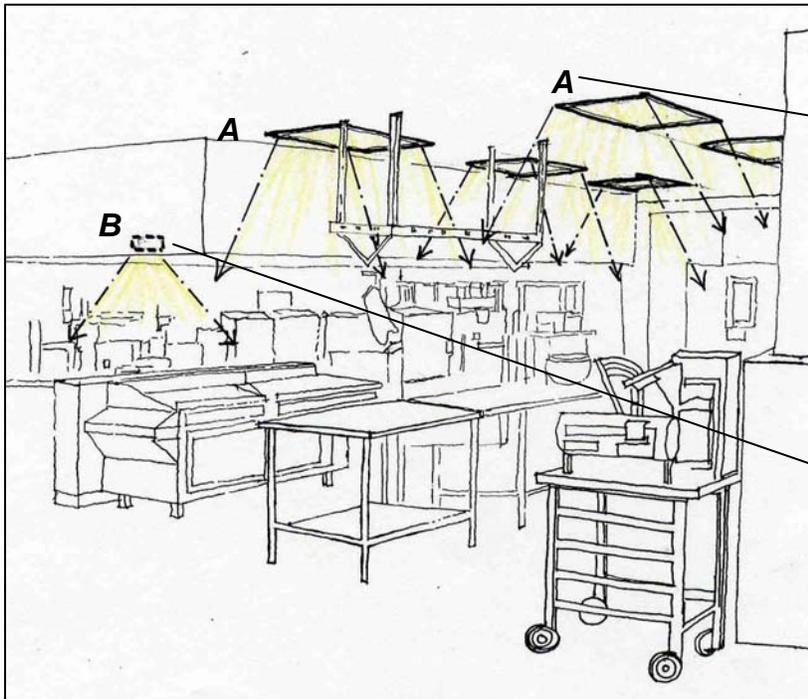
DISCUSSION:

While pharmaceutical tasks require a high light level, a task-ambient system reduces the amount of light that needs to be provided by the ambient system. Task lighting then increases the light level where and when it is required.

Recessed ambient lighting equipment often fails to provide the surface brightness necessary for a comfortable visual environment. Spending all day in such an environment can lead to eyestrain and fatigue. Surface brightness can be improved by utilizing the benefits of an indirect / direct luminaire or lens to put more light on the ceiling or walls. Additionally, wallwashers, where appropriate, illuminate fixed shelves, or improve the room surface brightness.

FOOD SERVICE

Kitchens



Recessed lensed luminaires provide high illuminance levels on the work plane.

Compact fluorescent luminaires located inside hood provide additional lighting over grill.

EQUIPMENT RECOMMENDATIONS:

	LUMINAIRE	LAMP	CONTROLS
A	<i>Recessed linear fluorescent downlight with gasketed lens.</i>	<i>4' linear fluorescent T8 or T5HO lamps, 3500K color temperature, 75 CRI+</i>	<i>Control ambient and task lighting separately.</i>
B	<i>Surface mounted linear or compact fluorescent task light under counter or under hood. (Often procured as part of the hood.)</i>	<i>Linear or compact fluorescent lamps, 3500K color temperature, 75 CRI+</i>	<i>Control ambient and task lighting separately.</i>

CRITICAL DESIGN ISSUES:

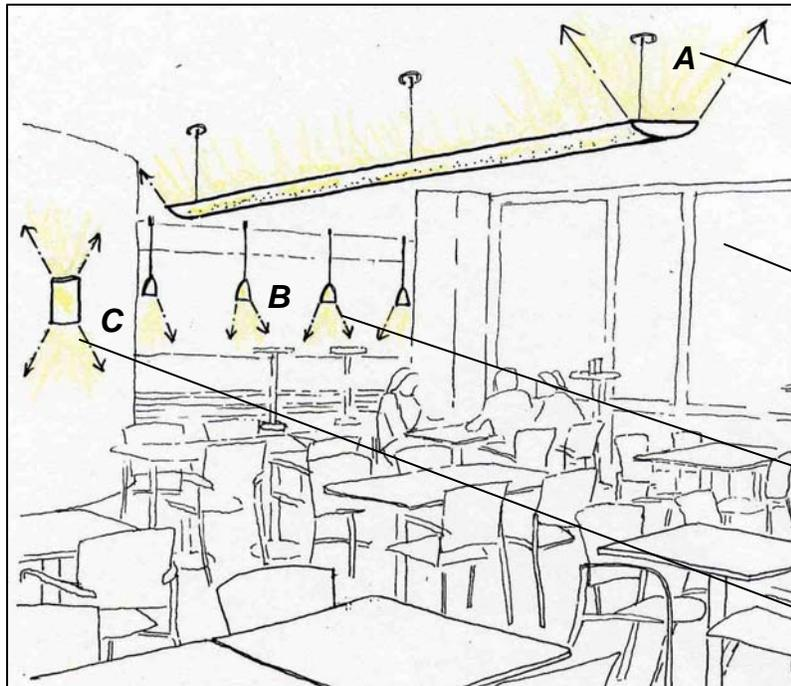
- **Color Appearance:** The color of food should be accurately rendered with high color-rendering index fluorescent lamps.
- **Reflected Glare:** If lighting is improperly placed directly in front of the cook, reading recipes and preparing food can be a challenge. Minimize reflected glare with proper lighting equipment locations.
- **Shadowing:** Minimize contrast with ambient and task lighting to fill in shadows. This is especially important on work surfaces where people will be using knives and other kitchen tools.
- **Source / Task Eye Geometry:** Overhead ambient lighting and under-counter task lighting will minimize confusing shadows. Locate luminaires so that shadows are minimized and the light is where it is needed.

- Target Horizontal Illuminance ($\pm 10\%$): 500 lux (50 fc) on cooking and food preparation surfaces. A task light is often provided with grill hoods. Verify that it will provide adequate illuminance on the cooking surface.

DISCUSSION:

Because kitchens require high light levels with minimal shadowing, a diffuse direct system is a good choice. Recessed lensed and gasketed luminaires typically provide a high light level and allow for easy maintenance. Additional task lighting under cabinets and under exhaust hoods increases the task illuminance and fills in shadows on the task plane. Refer to UFC 4-722-01 for additional requirements.

FOOD SERVICE



Indirect / direct luminaires light the ceiling while still providing a small direct component.

Daylight should be introduced into the space, controlled, and integrated with the electric lighting.

Low wattage accent lighting helps to highlight points of interest.

Wall sconces provide surface brightness and visual interest.

EQUIPMENT RECOMMENDATIONS:

	LUMINAIRE	LAMP	CONTROLS
A	<i>Linear fluorescent indirect / direct luminaire.</i>	<i>4' linear fluorescent T8 or T5HO lamps, 3000K color temperature, 75 CRI+</i>	<i>Control with daylight sensors.</i>
B	<i>Pendant mounted low voltage decorative accent light.</i>	<i>Low voltage, directional lamps.</i>	<i>Control ambient and accent lighting separately. Consider the use of occupancy sensors.</i>
C	<i>Wall mounted compact fluorescent sconce.</i>	<i>Compact fluorescent lamp, 3000K color temperature, 80 CRI+</i>	<i>Control ambient and accent lighting separately. Consider the use of occupancy sensors.</i>

CRITICAL DESIGN ISSUES:

- **Color Appearance:** The appearance of food served in a cafeteria should be vivid and aesthetically pleasing. Often halogen lamps illuminate food at the point of display. Where fluorescent lamps are used, they should be specified with a high color-rendering index (CRI).
- **Modeling of Faces or Objects:** The modeling of food texture and appearance is especially important where it is displayed and served. Directional accent light, in addition to the ambient light, highlights the food and provides adequate modeling.
- **Point(s) of Interest:** Accent lighting should focus attention and provide some level of way finding and direction for occupants. Accenting signs and

special sections creates visual interest in the space as well as guidance through a serving line.

- Direct Glare: When minimizing glare, consider direct views from the cafeteria or serving area (a relatively low light level) into a kitchen with a relatively high light level. Additionally, accent lighting should attract attention without becoming a glare source.
- Target Horizontal Illuminance ($\pm 10\%$): 100 lux (10 fc); 500 lux (50 fc) on food display

DISCUSSION:

The lighting system in a cafeteria should create a visually comfortable environment with occasional accent lighting to add interest to the space and assist in way finding. It is important to note that accent lighting can only be effective when the ambient light level is lower. People see and respond to *changes* in brightness. A highlighted area must be between three and five times brighter than the surroundings to be perceived as a brighter area. A high ambient light level makes accent lighting nearly impossible without using an enormous amount of energy.

If daylight can be introduced into the space, it should be controlled to reduce glare and heat gain. Additionally, integrate control of the electric lighting system with the available daylight with sensors and dimmers or switches to reduce the amount of lighting energy consumed when it is not required. Refer to UFC 4-722-01 for additional requirements.

FOOD SERVICE

Enlisted Dining Rooms



Wall mounted uplights provide indirect lighting and uniform ceiling brightness.

Pendant mounted luminaire over tables creates decorative accent lighting.

Introduce daylight and control glare. Integrate with electric lighting system.

EQUIPMENT RECOMMENDATIONS:

	LUMINAIRE	LAMP	CONTROLS
A	Wall mounted indirect compact fluorescent luminaire.	Linear or compact fluorescent lamps, 3000K color temperature, 75 CRI+	Integrate control of luminaires with available daylight.
B	Pendant mounted compact fluorescent luminaire.	Compact fluorescent lamps, 3000K color temperature, 80 CRI+	Integrate control of luminaires with available daylight.

CRITICAL DESIGN ISSUES:

- **Color Appearance:** The appearance of food served in the dining areas should be vivid and aesthetically pleasing. Often halogen lamps illuminate food at a point of display. Where fluorescent lamps are used, they should be specified with a high color-rendering index (CRI).
- **Modeling of Faces or Objects:** The modeling of food texture and appearance is especially important where it is displayed and served. Directional accent light, in addition to the ambient light, highlights the food and provides adequate modeling.
- **Direct Glare:** Avoid excessive luminaire brightness in dining rooms where people will be sitting for long periods of time. Accent lighting should use low wattage lamps and be aimed to minimize direct glare.
- **Target Horizontal Illuminance ($\pm 10\%$):** 100 lux (10 fc); 500 lux (50 fc) on food display

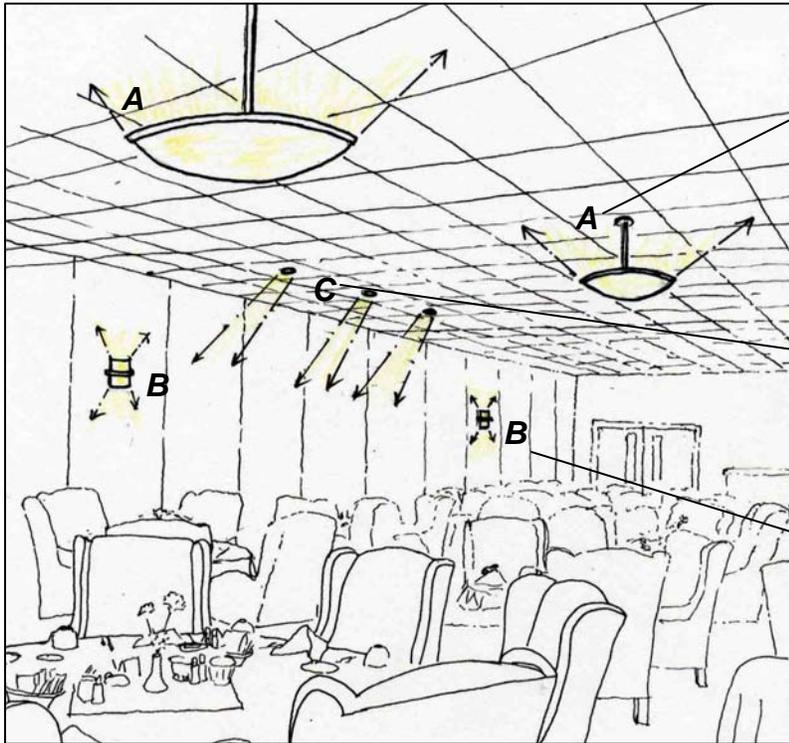
DISCUSSION:

The lighting system in a dining area should provide a soft ambient light and a visually comfortable environment with occasional accent lighting to add interest to the space. It is important to note that accent lighting can only be effective when the ambient light level is low enough for a contrast to be noticeable. People see and respond to *changes* in brightness. A highlighted area must be between three and five times brighter than the surroundings to be perceived as a brighter area. A high ambient light level makes accent lighting nearly impossible without using an enormous amount of energy.

Pendants over serving tables add a decorative accent, but should not consume a lot of energy. This decorative effect can be achieved with a very low wattage lamp. Additionally, because the pendant may be in someone's field of view, a low wattage lamp will prevent direct glare. Refer to UFC 4-722-01 for additional requirements.

FOOD SERVICE

Officer Dining Rooms



Pendant mounted decorative luminaires provide indirect ambient lighting.

Recessed compact fluorescent downlight / wallwashers add surface brightness and highlight features.

Wall sconces add visual interest.

EQUIPMENT RECOMMENDATIONS:

	LUMINAIRE	LAMP	CONTROLS
A	<i>Pendant mounted decorative fluorescent uplight.</i>	<i>Compact fluorescent lamps, 3000K color temperature, 80 CRI+</i>	<i>Control ambient and accent lighting separately. Provide dimming.</i>
B	<i>Wall mounted compact fluorescent sconce.</i>	<i>Compact fluorescent lamps, 3000K color temperature, 80 CRI+</i>	<i>Control ambient and accent lighting separately.</i>
C	<i>Recessed compact fluorescent downlight wallwasher.</i>	<i>Compact fluorescent lamps, 3000K color temperature, 80 CRI+</i>	<i>Control ambient and accent lighting separately. Provide dimming.</i>

CRITICAL DESIGN ISSUES:

- **Color Appearance (and Color Contrast):** The appearance of food served in the dining areas should be vivid and aesthetically pleasing. Often halogen lamps illuminate food at a point of display. Where fluorescent lamps are used, they should be specified with a high color-rendering index (CRI).
- **Appearance of Space and Luminaires:** Because officer dining rooms may also host guests from time to time, carefully consider the aesthetic character and appearance of the lighting equipment. Additionally, consider the surfaces and features of the space that should be accented and illuminated.
- **Modeling of Faces or Objects:** The modeling of food texture and appearance is especially important where it is displayed and served.

Additionally, lighting should illuminate the diners softly and provide adequate modeling of their faces.

- Direct Glare: Avoid excessive luminaire brightness in dining rooms where people will be sitting for long periods of time.
- Target Horizontal Illuminance ($\pm 10\%$): 100 lux (10 fc); 500 lux (50 fc) on food display

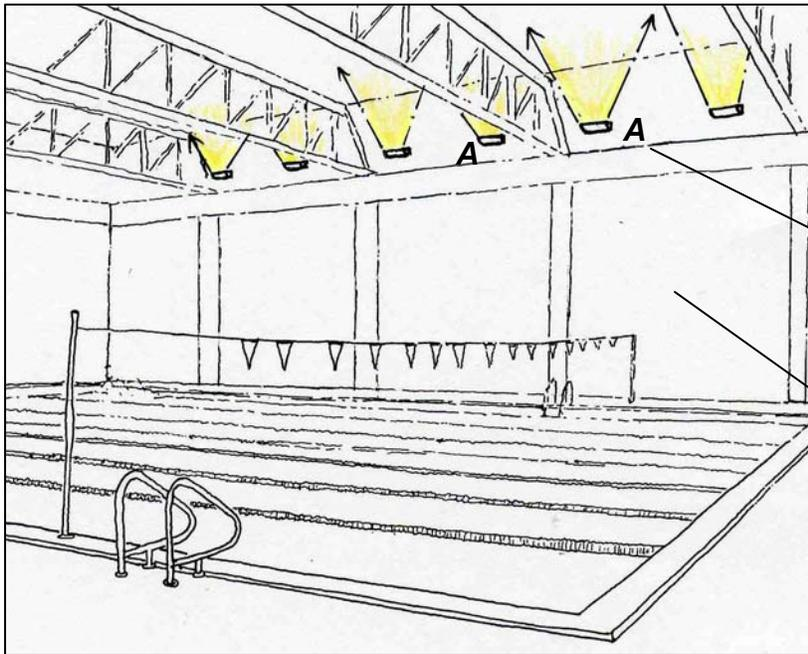
DISCUSSION:

The lighting system in officers' dining areas should provide a soft ambient light and a visually comfortable environment with occasional accent lighting to add visual interest to the space. It is important to note that accent lighting can only be effective when the ambient light level is low enough for a contrast to be noticeable. The human eye sees and responds to *changes* in brightness. A highlighted area must be between three and five times brighter than the surroundings to be perceived as a brighter area. A high ambient level makes accent lighting nearly impossible without using an enormous amount of energy. Carefully choose the surfaces and architectural features that are accented for the desired effect.

Pendants over tables add a decorative accent, but should not consume a lot of energy. This decorative effect can be achieved with a very low wattage. Additionally, because the pendant may be in someone's field of view, a low wattage lamp will avoid direct glare. Dimming control provides a range of light levels and allows for multiple lighting "scenes". Refer to UFC 4-722-01 for additional requirements.

RECREATIONAL FACILITIES

Indoor Swimming Pools



*Indirect ambient light
minimizes direct and reflected
glare.*

*Introduce and control daylight.
Integrate available daylight
with electric lighting system.*

EQUIPMENT RECOMMENDATIONS:

	LUMINAIRE	LAMP	CONTROLS
A	<i>Wall mounted uplight.</i>	<i>Metal halide.</i>	<i>Manual on/off or controlled with daylight.</i>

CRITICAL DESIGN ISSUES:

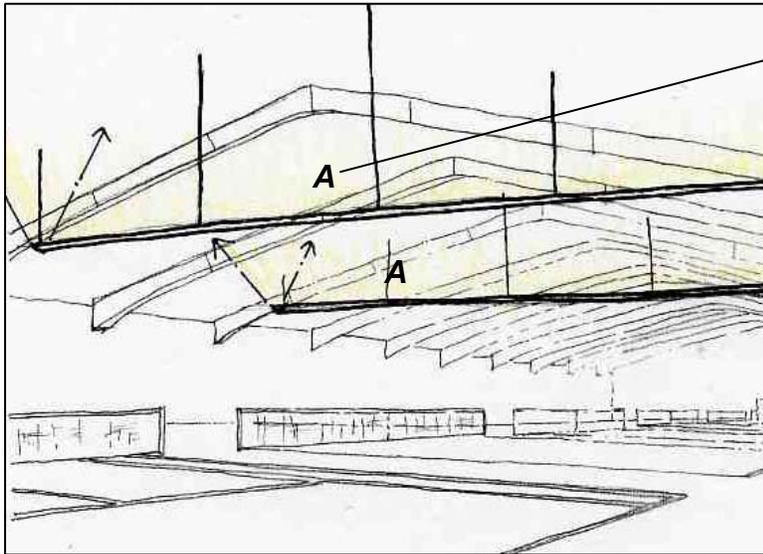
- Direct Glare: Select, locate and shield luminaires to avoid direct glare.
- Reflected Glare: Select luminaires to avoid a direct component that would result in direct glare. This is especially important considering that the water and a wet deck provide specular surfaces.
- Target Horizontal Illuminance ($\pm 10\%$): For recreational class of play: 300 lux (30 fc). For other classes of play, see IESNA RP-6. Refer to UFC 4-740-02N for additional requirements.

DISCUSSION:

The lighting design should avoid direct and reflected glare on the water surface. Also consider maintenance and accessibility. Locate luminaires above the deck and at the edge of the pool to allow for access and relamping.

RECREATIONAL FACILITIES

Indoor Tennis Courts



Pendant mounted indirect ambient light minimizes shadowing and prevents direct glare.

Introduce and control daylight. Integrate available daylight with electric lighting system.

EQUIPMENT RECOMMENDATIONS:

	LUMINAIRE	LAMP	CONTROLS
A	<i>Pendant mounted linear fluorescent indirect/direct luminaire</i>	<i>4' linear fluorescent T8 or T5HO lamps, 3500K color temperature, 75 CRI+</i>	<i>Manual on/off or integrate with daylight.</i>

CRITICAL DESIGN ISSUES:

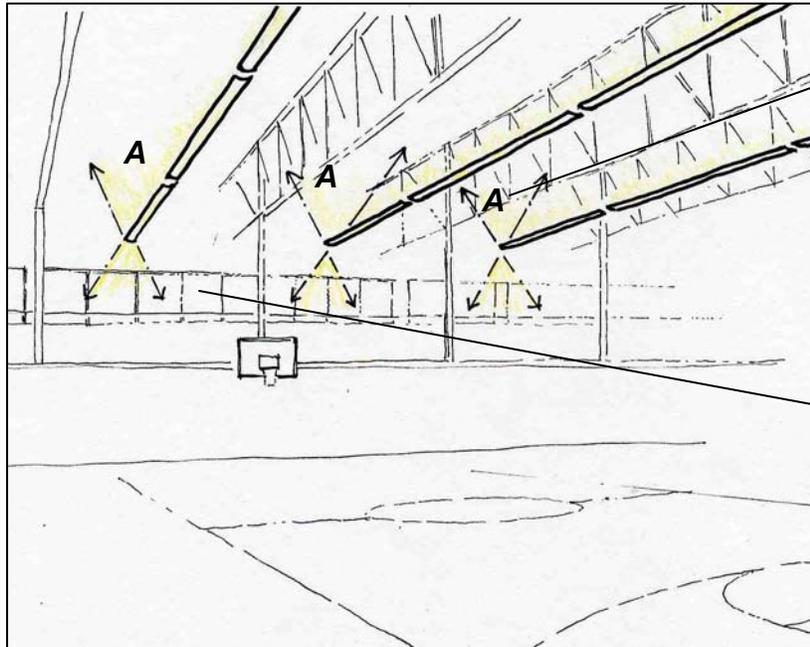
- **Direct Glare:** Locate and shield or lens luminaires to avoid direct glare. With indirect fluorescent luminaires this is not an issue.
- **Flicker (and Strobe):** Flicker and strobe of fluorescent luminaires is generally not an issue when using electronic ballasts. If it does occur, it can impair the viewing of high-speed objects such as a tennis ball.
- **Light Distribution on Task Plane (Uniformity):** The lighting system needs to uniformly illuminate the court. Any dark spots or patterns of light will create confusing and distracting areas.
- **Target Horizontal Illuminance ($\pm 10\%$):** For recreational class of play: 500 lux (50 fc). For other classes of play, see IESNA RP-6. Refer to UFC 4-740-02N for additional requirements.

DISCUSSION:

Traditionally tennis courts are illuminated with metal halide lamps. While this is a common solution, indirect T5HO fluorescent uplights can provide a much better visual environment. Additionally, the initial cost of the system is the same or less expensive than a metal halide system and the fluorescent maintenance and energy costs are lower. When daylight is plentiful, the fluorescent lighting can be dimmed or turned off.

RECREATIONAL FACILITIES

Indoor Basketball Courts



Pendant mounted direct/indirect lights minimize shadowing and prevent direct glare.

Introduce and control daylight. Integrate available daylight with electric lighting system.

EQUIPMENT RECOMMENDATIONS:

	LUMINAIRE	LAMP	CONTROLS
A	<i>Pendant mounted linear fluorescent luminaire (50% direct / 50% indirect)</i>	<i>4' linear fluorescent T8 or T5HO lamps, 3500K color temperature, 75 CRI+</i>	<i>Manual on/off or integrate with daylight.</i>

CRITICAL DESIGN ISSUES:

- Direct Glare: Locate and shield or lens equipment to avoid direct glare.
- Light Distribution on Task Plane (Uniformity): The lighting system needs to uniformly illuminate the court. Any dark spots or patterns of light will create a confusing and distracting area.
- Reflected Glare: Polished wood floors can reflect the image of the lamp above causing an annoying distraction.
- Shadows: Minimize shadows to enhance the view of the ball and other players.
- Target Horizontal Illuminance ($\pm 10\%$): For recreational class of play: 300 lux (30 fc). For other classes of play, see IESNA RP-6. Refer to UFC 4-740-02N for additional requirements.

DISCUSSION:

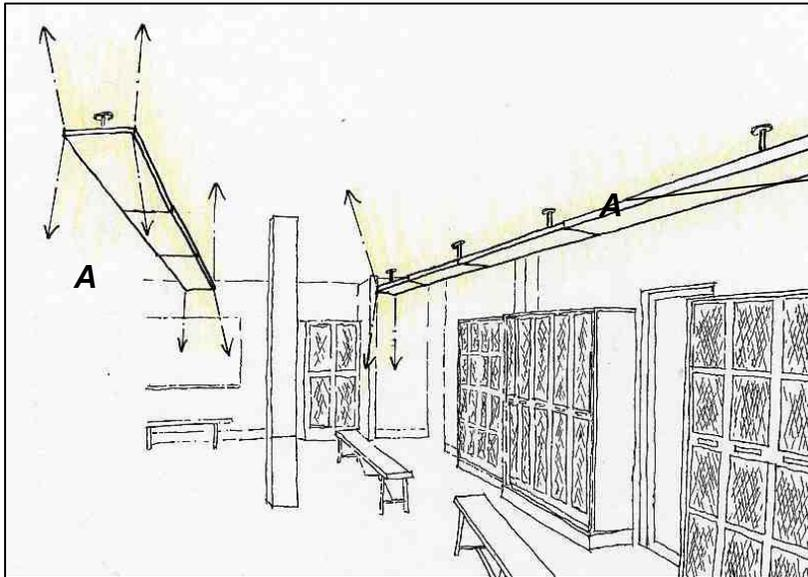
Traditionally basketball courts and gymnasiums are illuminated with metal halide lamps. While this is a common solution, indirect T5HO fluorescent uplights can provide a much better visual environment. Such a system reduces direct and reflected glare.

Additionally, the initial cost of the system is the same or less expensive than a metal halide system and the fluorescent maintenance and energy costs are lower.

Consider multiple uses of such spaces. Often basketball courts may be used for other sports such as volleyball and even social functions. Provide a lighting system that can provide the highest light level that may be required and then utilize controls to address various uses of the space. In the case of a fluorescent system, lamps within luminaires can be switched separately. For metal halide designs, consider circuiting luminaires alternately so that a partial quantity can be switched off. Refer to UFC 4-740-02N for additional requirements.

RECREATIONAL FACILITIES

Locker Rooms



Pendant mounted direct / indirect luminaire .

EQUIPMENT RECOMMENDATIONS:

	LUMINAIRE	LAMP	CONTROLS
A	<i>Pendant mounted linear fluorescent indirect / direct luminaire</i>	<i>4' linear fluorescent T8 lamps, 3500K color temperature, 75 CRI+</i>	<i>Control with occupancy sensors.</i>
A ALT	<i>Surface mounted linear fluorescent strip on top of lockers</i>	<i>4' linear fluorescent T8 lamps, 3500K color temperature, 75 CRI+</i>	<i>Control with occupancy sensors.</i>

CRITICAL DESIGN ISSUES:

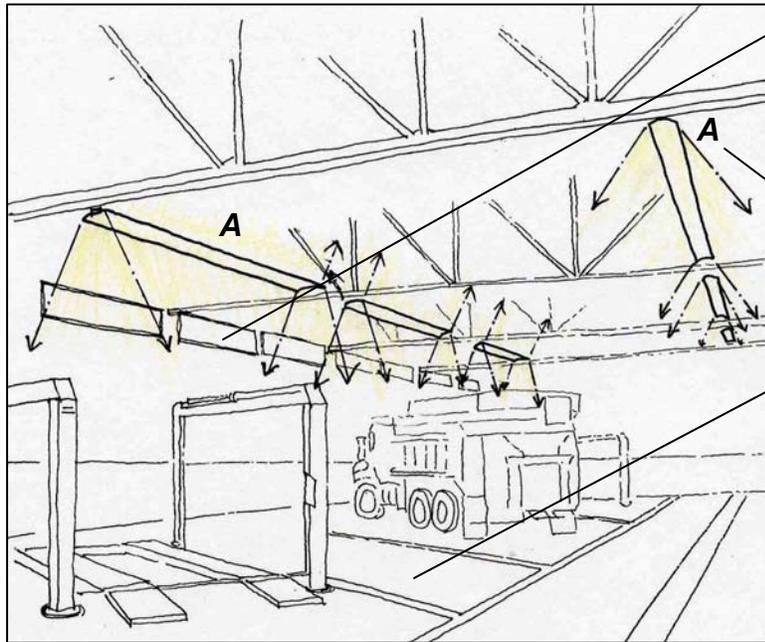
- Color Appearance (and Color Contrast): In order to identify colors of clothes it is very important to provide fluorescent lighting with good color-rendering properties.
- Shadows: By providing an indirect component of the lighting system, it will put some light into the lockers even when someone is standing in front of it. If a downlight only system is used light may be blocked by the user and the locker interior will be dark.
- Target Horizontal Illuminance ($\pm 10\%$): IESNA recommends 100 lux (10 fc). Refer to UFC 4-740-02N for additional requirements.

DISCUSSION:

The ambient lighting for a locker room is low with little task lighting required, with the exception of a higher light level at sinks. In addition to the scheme presented here, linear fluorescent strips can also be mounted on top of the banks of lockers, uplighting the ceiling in a completely indirect lighting system.

MAINTENANCE FACILITIES

Vehicle Storage / Repair Areas



Introduce and control daylight. Integrate with electric lighting controls to reduce energy use.

Pendant mounted direct / indirect luminaire reduces direct glare.

Luminaire spacing provides uniform illuminance on task plane.

EQUIPMENT RECOMMENDATIONS:

	LUMINAIRE	LAMP	CONTROLS
A	<i>Pendant mounted linear fluorescent direct / indirect luminaire.</i>	<i>4' linear fluorescent T8 or T5HO lamps, 4100K color temperature, 75 CRI+</i>	<i>Integrate controls with available daylight.</i>
A ALT	<i>Surface mounted low bay luminaire</i>	<i>Induction lamp</i>	<i>Control with occupancy and daylight sensors.</i>
B	<i>Moveable task lighting</i>	<i>Compact fluorescent lamps.</i>	<i>Manual on/off</i>

CRITICAL DESIGN ISSUES:

- **Direct Glare:** Direct glare is not only an annoyance when experienced for a short period of time, but can also cause fatigue when working for an extended period. Because the luminaires are located relatively high above the task plane, direct glare will most likely be avoided. Fluorescent lamps also distribute brightness over a large area, also reducing glare from the luminaire.
- **Flicker (and Strobe):** This strobe effect is critical when working with high-speed machinery. If the garage will be used as a shop with any kind of rotating tool, high quality electronic ballasts need to be specified to avoid a flicker effect.
- **Light Distribution on Surfaces:** With a small indirect component from the luminaires, the ceiling will have some surface brightness that reduces contrast and improves visual comfort in the space.

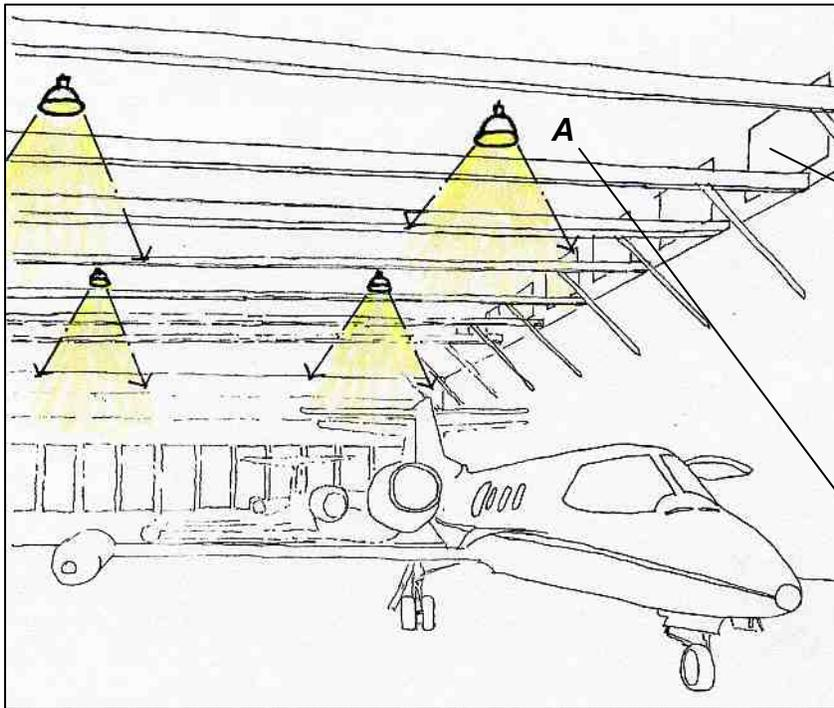
- Light Distribution on Task Plane (Uniformity): Design luminaire layout to uniformly distribute light over the work-plane to avoid dark areas in the space.
- Shadows: Select and locate luminaires to avoid shadows on the work-plane. Task lighting can also increase the illuminance on the task as well as eliminate shadows.
- Source / Task Eye Geometry: Locate luminaires relative to tasks to avoid direct glare and prevent shadowing.
- Illuminance on Task Plane: Maintenance on vehicles often requires high lighting levels. This may be accomplished with high vertical south and north oriented clerestories. Electric lighting, such as linear high output fluorescents can provide direct and indirect lighting for the most uniform application when daylight levels are insufficient. Portable task lighting can increase illuminance to the required level at the particular task.
- Target Horizontal Illuminance ($\pm 10\%$): 500 lux (50 fc)

DISCUSSION:

Although light level is important to achieve in a vehicle repair area, uniformity and the prevention of glare and shadowing also must be achieved to provide a comfortable and functional workspace. Portable task lighting allows for higher light levels at the task location without increasing the overall ambient level throughout the space.

MAINTENANCE FACILITIES

Aircraft Hangars and Shelters



Introduce and control daylight. Integrate with electric lighting system to reduce energy use.

Metal halide luminaires with a small uplight component help to reduce contrast between ceiling and luminaire.

EQUIPMENT RECOMMENDATIONS:

	LUMINAIRE	LAMP	CONTROLS
A	<i>Pendant mounted metal halide luminaire.</i>	<i>Metal halide, HPS, or induction lamp</i>	<i>Integrate controls with available daylight.</i>
A ALT	<i>Pendant mounted linear fluorescent luminaire with small uplight component.</i>	<i>4' linear fluorescent T8 or T5HO lamps, 4100K color temperature, 75 CRI+</i>	<i>Control with occupancy and daylight sensors.</i>

CRITICAL DESIGN ISSUES:

- **Direct Glare:** Because the luminaires are located relatively high above the task plane, direct glare will most likely be avoided. Fluorescent lamps distribute brightness over a large area (larger than metal halide lamps), further reducing glare from the luminaire.
- **Flicker (and Strobe):** This strobe effect is critical when working with high-speed machinery. If the hangar will be used as a shop with any kind of rotating tool, high quality electronic ballasts need to be specified to avoid a stroboscopic effect.
- **Light Distribution on Surfaces:** With a small indirect component from the luminaires, the ceiling above will have some surface brightness, reducing contrast between ceiling and luminaire, improving visual comfort in the space.

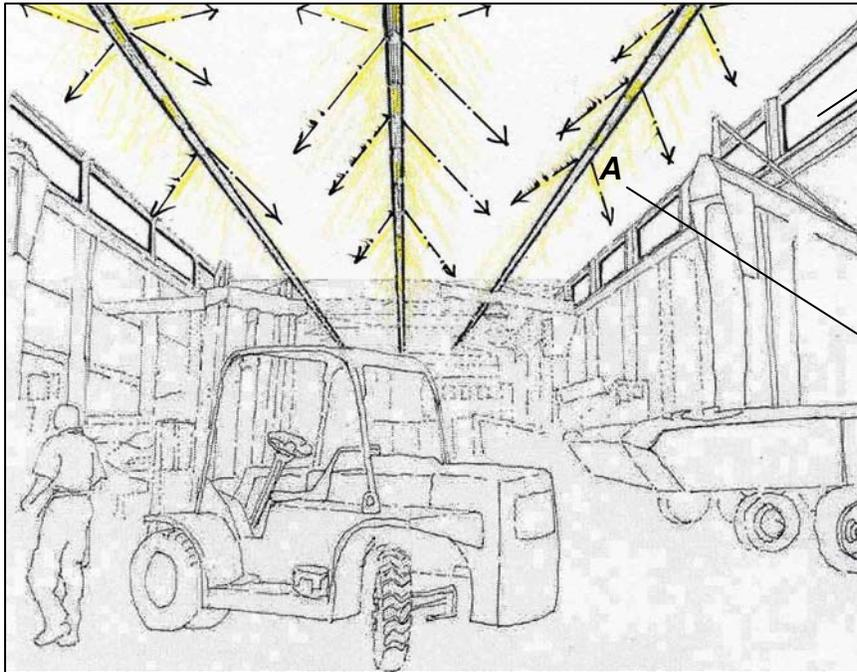
- Light Distribution on Task Plane (Uniformity): Design luminaire layout to uniformly distribute light over the work-plane to avoid dark areas in the space.
- Shadows: Select and locate luminaires to avoid shadows on the repair areas of the hangar. Portable task lighting can also increase the illuminance on the task as well eliminate shadows.
- Target Horizontal Illuminance ($\pm 10\%$): 500 lux (50 fc)

DISCUSSION:

By introducing daylight high in the space, much of electric lighting can be turned off during the day. Although light level is important to achieve in a hangar, uniformity and the prevention of glare and shadowing also must be achieved to provide a comfortable and functional workspace. Portable task lighting allows for higher light levels at the task location without increasing the overall ambient level.

MAINTENANCE FACILITIES

Motorpools



Introduce daylight on north and south facades and control glare.

Surface or pendant mounted fluorescent direct / indirect industrial strips.

EQUIPMENT RECOMMENDATIONS:

	LUMINAIRE	LAMP	CONTROLS
A	Surface mounted fluorescent industrial luminaire	4' linear fluorescent T5HO lamps, 4100K color temperature, 75 CRI+	Control with occupancy and daylight sensors.
A ALT	Surface mounted low bay luminaire	Induction lamp	Control with occupancy and daylight sensors.

CRITICAL DESIGN ISSUES:

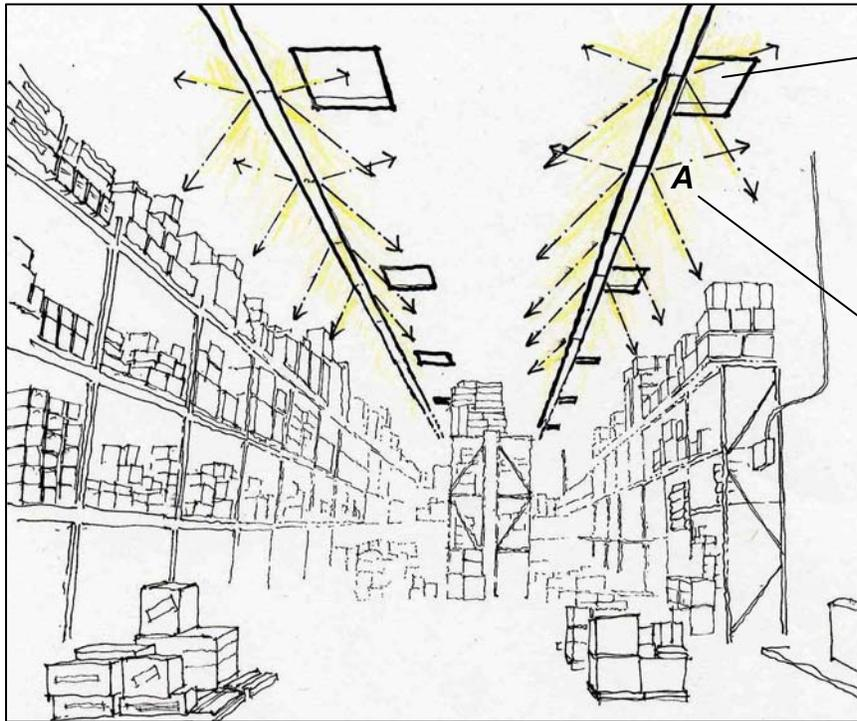
- Horizontal and vertical illuminance: Maintenance on vehicles may require high lighting levels. This may be accomplished with high vertical south and north facing clerestories. Electric lighting, such as linear fluorescent lamps can provide direct and indirect lighting for the most uniform application when daylight levels are insufficient.
- Source/Task Eye Geometry: When maintaining vehicles, it is very important to have the light coming from an angle that will not cause extraneous shadows. Linear sources such as clerestories and linear fluorescent lamps will minimize confusing shadows. Portable task lighting is encouraged to increase light levels at the location of a particular task.
- Color Appearance and Contrast: Maintaining vehicles demands excellent color-rendering and contrast recognition such as for metal-to-metal parts and components. The lighting system must provide good color rendering and enhance contrast.
- Target Horizontal Illuminance ($\pm 10\%$): 500 lux (50 fc)

DISCUSSION:

Just as important as the light level, the light distribution in motor pools should minimize shadows and illuminate uniformly over the task plane. Portable task lighting allows for higher light levels at the task location without increasing the overall ambient level. A combination of daylight and diffuse fluorescent lighting provides a high level of visibility. If daylight is plentiful, the electric lighting can be turned off or dimmed.

MAINTENANCE FACILITIES

Warehouses



Introduce daylight and control glare. Integrate with electric lighting system.

Surface or pendant mounted fluorescent direct / indirect industrial luminaires.

EQUIPMENT RECOMMENDATIONS:

	LUMINAIRE	LAMP	CONTROLS
A	Surface mounted fluorescent industrial luminaire with 5% - 10% uplight	4' linear fluorescent T8 or T5HO lamps, 4100K color temperature, 75 CRI+	Control with occupancy and daylight sensors.
A ALT	Surface mounted low bay luminaire	Induction lamp	Control with occupancy and daylight sensors.

CRITICAL DESIGN ISSUES:

- Horizontal and Vertical Illuminance: Toplighting is one strategy to introduce daylight and provide uniform light levels. Electric lighting, such as linear fluorescent lamps can provide direct and indirect lighting when daylight levels are insufficient.
- Source/Task Eye Geometry: Locate luminaires to minimize direct glare and to light shelves uniformly with minimal shadowing.
- Color Appearance and Contrast: In warehouses, individuals may need to locate and sort items. Provide lamp sources with a high color-rendering index to accurately portray colors and labels.
- Target Vertical Illuminance ($\pm 10\%$): Varies with use of space: 50 lux (5 fc) for inactive storage - 300 lux (30 fc) for active warehousing.

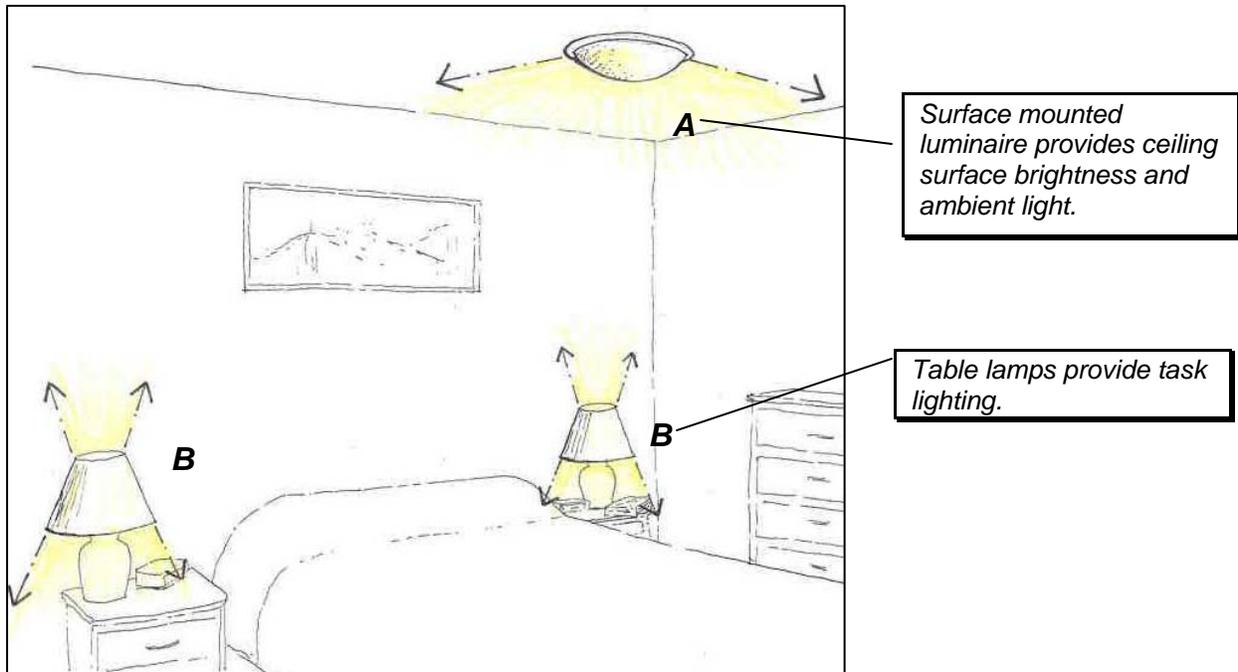
DISCUSSION:

The lighting for warehouses depends on the use of the facility. For infrequent use where the warehouse is used mostly for storage, the light level can be very low and preferably activated by a motion sensor. If sorting or inspection will be taking place or if people will be spending an extended period of time in the space, the light level should be higher.

It is also important to select a luminaire and develop a layout that provides vertical illuminance on the shelves. This facilitates identification of stored items.

If daylight can be introduced into the space, lighting control needs to integrate the electric lighting system with the available daylight, turning off unnecessary luminaires. Additionally, occupancy sensors not only save energy by turning on the luminaires only when needed, but also provide a convenience for anyone entering and leaving the space with hands full.

RESIDENTIAL HOUSING



EQUIPMENT RECOMMENDATIONS:

	LUMINAIRE	LAMP	CONTROLS
A	Surface mounted compact fluorescent luminaire	Compact fluorescent lamps, 3000K color temperature, 80 CRI+	Manual on/off.
A ALT	Wall mounted compact fluorescent sconce	Compact fluorescent lamps, 3000K color temperature, 80 CRI+	Manual on/off.
B	Table lamp with compact fluorescent lamp	Compact fluorescent lamps, 3000K color temperature, 80 CRI+	Manual on/off.

CRITICAL DESIGN ISSUES:

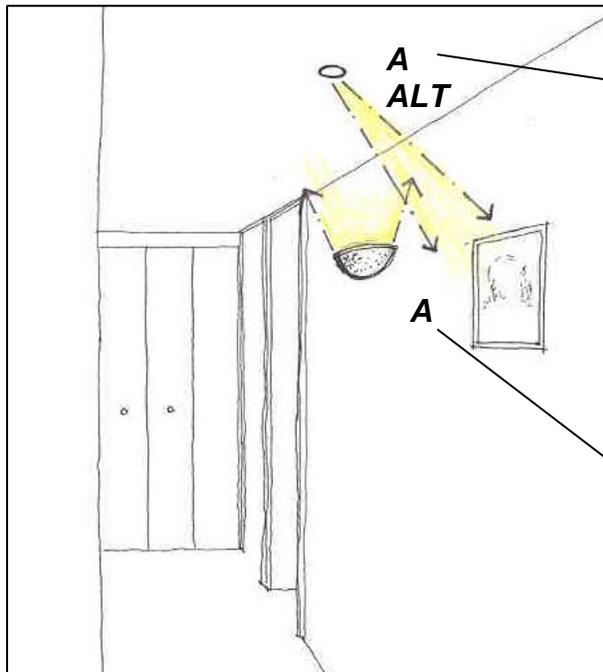
- **Direct Glare:** Locate and aim sources to avoid direct glare. This is especially important regarding lighting located above the bed to light artwork. Luminaires in this position may cause direct glare for a person reading bed.
- **Reflected Glare:** For a person reading in bed, locate task lighting to avoid reflected glare and veiling reflections on reading material.
- **Horizontal and Vertical Illuminance (for reading):** Task lighting needs to provide adequate illuminance on reading material. The light level required for reading should not be achieved with the ambient lighting alone. Task lighting (in the form of bedside lamps) allows flexibility and greater control over the lighting energy use.
- **Target Horizontal Illuminance ($\pm 10\%$):** 50 lux (5 fc) with higher light levels provided by table lamps for reading tasks.

DISCUSSION:

Compact fluorescent lighting is now available in residential luminaires such as table lamps, wall sconces, and overhead lighting. Dimming is available with dimmable ballasts. Also, the 3000K-lamp color closely resembles that of an incandescent lamp.

RESIDENTIAL HOUSING

Hallways



Recessed adjustable accent light highlights artwork.

Wall mounted sconce provides surface brightness and ambient light.

EQUIPMENT RECOMMENDATIONS:

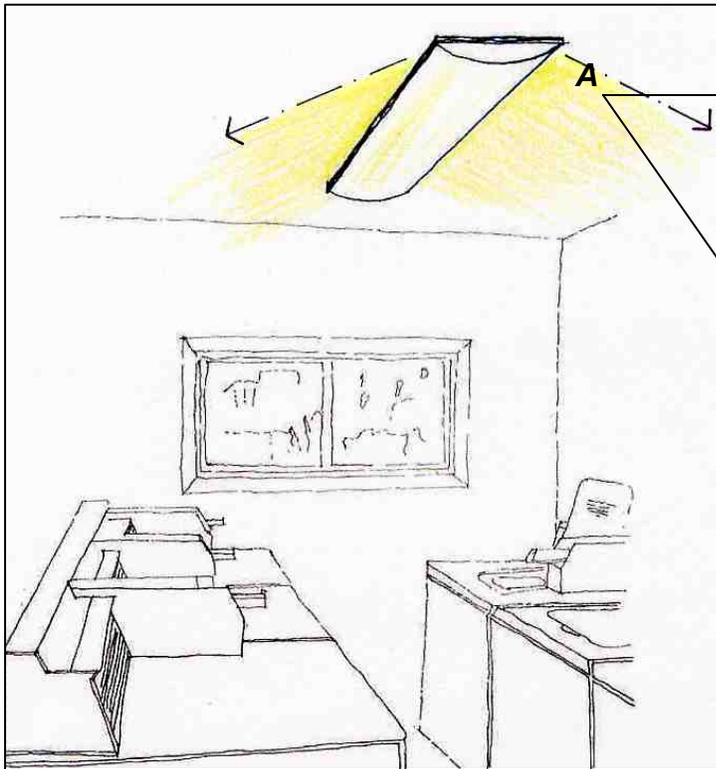
	LUMINAIRE	LAMP	CONTROLS
A	<i>Wall mounted compact fluorescent sconce</i>	<i>Compact fluorescent lamps, 3000K color temperature, 80 CRI+</i>	<i>Manual on/off with multi-location control. Consider the use of occupancy sensors and dimming.</i>
A ALT	<i>Recessed or surface mounted accent light</i>	<i>Controlled beam, tungsten halogen lamp</i>	<i>Manual on/off with multi-location control. Consider the use of occupancy sensors and dimming.</i>
A ALT	<i>Surface mounted compact fluorescent luminaire</i>	<i>Compact fluorescent lamps, 3000K color temperature, 80 CRI+</i>	<i>Manual on/off with multi-location control. Consider the use of occupancy sensors and dimming.</i>

CRITICAL DESIGN ISSUES:

- **Direct Glare:** Always avoid direct glare, even in areas that are occupied briefly. In the case of hallways, low brightness luminaires create a soft ambient lighting environment for wayfinding without the annoyance of direct glare.
- **Horizontal and Vertical Illuminance:** Adequate light levels need to be provided for safety in hallways. With low brightness luminaires and uniform surface brightness in the space, these light levels can be low relative to adjacent spaces.
- **Target Horizontal Illuminance ($\pm 10\%$):** 30 lux (3 fc)

RESIDENTIAL HOUSING

Laundry Rooms



Surface mounted fluorescent luminaire adds brightness to the ceiling.

Fluorescent lamps with good color-rendering characteristics provide good color appearance and contrast in the space.

EQUIPMENT RECOMMENDATIONS:

	LUMINAIRE	LAMP	CONTROLS
A	Surface mounted linear fluorescent luminaire	4' linear fluorescent T8 lamps, 3000K color temperature, 80 CRI+	Control with occupancy sensors.

CRITICAL DESIGN ISSUES:

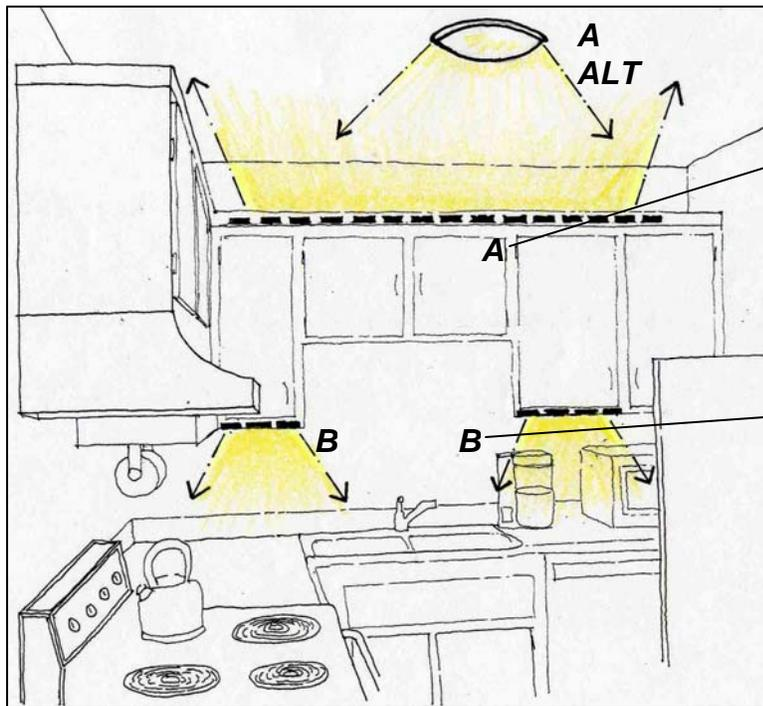
- Color Appearance and Contrast: In order to identify clothes colors (such as matching blue or brown socks), it is very important to provide fluorescent lighting with good color-rendering properties. In addition, the contrast on the task should be minimal. Locate the lighting so that body shadows do not interfere with seeing the task.
- Target Horizontal Illuminance ($\pm 10\%$): 300 lux (30 fc)

DISCUSSION:

Laundry rooms provide a good opportunity for the use of occupancy sensors. In this type of space, people usually leave with their hands full so automatic control of the lights is a convenience as well as an energy savings. Because the room is used infrequently, lights left on will be on for a long time.

RESIDENTIAL HOUSING

Kitchens



Concealed fluorescent strips uplight the ceiling. (Ceiling brightness could also be achieved with a surface mounted luminaire.)

Undercabinet tasklights illuminate countertop.

Introduce daylight with the use of windows, skylights, or light tubes. Provide controls to turn off lighting that is not required.

EQUIPMENT RECOMMENDATIONS:

	LUMINAIRE	LAMP	CONTROLS
A	Surface mounted linear fluorescent strip	2', 3', and 4' linear fluorescent T8 lamps, 3000K color temperature, 80 CRI+	Control ambient and task lighting separately.
A ALT	Ceiling mounted linear or compact fluorescent luminaire	Compact or linear fluorescent lamps, 3000K color temperature, 80 CRI+	Control ambient and task lighting separately.
B	Surface mounted linear fluorescent undercabinet tasklight	2', 3', and 4' linear fluorescent T8 lamps, 3000K color temperature, 80 CRI+	Control ambient and task lighting separately.

CRITICAL DESIGN ISSUES:

- **Color Appearance and Contrast:** In kitchens, the color appearance of food is very important. Kitchens are also the gathering places for friends and family, so good color appearance and realistic contrast should be achieved.
- **Direct Glare:** During food preparation or conversation, direct glare can become an irritant. Using indirect ambient lighting and under-counter task lighting can greatly reduce the direct glare.
- **Reflected Glare:** If lighting is improperly placed directly in front of the cook, reading recipes and preparing food can be a challenge. Minimize reflected glare with proper lighting equipment locations.

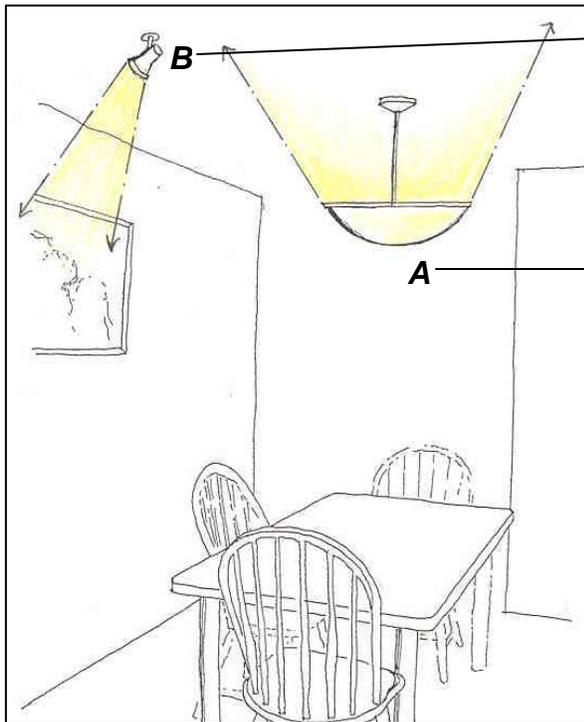
- Source/Task Geometry: Overhead ambient lighting and under-counter task lighting will minimize confusing shadows. Locate luminaires so that shadows are minimized and the light is where it is needed.
- Horizontal and Vertical Illuminance: In order to prepare food, read recipes and communicate with friends and family, adequate lighting levels need to be provided. Dimming the lighting can not only save energy, but give flexibility to the occupant.
- Target Horizontal Illuminance ($\pm 10\%$): 300 lux (30 fc)

DISCUSSION:

Traditionally, kitchen lighting has been accomplished with a single overhead luminaire located in the center of the kitchen. With this arrangement, preparing food at the counter is a challenge, since the body shadows the work area. Ideally, locate luminaires above the cabinets so that the kitchen is filled with indirect ambient light. Then, locate under-cabinet luminaires for localized task lighting. Direct, recessed lighting is appropriate over the sink area or other areas without overhead cabinets.

RESIDENTIAL HOUSING

Dining Room



Adjustable accent light highlights artwork.

Pendant mounted decorative luminaire lights ceiling and provides ambient lighting.

Introduce daylight with the use of windows or skylights.

EQUIPMENT RECOMMENDATIONS:

	LUMINAIRE	LAMP	CONTROLS
A	<i>Pendant mounted compact fluorescent luminaire</i>	<i>Compact fluorescent lamps, 3000K color temperature, 80 CRI+</i>	<i>Control ambient and accent lighting separately. Provide dimming.</i>
A ALT	<i>Ceiling mounted compact fluorescent luminaire</i>	<i>Compact fluorescent lamps, 3000K color temperature, 80 CRI+</i>	<i>Control ambient and accent lighting separately. Provide dimming.</i>
B	<i>Recessed or monopoint mounted adjustable accent light.</i>	<i>Tungsten halogen directional lamp</i>	<i>Control ambient and accent lighting separately. Consider dimming to extend lamp life.</i>

CRITICAL DESIGN ISSUES:

- **Color Appearance and Contrast:** In dining rooms, the color appearance of food is very important. Dining rooms are also the gathering places for friends and family, so good color appearance and realistic contrast should be achieved.
- **Direct Glare:** Direct glare can become a distraction during dinner and should be avoided by providing appropriate low glare sources for ambient lighting and by aiming accent lighting away from those seated at the table.

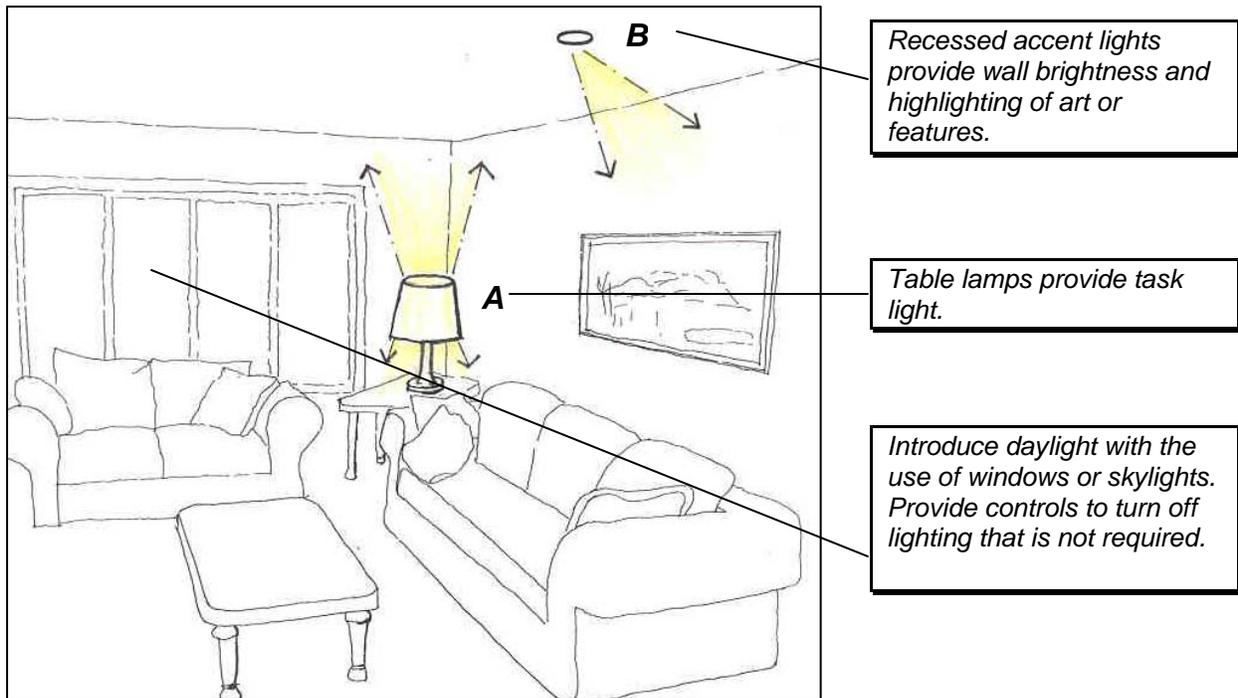
- Modeling of Faces and Objects: Low glare light from multiple sources provides adequate shadowing, depth perception, and modeling of any object in the room, including people.
- Horizontal Illuminance: Because dining tables may also be used as a desktop, adequate light levels must be maintained on the work plane. This amount of light should not be the default ambient light level, but should be controlled lighting that is only provided when necessary.
- Target Horizontal Illuminance ($\pm 10\%$): 50 lux (5 fc)

DISCUSSION:

Like living rooms, dining rooms are often used for variety of tasks. A dining room table may serve as a game table or desk as well as a dinner table. The lighting needs to provide a range of light levels to accommodate this range of use. Compact fluorescent dimming is available with dimming ballasts for many decorative luminaires.

RESIDENTIAL HOUSING

Living Rooms



EQUIPMENT RECOMMENDATIONS:

	LUMINAIRE	LAMP	CONTROLS
A	Table lamp	Compact fluorescent lamps, 3000K color temperature, 80 CRI+	Manual on/off.
A ALT	Floor lamp or torchiere	Compact fluorescent lamps, 3000K color temperature, 80 CRI+	Manual on/off.
A ALT	Wall mounted uplight	Compact fluorescent lamps, 3000K color temperature, 80 CRI+	Include the use of dimmers.
B	Recessed compact fluorescent wall washer or adjustable accent light	Compact fluorescent lamps, 3000K color temperature, 80 CRI+ or tungsten halogen directional lamp	Include the use of dimmers. Control ambient and accent lighting separately.

CRITICAL DESIGN ISSUES:

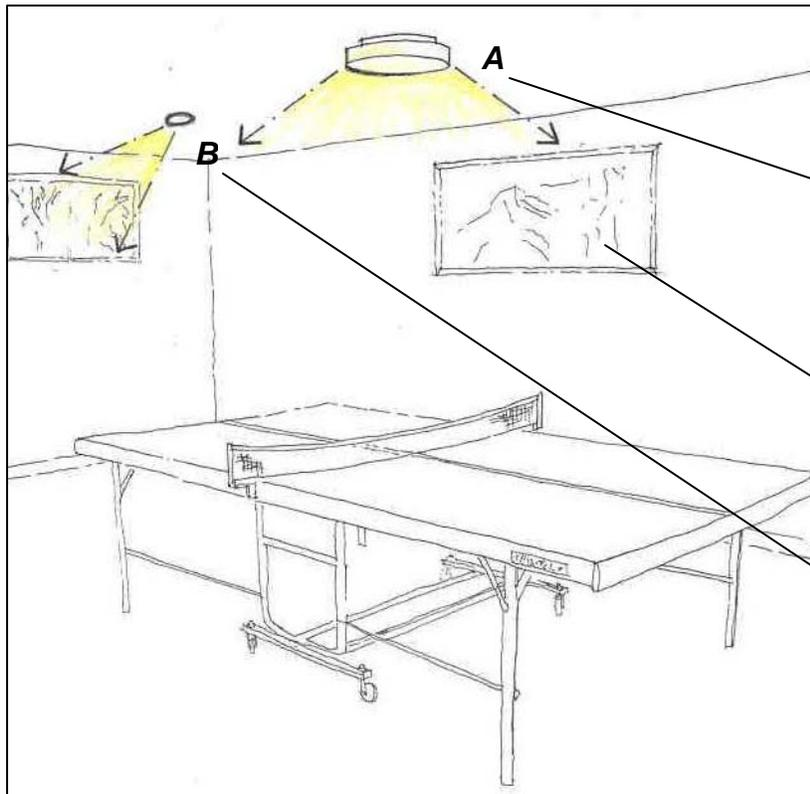
- **Direct Glare:** Light sources should not cause direct glare for a group of people visiting in a living room, or for a single person reading. Indirect, concealed sources provide for comfortable ambient light while eliminating direct glare.
- **Reflected Glare:** For a person reading, locate task lighting to avoid reflected glare on reading material.
- **Target Horizontal Illuminance ($\pm 10\%$):** 30 lux (3 fc)

DISCUSSION:

Living rooms often host a variety of activities. For this reason, controlling the lighting separately and with dimmers, not only saves energy but also allows occupants to adapt the lighting for the current use of the space. This may include casual or formal gatherings, or use by one person. Compact fluorescent luminaires are available with dimmable ballasts. Tungsten halogen floor torchieres, while popular in such spaces, represent an enormous waste of energy and a significant fire danger. Far more efficient compact fluorescent torchieres are becoming increasingly available.

RESIDENTIAL HOUSING

Rec Rooms



Surface mounted luminaire lights activities and provides ceiling brightness.

Introduce daylight with the use of windows, skylights, or light tubes. Provide controls to turn off lighting that is not required.

Recessed adjustable accent light highlights artwork.

EQUIPMENT RECOMMENDATIONS:

	LUMINAIRE	LAMP	CONTROLS
A	<i>Ceiling mounted compact fluorescent luminaire</i>	<i>Compact fluorescent lamps, 3000K color temperature, 80 CRI+</i>	<i>Control ambient and task lighting separately. Consider the use of occupancy sensors.</i>
B	<i>Recessed compact fluorescent wall washer or adjustable accent light</i>	<i>Compact fluorescent lamps, 3000K color temperature, 80 CRI+ or tungsten halogen directional lamp</i>	<i>Include the use of dimmers. Control ambient and accent lighting separately.</i>

CRITICAL DESIGN ISSUES:

- **Direct Glare:** Locate and aim sources to avoid direct glare. This is especially important where luminaires are lighting a game table.
- **Reflected Glare:** position luminaires to avoid reflected glare in any specular surface, especially a TV screen. This type of glare can also occur with glossy ready materials such as magazines.
- **Horizontal Illuminance (for reading):** Task lighting needs to provide adequate illuminance on reading material. The light level required for reading should not be achieved with the ambient lighting alone. Task

lighting (such as table lamps or drafting lamps) allows flexibility and greater control over the lighting and energy use.

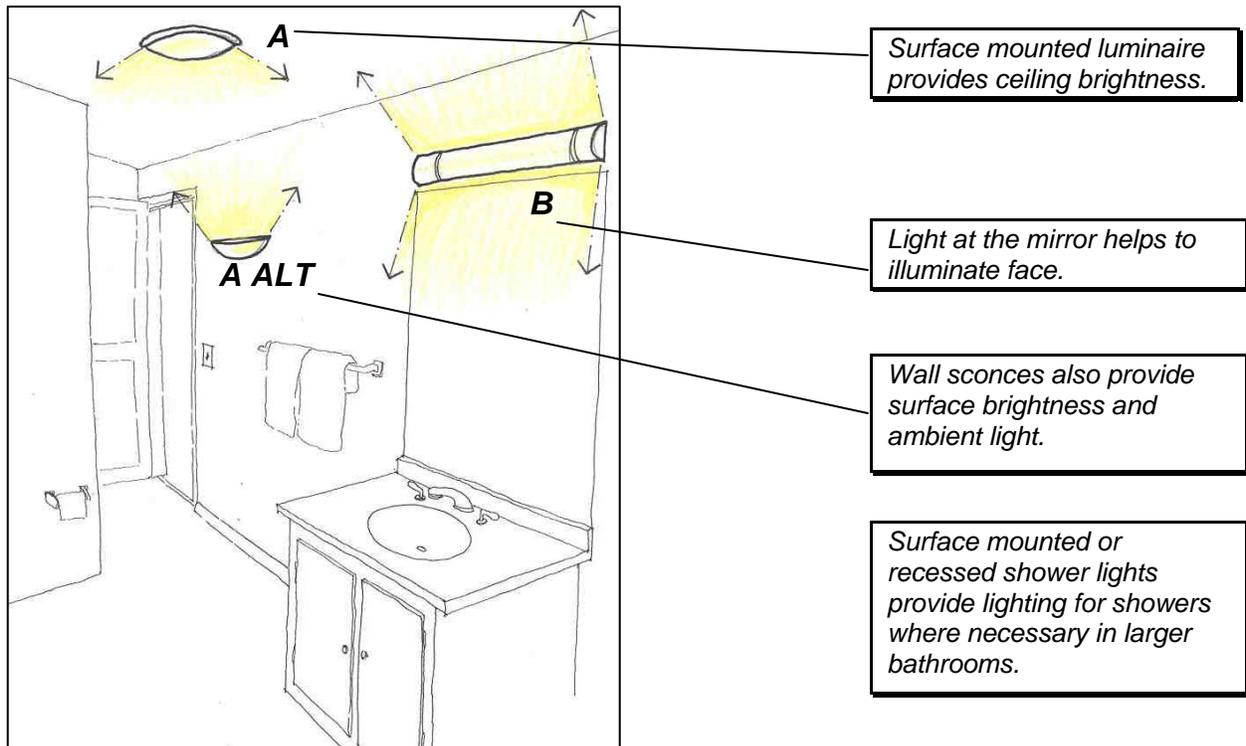
- Target Horizontal Illuminance ($\pm 10\%$): 300 lux (30 fc)

DISCUSSION:

Recreation rooms may host a variety of activities. Because of this, some flexibility and control will allow the lighting to adapt to the specific use. Provide adequate light levels for reading and games. However, glare must be avoided, especially for such games as ping-pong or pool. Consider the use of occupancy sensors for rec rooms to turn lights off when unoccupied.

RESIDENTIAL HOUSING

Bathrooms



EQUIPMENT RECOMMENDATIONS:

	LUMINAIRE	LAMP	CONTROLS
A	Surface mounted compact fluorescent luminaire.	Compact fluorescent lamps, 3000K color temperature, 80 CRI+	Control ambient lighting separately from task (vanity) lighting
A ALT	Wall mounted compact fluorescent sconce	Compact fluorescent lamps, 3000K color temperature, 80 CRI+	
B	Wall mounted linear vanity light.	4' linear fluorescent T8 lamps, 3000K color temperature, 80 CRI+	
C	Surface mounted or recessed compact fluorescent shower light.	Compact fluorescent lamps, 3000K color temperature, 80 CRI+	Control shower luminaire separately.

CRITICAL DESIGN ISSUES:

- Color Appearance and Contrast: For make-up application and grooming, the color temperature and rendering characteristics of the lamps should be as high as possible. These will render color accurately and as well as provide adequate color contrast.
- Luminances of Room Surfaces: Illuminate room surfaces to light people softly and eliminate sharp contrasts.
- Modeling of Faces or Objects: Light sources placed strategically eliminate harsh shadows on an occupant's face. For example, downlights in a bathroom will cause these shadows and should be avoided while a ceiling

mounted luminaire or wall sconce with low brightness will illuminate faces softly.

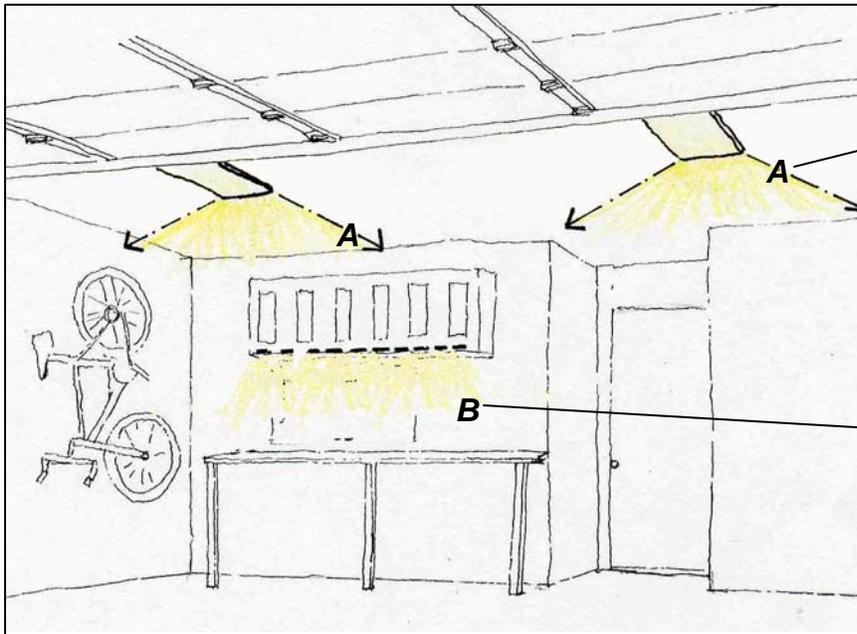
- Direct Glare: Direct glare in a bathroom will become an irritant while trying to shave or apply make-up. Avoid this by keeping the room surfaces bright and using low glare luminaires.
- Reflected Glare: With the use of adjustable mirrors, bathroom spaces should be designed with reflected glare in mind. Low glare luminaires will eliminate this as well as direct glare.
- Source / Task Eye Geometry: Locate light sources appropriately to avoid shadows on someone's face. This location should also minimize shadows throughout the space.
- Horizontal and Vertical Illuminance: Appropriately located task lighting provides higher illuminance levels at the point of the task. For example, at the mirror, a vanity light provides the necessary light levels for make-up application.
- Target Horizontal Illuminance ($\pm 10\%$): 300 lux (30 fc)

DISCUSSION:

Bathroom lighting is often achieved with incandescent "globe" vanity lights. While inefficient, these point sources do provide light from multiple directions on peoples' faces. A more efficient solution uses linear fluorescent vanity luminaires or a built-in valence, providing up/down light with a fluorescent lamp. In combination with other luminaires that light the room surfaces, the same soft lighting can be provided.

RESIDENTIAL HOUSING

Garages



Lensed luminaires provide high ambient light levels while minimizing direct glare. Luminaires are located so that garage door does not block light.

Additional task lighting under cabinets lights workbench.

EQUIPMENT RECOMMENDATIONS:

	LUMINAIRE	LAMP	CONTROLS
A	Surface mounted linear fluorescent luminaire	4' linear fluorescent T8 lamps, 3000K color temperature, 80 CRI+	Control with occupancy sensors.
B	Surface mounted linear fluorescent tasklight	4' linear fluorescent T8 lamps, 3000K color temperature, 80 CRI+	Manual on/off.

CRITICAL DESIGN ISSUES:

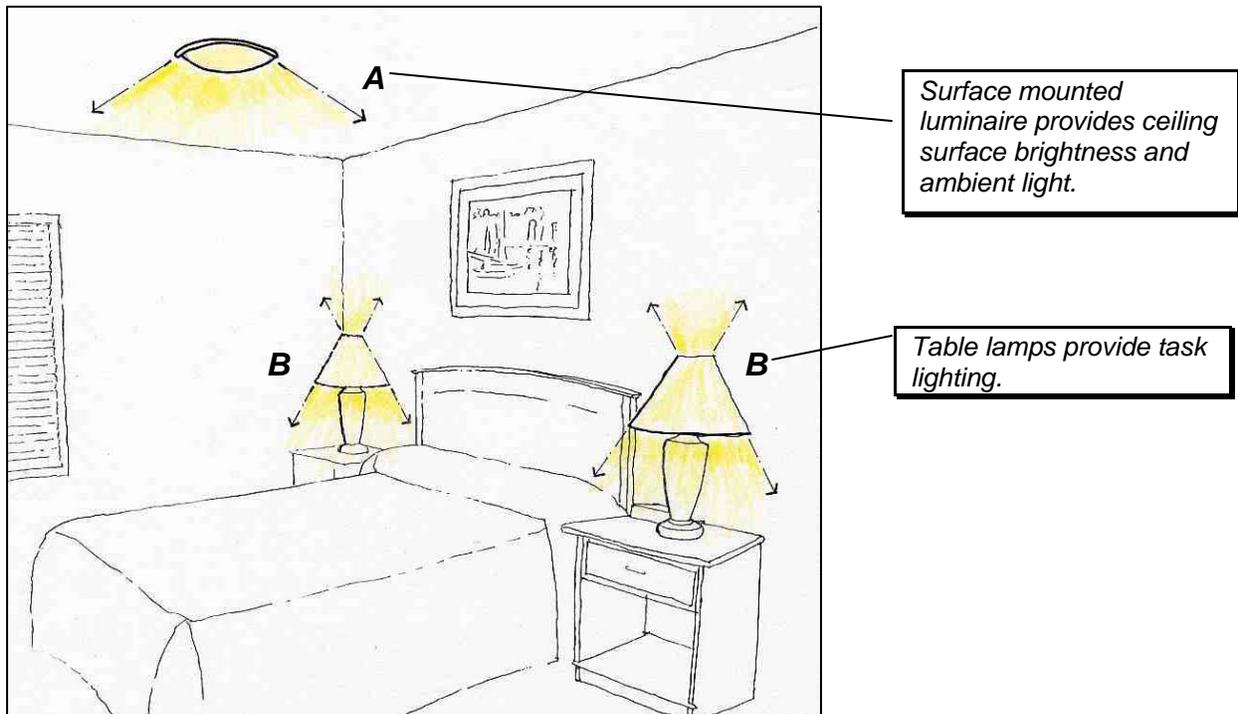
- **Direct Glare:** Direct glare is not only an annoyance, but can cause fatigue when working for an extended period. In a garage, minimize luminaire brightness with a lens.
- **Flicker (and Strobe):** This strobe effect is critical when working with high-speed machinery. If the garage will be used as a shop with any kind of rotating tool, specify quality high frequency electronic ballasts to avoid a flicker effect.
- **Source / Task Eye Geometry:** Locate ambient light sources and task lighting to avoid the shadowing of a workbench or tool area.
- **Horizontal and Vertical Illuminance:** Task lighting needs to adequately light small tasks that might take place at a workbench. Additionally, provide outlets for portable task lighting that might be used while working on a vehicle.
- **Target Horizontal Illuminance ($\pm 10\%$):** 200 lux (20 fc)

DISCUSSION:

Garages used only for car storage require very little ambient light. However, if the garage will be used as a shop, ambient levels can be increased slightly and task lighting should definitely be added to increase illuminance at the task.

HOUSING

Bachelors Quarters (Barracks)



EQUIPMENT RECOMMENDATIONS:

	LUMINAIRE	LAMP	CONTROLS
A	Surface mounted compact fluorescent luminaire	Compact fluorescent lamps, 3000K color temperature, 80 CRI+	Manual on/off.
A ALT	Wall mounted compact fluorescent sconce	Compact fluorescent lamps, 3000K color temperature, 80 CRI+	Manual on/off.
B	Table lamp with compact fluorescent lamp	Compact fluorescent lamps, 3000K color temperature, 80 CRI+	Manual on/off.

CRITICAL DESIGN ISSUES:

- **Direct Glare:** Locate and aim sources to avoid direct glare. This is especially important regarding lighting located above the bed to light artwork. Luminaires in this position may cause direct glare for a person reading bed.
- **Reflected Glare:** For a person reading in bed, locate task lighting to avoid reflected glare and veiling reflections on reading material.
- **Horizontal and Vertical Illuminance (for reading):** Task lighting needs to provide adequate illuminance on reading material. The light level required for reading should not be achieved with the ambient lighting alone. Task lighting (in the form of bedside lamps) allows flexibility and greater control over the lighting energy use. Use task lighting for desks.

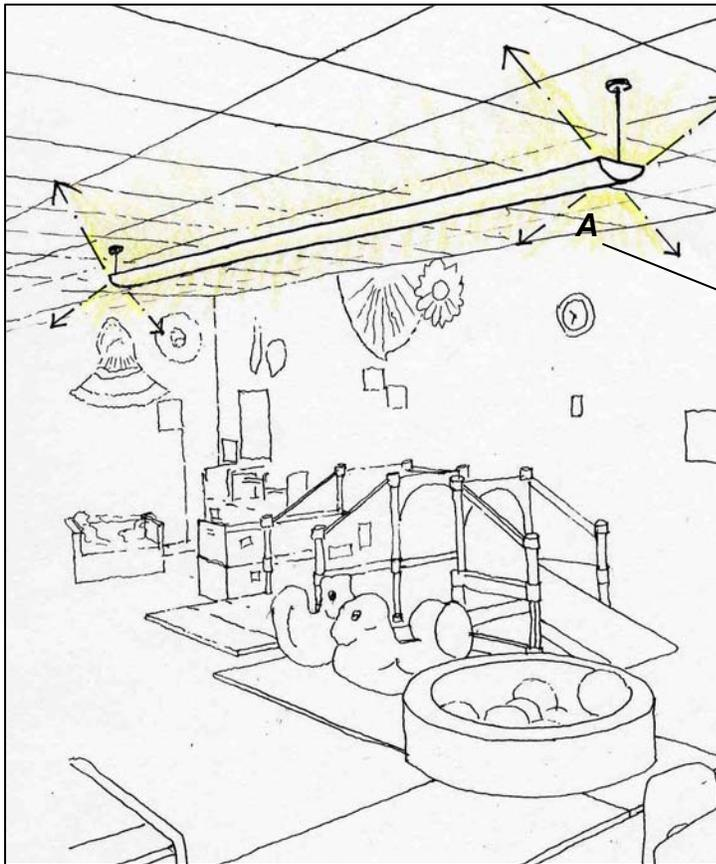
- Target Horizontal Illuminance ($\pm 10\%$): 50 lux (5 fc) with higher light levels provided by table lamps for reading tasks.

DISCUSSION:

Compact fluorescent lighting is now available in residential luminaires such as table lamps, wall sconces, and overhead lighting. Dimming is available with dimmable ballasts. Also, the 3000K-lamp color closely resembles that of an incandescent lamp. Provide task lighting at tables or desks in the room. (See UFC 4-721-10 or UFC 4-721-11.1.)

CHILDCARE FACILITIES

Daycare Indoor Play Areas



Introduce and control daylight. Daylighting strategies should also provide views to the outdoors.

Pendant mounted indirect / direct linear fluorescent luminaire.

EQUIPMENT RECOMMENDATIONS:

	LUMINAIRE	LAMP	CONTROLS
A	<i>Pendant mounted indirect / direct linear fluorescent luminaire.</i>	<i>4' linear fluorescent lamps, 3000K color temperature, 80 CRI+</i>	<i>Manual on/off and dimming. Also consider additional control with occupancy sensors.</i>
A ALT	<i>Surface mounted compact fluorescent luminaire.</i>	<i>Compact fluorescent lamps, 3000K color temperature, 80 CRI+</i>	<i>Manual on/off and dimming. Also consider additional control with occupancy sensors.</i>

CRITICAL DESIGN ISSUES:

- **Direct Glare:** Children and supervisors spend a significant amount of time in these play areas, so avoid direct glare.
- **Reflected Glare:** Select and locate luminaires to avoid veiling reflections on books or reading tasks on horizontal surfaces. The reflection of an unshielded lamp on reading material will obscure the task.
- **Horizontal and Vertical Illuminance (for reading):** The lighting system must provide adequate light levels for reading and writing. While this light level

may be achieved with the ambient lighting, table lamps or task lighting may also increase local reading lighting levels.

- Target Horizontal Illuminance ($\pm 10\%$): 300 lux (30 fc)

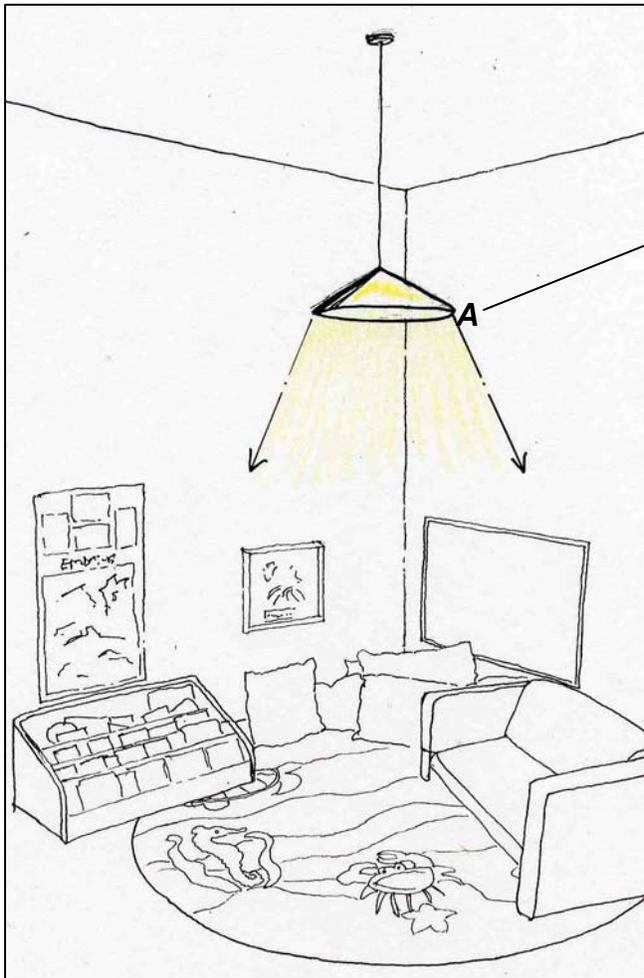
DISCUSSION:

Indoor play areas that rely heavily on daylight and provide a connection to the outdoors will create a much more pleasant environment. By providing the electric lighting controls, energy consumption can be reduced when it is not required. Dimming controls are also important to lower light levels during rest time.

Pendant mounted uplights provide indirect ambient light and a softly lit environment without shadows or direct glare. It is important to utilize luminaires that also have a small direct component to add some sparkle and visual interest. This type of light also integrates well with daylight, allowing for continuous surface brightness on the ceiling. As an alternate to pendant luminaires, surface mounted luminaires also provide some surface brightness.

CHILDCARE FACILITIES

Daycare Indoor Rest Areas



Pendant mounted luminaire lowers the "perceived ceiling" and helps to create a space within a larger space.

EQUIPMENT RECOMMENDATIONS:

	LUMINAIRE	LAMP	CONTROLS
A	<i>Pendant mounted compact fluorescent luminaire.</i>	<i>Compact fluorescent lamp, 3000K color temperature, 80 CRI+</i>	<i>Control separately from other area lighting. Provide with dimming controls.</i>
A ALT	<i>Surface mounted compact fluorescent luminaire.</i>	<i>Compact fluorescent lamp, 3000K color temperature, 80 CRI+</i>	<i>Control separately from other area lighting. Provide with dimming controls.</i>

CRITICAL DESIGN ISSUES:

- **Direct Glare:** Select luminaires to prevent direct glare. Luminaires may use lenses or louvers to shield any view of the lamp. Decorative, glowing luminaires should use low wattage lamps.
- **Reflected Glare:** Select and locate luminaires to prevent veiling reflections on reading material.

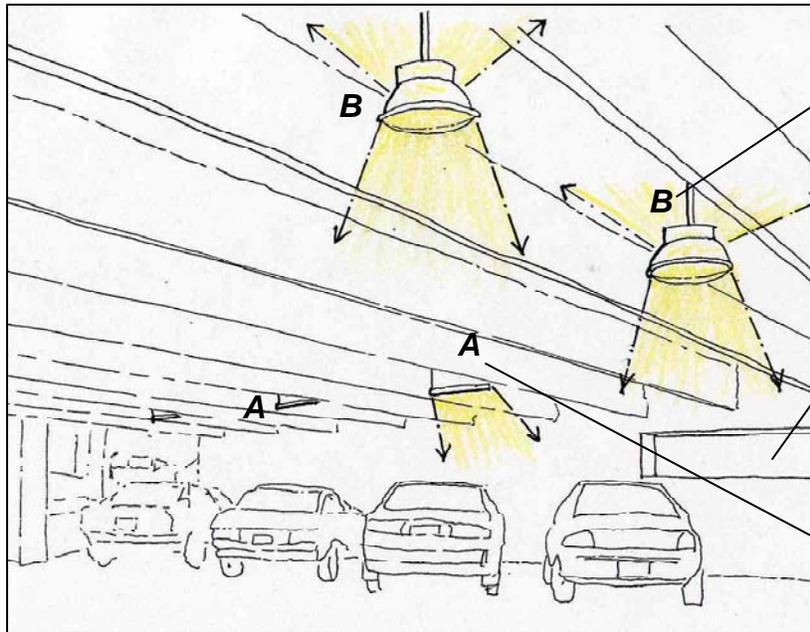
- Horizontal and Vertical Illuminance (for reading): While enough light must be provided for reading, the ambient light level can be very low. A softly lit area with a low light level will result in a more restful space.
- Target Horizontal Illuminance ($\pm 10\%$): 100-200 lux (10-20 fc)

DISCUSSION:

Indoor rest areas require a soft ambient light that prevents direct or reflected glare. A decorative, pendant visually separates this area from a larger space. Dimmable lighting will provide a wide range of lighting levels for various activities.

PARKING FACILITIES

Parking Structures



Low brightness, shielded luminaires prevent direct glare.

Introduce and control daylight and adjacent luminaires on perimeter bays.

Wallwashing improves surface brightness and contrast.

EQUIPMENT RECOMMENDATIONS:

	LUMINAIRE	LAMP	CONTROLS
A	<i>Surface mounted linear fluorescent wall washers</i>	<i>4' linear fluorescent T8 or T5HO lamps, 3500K color temperature, 75 CRI+</i>	<i>Control with occupancy and daylight sensors.</i>
B	<i>Pendant/Surface mounted parking garage luminaire</i>	<i>Induction lamp</i>	<i>Control with occupancy and daylight sensors.</i>
B ALT	<i>Pendant/Surface mounted parking garage luminaire</i>	<i>Metal halide</i>	<i>Manual on/off.</i>

CRITICAL DESIGN ISSUES:

- **Direct Glare:** While driving a vehicle in a parking structure, the glare from the luminaires cannot interfere with the motorist's visibility. All lighting must limit the direct glare into the driver's eyes.
- **Modeling of Faces and Objects:** Lighting needs to highlight pedestrians. This can be accomplished with low glare luminaires that are located in front of common pedestrian conflict zones such as crosswalks and circulation corridors.
- **Peripheral Detection:** Use white light sources to enhance peripheral detection.
- **Reflected Glare:** Locate luminaires over the vehicle parking areas to minimize the potential of reflected glare in the driveways.

- Shadows: Shadows need to be helpful, not confusing. This is especially important on stairs, where the shadows clearly indicate where the stair treads are located.
- Source / Task Eye Geometry: Motorists must be able to clearly see pedestrians and to navigate through the parking structure. The lighting should not present glare to inhibit these important tasks.
- Vertical Illuminance: Lighting the interior vertical walls of the parking structure gives guidance to circulation areas and the surrounds of the structure. Also, pedestrians and other vehicles have vertical surfaces that must be detected.
- Target Horizontal Illuminance ($\pm 10\%$): Varies depending on use and security requirements; 50 lux (5 fc)

DISCUSSION:

The most important areas to light in a parking structure are the interior walls, providing indirect light for guidance and for lighting the fronts of parked vehicles. Secondly, overhead lighting should be located over the parked vehicles. If the lighting is over the drive lanes, the luminaire brightness could inhibit the driver's ability to navigate and detect pedestrians. Parking garages need to be painted a high reflectance value in order to make the lighting most effective. Treat the top, open-air deck of the parking structure the same as parking lots.

Use daylight whenever possible, and turn off or dim lighting when daylight is adequate near the perimeter. In addition, provide more lighting at entrances during the day to help in the visual transition from daylight to a darker garage. At night, these daylight luminaires must be turned off.

CHAPTER 7

EXTERIOR APPLICATIONS

7-1 **INTRODUCTION.** This chapter identifies typical exterior facility applications and explains the critical design issues for each as outlined in the Quality of the Visual Environment chapter of the *Lighting Handbook*. Each application details a conceptual lighting design for a sample space with a sketch and equipment recommendation. This sample represents one solution that addresses the design issues and meets the appropriate criteria. It is not the only solution and alternate schemes will result in acceptable designs.

7-1.1 Exterior lighting sources. White light sources such as metal halide, induction, and fluorescent provide better visibility at low light levels than high-pressure sodium lamps. Refer to paragraph 2-5.2 for more details. Additionally, induction lamps have the added benefits of instant-on switching and long lifetimes. However, high-pressure sodium can be used to match existing equipment for ease of maintenance and visual continuity.

7-1.2 Exterior security lighting is an important issue for many facilities and not all of the specific criteria are addressed in this section. For additional information, refer to MIL-HDBK-1013/1A and UFC 4-011-02.

7-1.3 Coordinate the design and luminaire selection with the landscape designer. Such coordination should include the location of poles that may conflict with tree locations.

7-2 **CALCULATIONS OF LIGHTING FOR EXTERIOR AREAS.**

7-2.1 Criteria. Lighting for exterior areas is measured with a variety of parameters. Maximum, minimum, and average illuminance values are often listed as target criteria. Uniformity criteria may be described with multiple terms including maximum to minimum and maximum to average. Additionally, veiling luminance and small target visibility criteria can also be used to measure roadway lighting. The most appropriate criteria vary with the type of application. The following lists this UFC's interpretation of the IESNA criteria and how it is used in the applications shown in this chapter:

- Minimum illuminance: This provides the low end of the range of acceptable light levels. This is typically used in applications where lighting will be continuous or cover a large area such as roadways and parking lots.
- Maximum illuminance: This provides the high end of the range of acceptable light levels. This is typically used in applications where lighting will be continuous or cover large areas such as roadways and parking lots. It is also used to prevent overlighting of an area.

- Average illuminance: This criterion is typically used to give an approximate light level. Typically this is used for areas where the lighting may not be continuous and therefore give a better value than maximum and minimum.
- Maximum to minimum uniformity: This is often used in applications where lighting will be continuous or cover large areas such as roadways and parking lots. It is less useful to define lighting in areas such as entries where lighting may be designed to highlight a particular point. Table 7-1 lists recommended ratios for various applications.
- Average to minimum uniformity: This criteria is also used to ensure adequate uniformity. This is an easy value to calculate with typical lighting software, but more difficult to measure and verify in final installations. Table 7-1 lists recommended ratios for various applications.

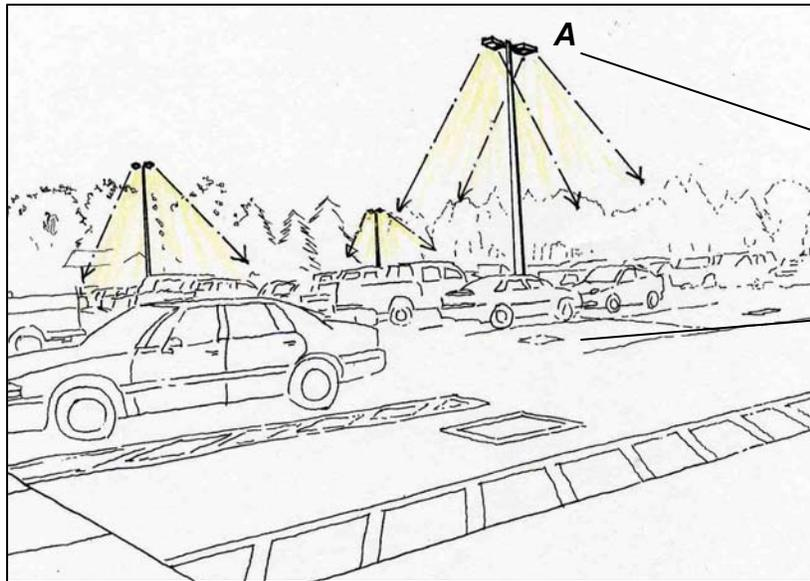
Table 7-1. Recommended Illuminance Uniformity Ratios for Exterior Applications.

Application	Average / Minimum Ratio	Maximum / Minimum Ratio
Expressways and Major Roadways	3 : 1	
Collector Roadways	4 : 1	
Local Roadways	6 : 1	
Parking Facilities (primarily day-use)		20 : 1
Parking Facilities (night-use)		15 : 1
Pedestrian Walkways and Bikeways	4 : 1	

7-2.2 Point Calculations for Flood and Spot Lighting. Point calculations are a calculation procedure that can be performed by hand or in simple, spreadsheet formulas. They determine the illumination at a point in either the horizontal or the vertical plane, and are reliable only for single luminaires. Manufacturers often provide photometric data in “iso-footcandle” form, which permits rapid assessment of the performance of a single luminaire.

7-2.3 Automated Calculations for Exteriors. Commercially available computer programs perform point-by-point calculations. These programs permit multiple luminaires and can take buildings and other obstacles into account. Most programs generate CAD-compatible site isolux plots and analytical statistics related to illuminance and uniformity. Luminance, veiling luminance, and small target visibility should also be calculated for roadway applications.

PARKING FACILITIES



Fully shielded or full cut-off luminaires control glare and reduce light pollution and trespass.

Spacing of luminaires provides uniform horizontal illuminance in parking areas.

EQUIPMENT RECOMMENDATIONS:

	LUMINAIRE	LAMP	CONTROLS
A	<i>Pole mounted metal halide, induction, or HPS luminaire.</i>	<i>Metal halide, induction, or high-pressure sodium lamp.</i>	<i>Control with photocell, timeclock, or motion sensor (only with induction lamp).</i>

CRITICAL DESIGN ISSUES:

- Direct Glare: Because the surroundings may be very dark at night, consider direct glare from luminaires and excessive contrast of surfaces. Luminaires should use shielded lamps and as low a wattage as possible.
- Light Pollution / Trespass: The use of fully shielded or IESNA full-cutoff luminaires eliminates direct light above the horizontal plane. Using cut-off optics and low wattage lamps can minimize light pollution. Shielded luminaires minimize the chance of light trespass on a neighboring property or building.
- Modeling of Faces or Objects: By providing light from multiple directions, objects and people are accurately rendered and modeled.
- Peripheral Detection: Our sense of security relies heavily on peripheral vision. Research shows that peripheral vision and detection are enhanced under white light. White light (as opposed to more orange light produced by high-pressure sodium) allows faster peripheral detection than the “fuzzy” high-pressure sodium light sources. Also, colors are rendered more accurately under white light.
- Reflected Glare: Wet surfaces often provide a surface that has the potential for reflected glare. Select and locate luminaires to minimize this as much as possible.

- Shadows: Locate and space poles so that the light from the luminaires minimizes shadows that could conceal potential hazards.
- Vertical Illuminance: Vertical illuminance lights individuals' faces as well as potential hazards.
- Target Horizontal Illuminance: Follow the Recommended Maintained Illuminance Values for Parking Lots outlined in IESNA RP-20-98. Nighttime use areas such as retail and libraries should use the higher "Enhanced Security" values. Facilities that are primarily daytime use only such as offices should use the "Basic" values. Average illuminance levels are typically 10 -20 lux (1-2 fc) although maintaining the minimum, maximum, and uniformity criteria is more important than meeting an average level.

DISCUSSION:

Parking lot lighting should provide uniform illuminance or luminance while avoiding direct glare. By utilizing fully shielded or full cut-off luminaires, the direct beam light that contributes to light pollution will be eliminated. Because poles are often located at the perimeter of lots and next to adjacent properties, light trespass must be carefully considered and prevented. Cut-off luminaires, house-side shields, and low wattage lamps all help to reduce the chance of light trespass.

RULES OF THUMB:

- Spacing to Mounting Height: When beginning a design, start with a 4:1 spacing to mounting height ratio and modify accordingly to meet critical design issues.
- Distribution: Use Type V distributions for luminaires within the parking areas. Use Type III and IV distributions for luminaires along the perimeters.

EXAMPLE ANALYSIS WITH LUMEN EFFECTIVENESS MULTIPLIERS:

This parking area example shows how lumen effectiveness multipliers may be used to compare high-pressure sodium and metal halide sources. A 200 x 600 ft parking lot was evaluated with the AGI lighting calculation program (Lighting Analysts, Inc.). The table on the following page outlines the results for two different light sources with the same pole layout, luminaire, and mounting height. The lamp wattages are the same (250 watt) for each case.

Determining Effective Values

- *Step #1: Calculate Luminance.* The first line for each case shows the calculated average, maximum, and minimum luminance. These are determined from a lighting calculation program such as AGI.
- *Step #2: Determine LEM Multipliers.* The luminance values were then applied to Table 2-1 or Figure 2-7, "Lumen Effectiveness Multipliers" shown in Chapter 2 "Lighting Design Considerations". By entering the first row of Table 2-1 with any luminance value, a corresponding effectiveness multiplier can be read or interpolated for three different types of light

sources. (Figure 2-7 can also be used to interpolate multipliers.) The values obtained are listed in the Effectiveness Multiplier row.

- *Step #3: Calculate Illuminance:* AGI calculated the *illuminance* shown in the next line of the comparison. This value is based on the initial lamp lumens for each source as published by the lamp manufacturer. However, because different light sources provide varying levels of visibility at night, *effective* values are a better metric for comparison.
- *Step #4: Determine the effective illuminance:* The effective illuminance is listed in the fourth line for each light source. This is simply the product of the illuminance and the effectiveness multiplier. As shown in the table, metal halide provides higher *effective* illuminance and better *effective* uniformity than an HPS system. This is true even though the metal halide lamp has fewer initial lumens than HPS.

PARKING LOT LIGHTING					
	AVG	MAX	MIN	AVG/MIN	MAX/MIN
250 Watt Metal Halide (150' spacing)					
Step 1: Luminance	0.74	2.1	0.36	2	6
Step 2: Effectiveness Multiplier	1.4	1.3	1.5		
Step 3: Illuminance	1.17	2.43	0.5		
Step 4: Effective Illuminance	1.64	3.04	0.75	2	4
250 Watt HPS (150' spacing)					
Step 1: Luminance	0.81	2.5	0.36	2.3	7.1
Step 2: Effectiveness Multiplier	1	1	1		
Step 3: Illuminance	1.28	3.27	0.58		
Step 4: Effective Illuminance	1.28	3.27	0.58	2	6

Economic Comparison

The next table summarizes an economic comparison of these two light sources for the same parking area. The analysis considered the initial cost of the lighting equipment, the energy costs incurred during the analysis period, and the lamp replacement costs. (The complete cost analysis for HPS, metal halide, and induction lamps can be seen in Appendix D.) The table illustrates that the metal halide source is more expensive for this particular application.

Summary of Total Cost for Analysis Period

Light Type	Luminaire Quantity	Equipment	Energy	Replacement	Total Cost for Analysis Period	Difference for 20 Year Analysis Period	Average Annual Difference
High Pressure Sodium	16	\$25,120	\$24,808	\$5,600	\$55,528		
Metal Halide	16	\$25,280	\$24,220	\$15,360	\$64,860	-\$9,331	-\$467

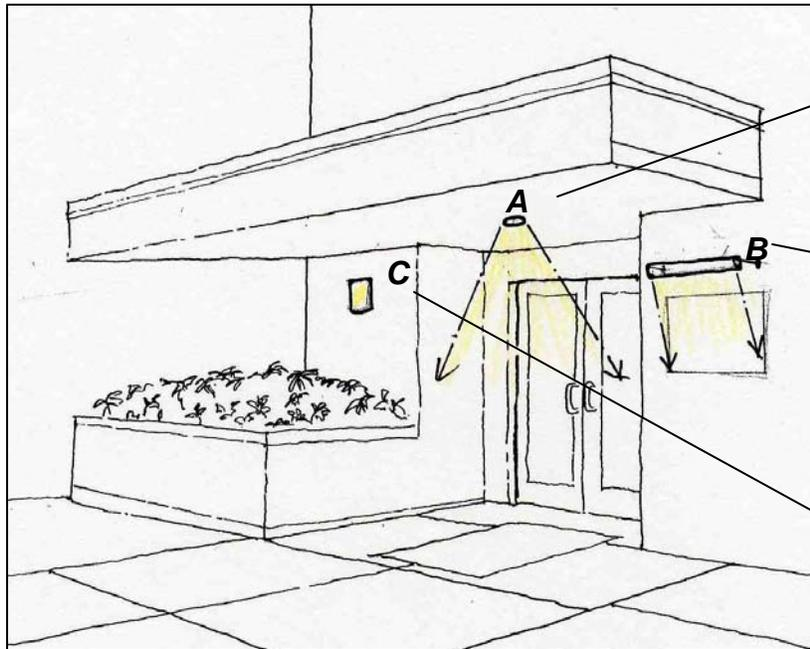
- *Equipment Cost:* Metal halide lamps are slightly more expensive than HPS lamps, increasing the equipment cost.

- *Energy Cost:* Even though the lamps are the same wattage, the actual ballast input wattage for metal halide is lower than HPS. This gives metal halide a small energy cost savings.
- *Lamp Replacement Cost:* The metal halide lamps (with the recommended color temperature of 3000K) have a lower life than HPS. This results in a more frequent replacement of metal halide lamps.

The net additional expense of metal halide may be acceptable if the improved visibility is required for better reaction time or improved security. This analysis compares an equal number of poles and luminaires. Metal halide may become the more cost effective choice as applications increase in size. Because metal halide provides improved illuminance and uniformity, spacing may be increased over a comparable HPS design. If a row of equipment can be reduced with the increased spacing, metal halide will provide savings in all of the cost categories shown in the table.

BUILDING LIGHTING

Entrances



Recessed downlight provides illuminance for egress. Brightness at entry aids in wayfinding and identifies entry.

Wall mounted sign lighter illuminates sign from above, reducing light pollution. Surface brightness at entry aids in wayfinding and identifies entry.

Wall mounted sconce provides surface brightness.

EQUIPMENT RECOMMENDATIONS:

	LUMINAIRE	LAMP	CONTROLS
A	<i>Recessed compact fluorescent downlight.</i>	<i>Compact fluorescent lamp, 3500K color temperature, 80 CRI+</i>	<i>Control with photocell or timeclock.</i>
B	<i>Wall mounted linear fluorescent wall washer.</i>	<i>Linear fluorescent lamps, 3500K color temperature, 75 CRI+</i>	<i>Control with photocell, timeclock, or occupancy sensor.</i>
C	<i>Wall mounted compact fluorescent sconce.</i>	<i>Compact fluorescent lamp, 3500K color temperature, 80 CRI+</i>	<i>Control with photocell or timeclock.</i>

CRITICAL DESIGN ISSUES:

- Appearance of Space and Luminaires: Carefully select luminaires to match the aesthetic character of the building and contribute to a welcome designation to the building entry.
- Direct Glare: Because the surroundings may be very dark at night, consider direct glare from luminaires and excessive contrast of surfaces. Luminaires should use shielded, low wattage lamps.
- Light Distribution on Surfaces: The lighting system should illuminate the walkway uniformly to avoid dark patches. This uniformity is just as important as the light level provided on the walking surface.
- Light Pollution / Trespass: The use of fully shielded or full-cutoff luminaires eliminates direct light above the horizontal plane. While all lighting contributes to light pollution, direct light has the largest

contribution. Using cut-off optics and low wattage lamps can minimize light pollution. Shielded luminaires minimize the chance of light trespass on a neighboring property or building.

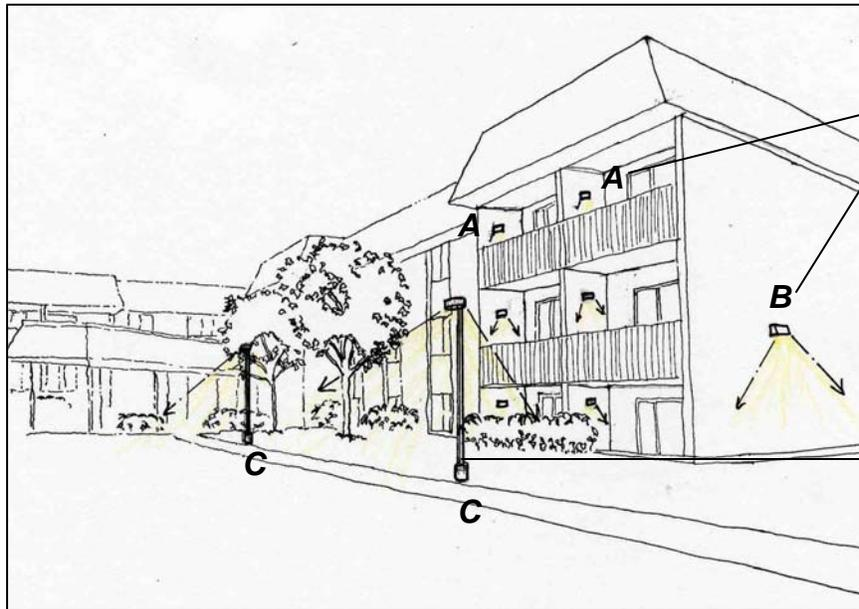
- Modeling of Faces or Objects: By providing vertical illuminance from multiple directions, pedestrians' faces will be visible and accurately rendered.
- Peripheral Detection: Detecting hazards near buildings relies heavily on peripheral vision. Research shows that peripheral vision and detection are enhanced under white light. White light (as opposed to more orange light produced by high-pressure sodium) renders objects sharper and provides excellent peripheral detection compared to high-pressure sodium.
- Point(s) of Interest: Lighting should provide for wayfinding and indicate points of interests, such as the building entry.
- Reflected Glare: Polished surfaces can reflect a lamp image if luminaires are not carefully located. Wet surfaces also often provide a surface that has the potential for reflected glare. Select and locate luminaires to minimize this as much as possible.
- Shadows: Select and locate lighting to eliminate shadows near entries. This increases an individual's sense of security.
- Surface Characteristics: As noted under the reflected glare item, surface characteristics and finishes affect the lighting design. Dark surfaces will reflect little light and may appear dark even when illuminated. Polished (rather than matte) surfaces may reflect a lamp image.
- Vertical Illuminance: Vertical illuminance serves to light objects that may be hazards as well as other pedestrians.
- Target Horizontal Illuminance ($\pm 10\%$): 50 lux (5 footcandles)

DISCUSSION:

Building entrances may use one or all of the luminaire types and strategies outlined. Lighting designs use these concepts to consistently designate a hierarchy of buildings and entries to a single building in addition to providing egress lighting and wayfinding. For example, the main entry to a building should be the brightest and may be the only one with sign lighting. Secondary entrances may be designated with a wall sconce or downlight only. White light, as produced by metal halide, fluorescent, and induction lamps is two to thirty times more effective for nighttime visibility than high-pressure sodium.

BUILDING LIGHTING

Housing Areas



The use of cut-off wall sconces and area lights and downlighting on the façade (rather than uplighting) minimizes light pollution.

Pole mounted pedestrian poles light walkways.

EQUIPMENT RECOMMENDATIONS:

	LUMINAIRE	LAMP	CONTROLS
A	Wall mounted, semi-cutoff, cutoff, or full cut-off sconce.	Compact fluorescent lamp, 3500K color temperature, 80 CRI+	Manual on/off or motion sensor.
B	Wall mounted, fully shielded, cutoff, or full cut-off area light.	Compact fluorescent lamp, 3500K color temperature, 80 CRI+	Control with timeclock or photocell.
C	Pole mounted, cutoff, full cut-off, or shielded pedestrian luminaire.	Metal halide, induction, HPS, or high output compact fluorescent lamp, 3500K color temperature, 80 CRI+	Control with timeclock or photocell.
C ALT	Bollard, (Typically, these luminaires provide poor facial lighting. Best used as indicators rather than for area or pedestrian lighting.)	Compact fluorescent lamp, 3500K color temperature, 80 CRI+	Control with timeclock or photocell.

CRITICAL DESIGN ISSUES:

- **Direct Glare:** Because the surroundings may be very dark at night, consider direct glare from luminaires and excessive contrast of surfaces. Luminaires should use shielded, low wattage lamps.
- **Light Distribution on Surfaces:** Wall mounted luminaires should light the wall or nearby walkways rather than trying to flood light an area. Lighting the wall surface shows people and objects in silhouette, prevents direct glare, and minimizes light pollution.
- **Light Pollution / Trespass:** Fully shielded or IESNA full cut-off luminaires prevent light from leaving the luminaire above the horizontal plane. This

light contributes to light pollution and should be eliminated wherever possible. Shielded luminaires and low wattage lamps minimize the chance of light trespass. Houseside shields also limit spill light onto an adjacent building or property.

- Modeling of Faces or Objects: By providing vertical illuminance from multiple directions, pedestrians' faces will be visible and accurately rendered.
- Peripheral Detection: The detection of hazards near buildings relies heavily on peripheral vision. Research shows that peripheral vision and detection are enhanced under white light. White light (as opposed to more orange light produced by high-pressure sodium) renders objects sharper and provides excellent peripheral detection compared to high-pressure sodium.
- Reflected Glare: Polished surfaces can reflect a lamp image if luminaires are not carefully located. Wet surfaces also provide a surface that has the potential for reflected glare. Select and locate luminaires to minimize this as much as possible.
- Shadows: Select and locate lighting to eliminate shadows near entries. This increases an individual's sense of security.
- Vertical Illuminance: Vertical illuminance serves to light objects that may be hazards as well as other pedestrians.
- Target Horizontal Illuminance ($\pm 10\%$): 5 lux (0.5 fc) on walkways.

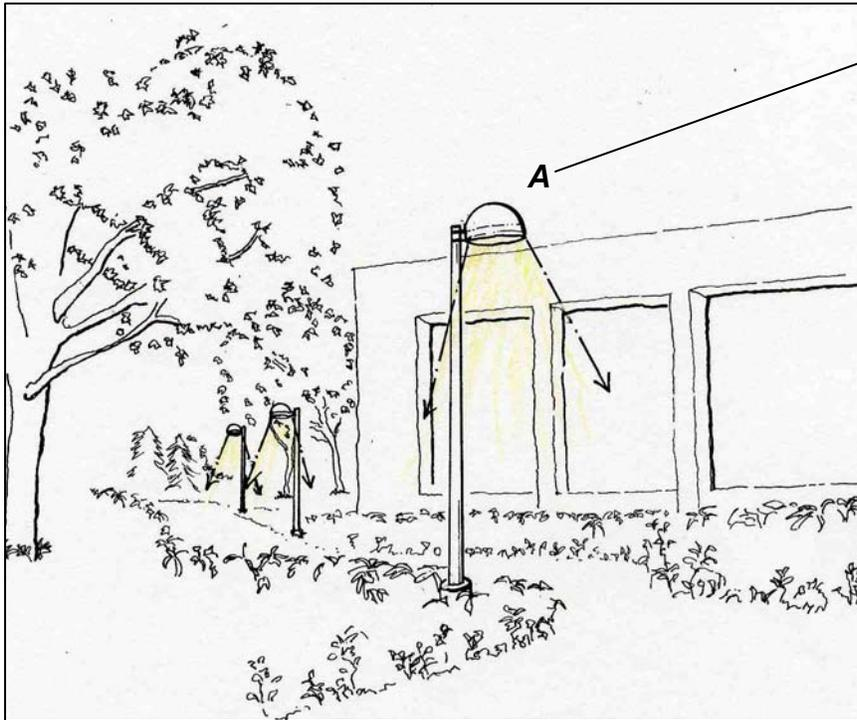
DISCUSSION:

Lighting for housing and the surrounding areas should utilize low wattage lamps and fully shielded or cutoff luminaires to light the building surfaces, prevent glare, and provide a high level of visibility with the minimum light level necessary. When wall mounted luminaires light the wall surface, a soft ambient light is provided without the harsh glare of unshielded floodlights. Avoiding this glare controls contrast while people and objects stand out in silhouette.

Pedestrian poles with fully shielded or cutoff luminaires light paths and walkways with a minimum amount of glare, light trespass, and light pollution. Light trespass in bedroom windows increases the chance of circadian cycle disruption. Well-designed reflectors still provide adequate vertical illuminance to light individuals and possible hazards.

PEDESTRIAN AREAS

Walkways



Low brightness luminaires reduce direct glare and provide adequate vertical illuminance while minimizing light pollution and trespass.

EQUIPMENT RECOMMENDATIONS:

	LUMINAIRE	LAMP	CONTROLS
A	<i>Pole mounted, cutoff, full cutoff or shielded, pedestrian scale luminaire.</i>	<i>50-70 watt coated metal halide, high output compact fluorescent, HPS, or induction lamp.</i>	<i>Photocell or timeclock control.</i>
A ALT	<i>Bollard, (Typically, these luminaires provide poor facial lighting. Best used as indicators rather than for area or pedestrian lighting.)</i>	<i>Compact fluorescent lamp, 3500K color temperature, 80 CRI+</i>	<i>Control with timeclock or photocell.</i>

CRITICAL DESIGN ISSUES:

- Appearance of Space and Luminaires: Match decorative pedestrian poles to the aesthetic character of the adjacent buildings. If the luminaires are not decorative in nature, paint luminaires and poles a neutral color so that they are as inconspicuous as possible.
- Color Appearance and Color Contrast: White light sources, such as metal halide, fluorescent, and induction provide better color rendering than frequently used high- or low-pressure sodium sources.
- Direct Glare: Because the surroundings may be very dark at night, consider direct glare from luminaires and excessive contrast of surfaces. Luminaires should use low wattage lamps.

- Light Pollution / Trespass: The use of fully shielded or full-cutoff luminaires eliminates direct light above the horizontal plane. While all lighting contributes to light pollution, direct light has the largest contribution. Using cut-off optics and low wattage lamps can minimize light pollution. Shielded luminaires minimize the chance of light trespass on a neighboring property or building.
- Modeling of Faces or Objects: By providing vertical illuminance from multiple directions, pedestrians' faces will be visible and accurately rendered.
- Peripheral Detection: Detecting hazards relies heavily on peripheral vision. Research shows that peripheral vision and detection are enhanced under white light. White light (as opposed to more orange light produced by high-pressure sodium) renders objects sharper and provides excellent peripheral detection compared to high-pressure sodium.
- Reflected Glare: Consider the potential for reflected glare based on luminaire location and surface characteristics.
- Shadows: Locate luminaires to eliminate shadows that could hide potential hazards.
- Vertical Illuminance: Adequate vertical illuminance lights possible hazards as well as other pedestrians.
- Target Horizontal Illuminance ($\pm 10\%$): 5 lux (0.5 fc)

DISCUSSION:

Pedestrian walkways using a pedestrian scale poles allow for adequate vertical illuminance to light individuals and their faces. If the luminaires are decorative, a lens or louver should shield the lamp, prevent direct glare, and minimize the possibility of light trespass. Eliminating glare and providing uniformity provides the best security lighting. Low wattage lamps and shielded or cut-off luminaires minimize light pollution.

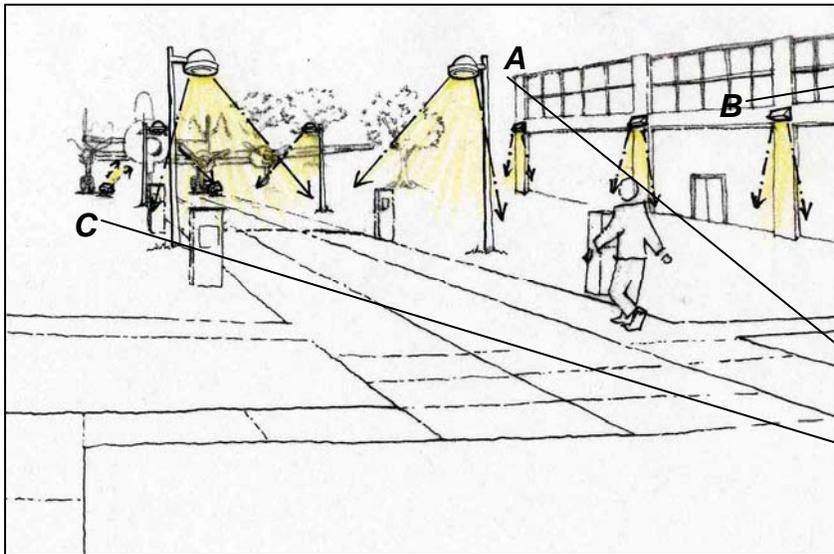
Locate poles in paved areas when possible to avoid blocking irrigation spray heads. When luminaires are positioned in planting areas, locate in shrub rather than lawn areas to avoid damage from mowing and edging.

RULES OF THUMB:

- Mounting Height: Use 3.0 – 4.3 m (10 – 14 ft) poles for pedestrian luminaires.
- Spacing to Mounting Height: When beginning a design, start with an 8:1 spacing to mounting height ratio and modify accordingly to meet critical design issues.
- Locate Poles at Intersections and Nodes. Consider the visual layout of equipment rather than a strict adherence to spacing criteria.

PEDESTRIAN AREAS

Plazas



Building lighting illuminates the perimeter of the plaza and helps to define the exterior "space". This perimeter lighting also provides a sense of security.

Low brightness pedestrian poles reduce direct glare and provide adequate vertical illuminance.

Feature accent lighting highlights focal points of the plaza.

EQUIPMENT RECOMMENDATIONS:

	LUMINAIRE	LAMP	CONTROLS
A	<i>Pole mounted, cutoff, full cutoff or shielded, pedestrian scale luminaire.</i>	<i>50-70 watt coated metal halide, high output compact fluorescent, HPS, or induction lamp.</i>	<i>Photocell/ timclock control.</i>
A ALT	<i>Bollard, (Typically, these luminaires provide poor facial lighting. Best used as indicators rather than for area or pedestrian lighting.)</i>	<i>Compact fluorescent lamp, 3500K color temperature, 80 CRI+</i>	<i>Control with timeclock or photocell.</i>
B	<i>Building mounted, full cutoff downlight / wallwasher.</i>	<i>Compact fluorescent lamp.</i>	<i>Photocell/ timclock control.</i>
C	<i>Accent light.</i>	<i>Compact fluorescent lamp.</i>	<i>Photocell/ timclock control.</i>

CRITICAL DESIGN ISSUES:

- Color Appearance and Color Contrast: White light sources, such as metal halide, fluorescent, and induction provide better color rendering than frequently used high-pressure sodium sources.
- Direct Glare: Because the surroundings may be very dark at night, consider direct glare from luminaires and excessive contrast of surfaces. Luminaires should use shielded, low wattage lamps.
- Light Pollution / Trespass: The use of fully shielded or full-cutoff luminaires eliminates direct light above the horizontal plane. While all lighting contributes to light pollution, direct light has the largest contribution. Using shielded or cut-off optics and low wattage lamps can minimize light pollution. Shielded luminaires minimize the chance of light trespass on a neighboring property or building.

- Modeling of Faces or Objects: By providing vertical illuminance from multiple directions, pedestrians' faces will be visible and accurately rendered.
- Peripheral Detection: Detecting hazards relies heavily on peripheral vision. Research shows that peripheral vision and detection are enhanced under white light. White light (as opposed to more orange light produced by high-pressure sodium) renders objects sharper and provides excellent peripheral detection compared to high-pressure sodium. Lighting the facades of surrounding buildings with low glare lighting silhouettes objects and improves peripheral detection.
- Reflected Glare: Consider the potential for reflected glare based on luminaire location and surface characteristics.
- Shadows: Locate luminaires to eliminate shadows that could hide potential hazards.
- Vertical Illuminance: Adequate vertical illuminance lights possible hazards as well as other pedestrians.
- Target Horizontal Illuminance ($\pm 10\%$): 5 lux (0.5 fc)

DISCUSSION:

Plazas using pedestrian scale poles provide adequate vertical illuminance to light individuals and their faces. If the luminaires are decorative, a lens or louver should shield the lamp, prevent direct glare, and minimize the possibility of light trespass. Low wattage lamps and shielded or cut-off luminaires minimize light pollution.

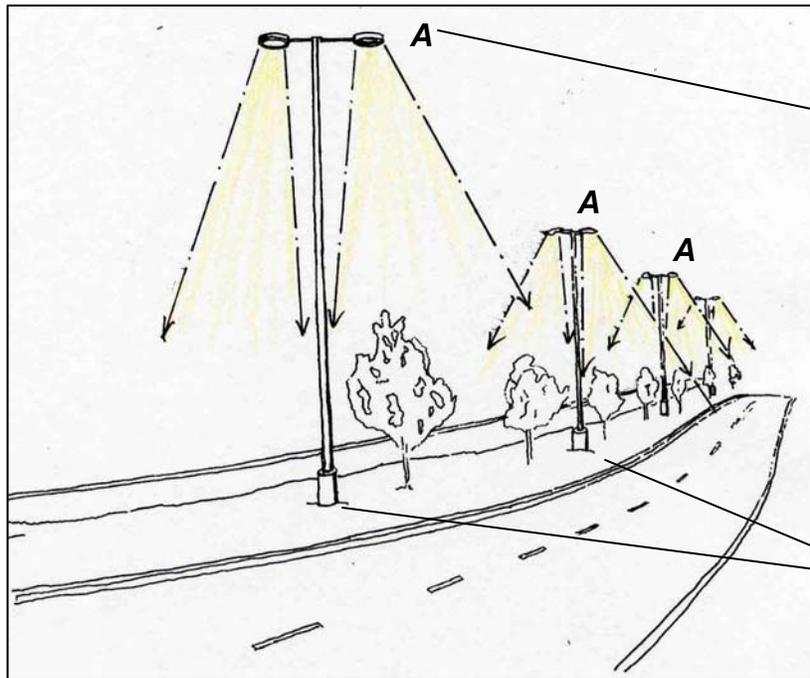
Selectively lighting the facades of surrounding buildings helps to create the sense of an exterior space. By silhouetting objects, this technique increases visibility and improves peripheral detection.

Carefully select features to accent; consider viewing angles, glare, and light pollution and trespass. Low wattage lamps and the controlled downlighting of surfaces provide the best opportunities. If uplight cannot be avoided, control the light so that the luminaires are lighting the feature only, minimizing spill. Shield the luminaires to prevent glare and light trespass and minimize light pollution. Consider using the lighting only at specific times or for special occasions.

Locate poles in paved areas when possible to avoid blocking irrigation spray heads. When luminaires are positioned in planting areas, locate in shrub rather than lawn areas to avoid damage from mowing and edging.

VEHICLE TRAFFIC AREAS

Roadways and Streets



Fully shielded or full cut-off luminaires control glare and reduce light pollution and trespass.

Spacing luminaires 4-5 times the mounting height provides uniform horizontal illuminance.

EQUIPMENT RECOMMENDATIONS:

	LUMINAIRE	LAMP	CONTROLS
A	Pole mounted, fully shielded or full cut-off roadway luminaire.	Metal halide, induction, or high-pressure sodium lamp.	Photocell on/off.

CRITICAL DESIGN ISSUES:

- Appearance of Space and Luminaires: Paint luminaires and poles a neutral color so that they are as inconspicuous as possible.
- Direct Glare: Fully shielded or full cut-off luminaires conceal the light source and minimize the direct glare from the luminaire. Because the eye adjusts to the brightest source in the field of view, eliminating glare is the highest priority in designing for nighttime driving.
- Light Distribution on Surfaces: More important than light level, uniform light distribution provides high visibility and a comfortable nighttime driving environment.
- Light Pollution / Trespass: Fully shielded or full cut-off luminaires prevent any direct light from leaving the luminaire above horizontal. This direct light is the largest contributor to light pollution and light trespass.
- Peripheral Detection: Detecting hazards while driving relies heavily on peripheral vision. Research shows that peripheral vision and detection are enhanced under white light. White light (as opposed to more orange light produced by high-pressure sodium) renders objects sharper and

provides excellent peripheral detection compared to high-pressure sodium.

- Reflected Glare: Wet surfaces often provide a surface that has the potential for reflected glare. Select and locate luminaires to minimize this as much as possible.
- Shadows: Locate luminaires to eliminate shadows that could hide potential hazards.
- Source / Task / Eye Geometry: Consider the angles between the driver, the luminaires, and the tasks. The tasks may be just the roadway or it may be pedestrians in a crosswalk or other cars at an intersection.
- Vertical Illuminance: Vertical illuminance serves to light objects that may be hazards as well as pedestrians that may be near a roadway or in an intersection. See IESNA RP-8-00.
- Small Target Visibility (STV): Varies, based on application. See IESNA RP-8.
- Luminance: Varies, based on application. See IESNA RP-8-00.

DISCUSSION:

The visual environment needs along the roadway can be described in terms of pavement illuminance and luminance, uniformity and direct glare produced by the light sources. (*Lighting Handbook* page 22-9).

There are three calculation methods available for roadway design: small target visibility, luminance and illuminance. Since Roadway lighting is a specialized design area, refer to IESNA RP-8-00 for specific design criteria.

Small target visibility (STV) is the preferred method since it best accounts for identifying an object or pedestrian crossing the roadway. In order to achieve a high STV, luminaire placement and arrangement is critical. For example, median mounted poles or poles lined up opposite each other produce the highest STV values. A staggered pole arrangement produces the lowest STV values. If safety is a concern, then the preferred method is small target visibility.

Luminance method calculates the pavement brightness as seen by a motorist. The glare potential from the roadway luminaires is taken into account with the veiling luminance calculation. The Luminance method is an excellent alternative method since it realistically models the pavement brightness and its uniformity.

The Illuminance method is not recommended since it usually produces poor STV results. Traditionally, the illuminance method was used in roadway calculations since it is simple to calculate and obtain field measurements.

The recommendation is to use STV first and luminance method as a final check for roadway lighting quality.

For roadway lighting applications where peripheral vision is important such as detecting pedestrians or potential off axis activity, white light as produced by a metal halide, fluorescent, or induction lamp is recommended. In addition to providing better visibility,

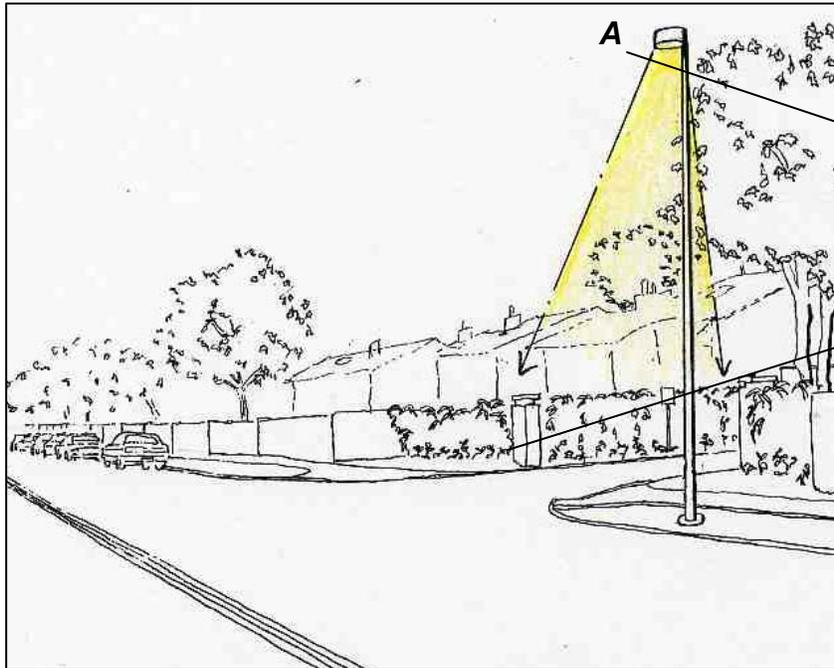
this has an energy impact as well. The same visibility can be provided with a lower level of white light that would require a higher level of HPS light.

RULES OF THUMB:

- Spacing to Mounting Height: When beginning a design, start with a 5:1 spacing to mounting height ratio and modify accordingly to meet critical design issues.

VEHICLE TRAFFIC AREAS

Driveways



Fully shielded or Full cut-off luminaires control glare and reduce light pollution and trespass.

Luminaire serves to identify driveway location and pedestrians crossing the driveway.

EQUIPMENT RECOMMENDATIONS:

	LUMINAIRE	LAMP	CONTROLS
A	<i>Pole mounted full cut-off roadway luminaire.</i>	<i>Metal halide, HPS, or induction lamp.</i>	<i>Control with timer or photocell.</i>

CRITICAL DESIGN ISSUES:

- **Direct Glare:** Full cut-off luminaires conceal the light source and minimize the direct glare from the luminaire. Because the eye adjusts to the brightest source in the field of view, eliminating glare is the highest priority in designing for nighttime driving.
- **Light Pollution / Trespass:** Fully shielded or full cut-off luminaires prevent any direct light from leaving the luminaire above horizontal. This direct light is the largest contributor to light pollution and light trespass.
- **Modeling of Faces or Objects:** Luminaires need to provide adequate vertical illuminance to light people and their faces. Provide vertical light on pedestrians crossing the street by locating the pole ahead of the cross walk.
- **Peripheral Detection:** Detecting hazards while driving relies heavily on peripheral vision. Research shows that peripheral vision and detection are enhanced under white light. White light (as opposed to more orange light produced by high-pressure sodium) renders objects sharper and provides excellent peripheral detection compared to high-pressure sodium.

- Shadows: Locate and select luminaires to provide a uniform illuminance on the ground and eliminate dark spots and shadows. Such dark spots can be distracting to drivers and also may conceal hazards.
- Vertical Illuminance: Pole location, height, and luminaire selection all contribute to adequate vertical illuminance.
- Target Horizontal Illuminance ($\pm 10\%$): Varies with type of surrounding environment.

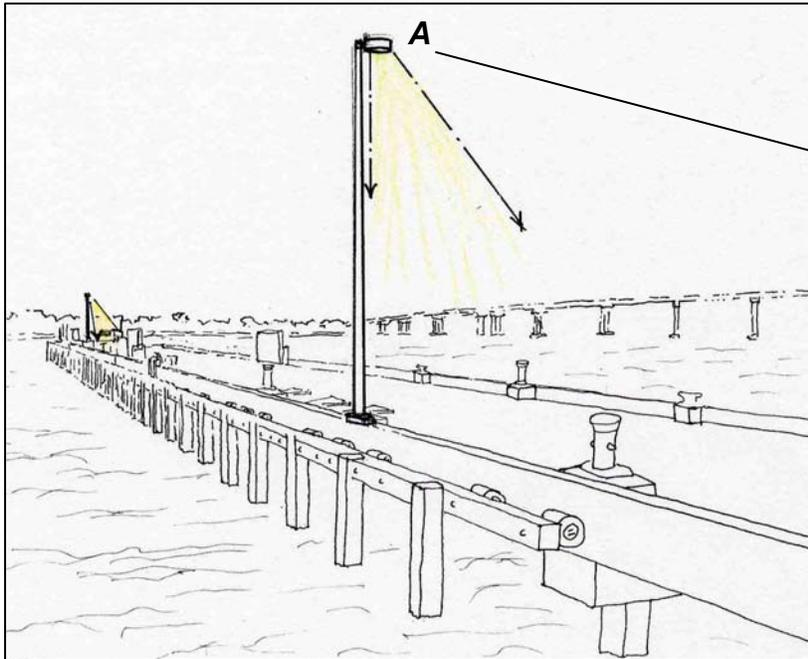
DISCUSSION:

Research shows that peripheral vision and detection are enhanced under white light. White light (as opposed to more orange light produced by high-pressure sodium) renders objects sharper and provides excellent peripheral detection compared to high-pressure sodium. This peripheral detection is critical at points where other vehicles may be entering a roadway and pedestrians may be crossing the street.

In addition to providing better visibility, this has an energy impact as well. The same visibility can be provided with a lower level of white light that would require a higher level of HPS light.

Luminaires should use shielded sources with cutoff reflectors to minimize light pollution and light trespass.

MARINAS



Fully shielded or full cut-off luminaires control glare and reduce light pollution and trespass.

EQUIPMENT RECOMMENDATIONS:

	LUMINAIRE	LAMP	CONTROLS
A	<i>Pole mounted metal halide, HPS, or induction luminaire.</i>	<i>Coated metal halide, induction, or high-pressure sodium lamp. Use low-pressure sodium lamps in sea turtle nesting areas.</i>	<i>Control with photocell, timeclock, or motion sensor.</i>

CRITICAL DESIGN ISSUES:

- **Direct Glare:** Fully shielded or full cut-off, flat-lens luminaires conceal the light source and minimize the direct glare from the luminaire. Because the eye adjusts to the brightest source in the field of view, eliminating glare is the highest priority in designing for nighttime, exterior tasks.
- **Light Pollution / Trespass:** The use of fully shielded or full-cutoff luminaires eliminates direct light above the horizontal plane. Using full cut-off optics and low wattage lamps can minimize light pollution. Shielded luminaires minimize the chance of light trespass on a neighboring property or building.
- **Modeling of Faces or Objects:** By providing light from multiple directions, objects and people are accurately rendered and modeled.
- **Reflected Glare:** Wet surfaces often provide a surface that has the potential for reflected glare. Select and locate luminaires and choose surface finishes to minimize this as much as possible.

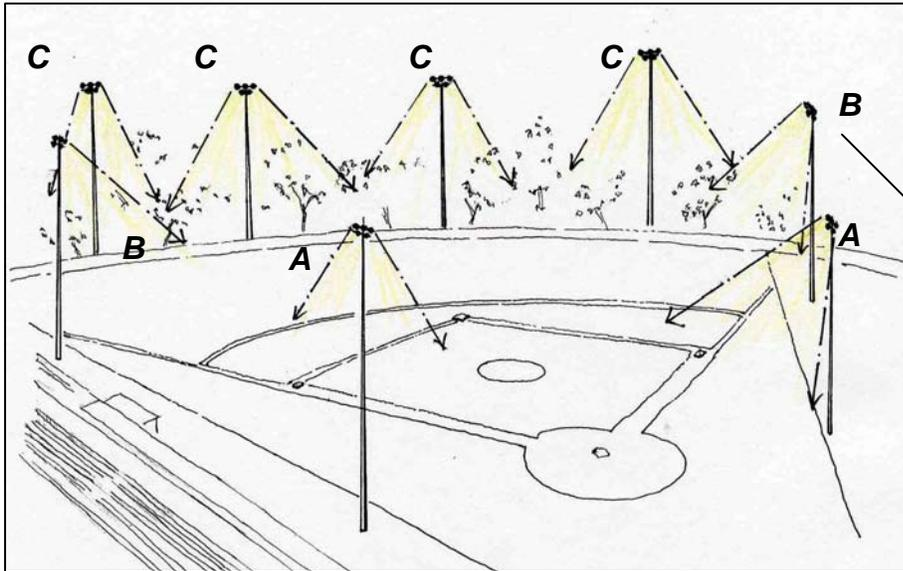
- Shadows: Locate and space poles for maximum uniformity and so that the light from the luminaires minimizes shadows that could conceal potential hazards.
- Source / Task / Eye Geometry: Luminaire locations and pole heights need to be determined while considering the location and viewing angles of typical tasks. Keep light sources out of the field of view as much as possible.
- Target Horizontal Illuminance ($\pm 10\%$): 50 lux (5 fc)

DISCUSSION:

The use of fully shielded or full cutoff luminaires with flat lenses, in addition to the lowest wattage lamp that will adequately meet light level requirements, minimizes light pollution and the chance of direct glare. Research shows that peripheral vision and detection are enhanced under white light. White light (as opposed to more orange light produced by high-pressure sodium) renders objects sharper and provides excellent peripheral detection compared to high-pressure sodium. Use low-pressure sodium lamps in sea turtle nesting areas.

EXTERIOR RECREATIONAL AREAS

Baseball & Softball Fields



Luminaire locations provide vertical illuminance on the field while minimizing glare from critical viewing angles.

EQUIPMENT RECOMMENDATIONS:

	LUMINAIRE	LAMP	CONTROLS
A	<i>Pole mounted modular rack of adjustable floodlights. Distribution types 2, 3, and 4 with internal and external shielding.</i>	<i>Metal halide.</i>	<i>Manual on/off</i>
B	<i>Pole mounted modular rack of adjustable floodlights. Distribution types 2, 3, 4, and 5 with internal and external shielding.</i>	<i>Metal halide.</i>	<i>Manual on/off</i>
C	<i>Pole mounted modular rack of adjustable floodlights. Distribution types 4, 5, and 6 with internal and external.</i>	<i>Metal halide.</i>	<i>Manual on/off</i>

CRITICAL DESIGN ISSUES:

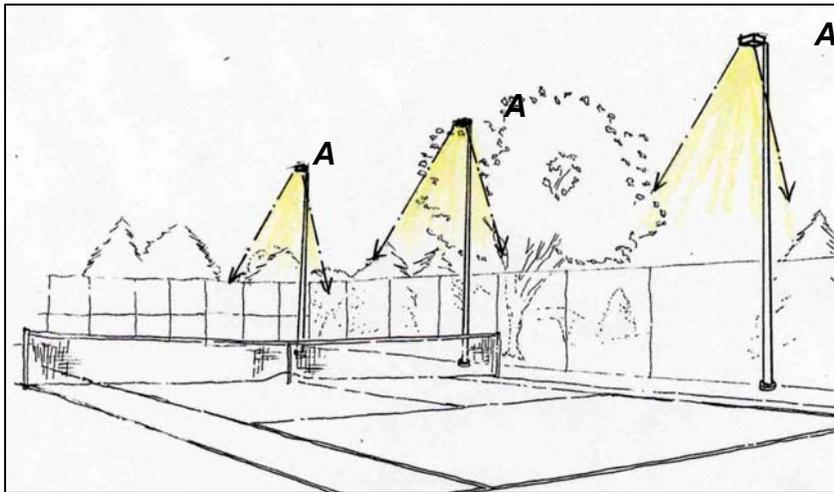
- **Direct Glare:** In a game where the ball is traveling at high speeds and all possible angles, minimize glare to provide adequate visibility. IESNA RP-6-01 outlines critical glare zones where poles should not be located. This way, when a player follows the ball, they will not look directly into a floodlight.
- **Light Distribution on Task Plane (Uniformity):** Floodlight locations and distribution provide uniform illuminance on the field. The uniformity and elimination of dark spots improves visibility and minimizes distractions.
- **Target Horizontal Illuminance ($\pm 10\%$):** For various classes of play and illuminance recommendations see *Lighting Handbook*, Figure 20-2 and IESNA RP-6.

DISCUSSION:

The lighting for baseball and softball fields should illuminate the field uniformly and also from multiple angles to eliminate dark spots and model the ball accurately. The poles should not be located in zones where luminaire glare would be critical. IESNA RP-6-01 outlines these zones where players may follow the ball's path and look directly into a luminaire. This glare impairs visibility, as the ball may be lost from sight. All floodlights should have internal and external shielding to increase player visibility and decrease light trespass. Lighting templates with pole and luminaire data are readily available from sports lighting manufacturers.

EXTERIOR RECREATIONAL AREAS

Tennis Courts



Pole mounted area lights provide minimum glare and uniform illuminance on the court.

EQUIPMENT RECOMMENDATIONS:

	LUMINAIRE	LAMP	CONTROLS
A	<i>Pole mounted, fully shielded or full cut-off area luminaire.</i>	<i>Coated metal halide, fluorescent, or induction.</i>	<i>Timer switch, motion sensor, or manual on/off with a timeclock.</i>

CRITICAL DESIGN ISSUES:

- Direct Glare: Locate luminaires parallel to the direction of play to minimize the chance of looking up into the luminaires. Flat lensed and fully shielded or full cut-off luminaires also reduce luminaire brightness and direct glare.
- Flicker (and Strobe): Specify electronic ballasts to prevent flicker and stroboscopic effects.
- Light Distribution on Task Plane: Space luminaires appropriately to provide a uniform distribution of light on the court.
- Modeling of Faces or Objects: Light should come from multiple directions to accurately render the ball and other players.
- Vertical Illuminance: Adequate vertical illuminance is necessary to see the ball at all angles.
- Target Horizontal Illuminance ($\pm 10\%$): For various classes of play and illuminance recommendations see *Lighting Handbook*, Figure 20-2 and IESNA RP-6-01.

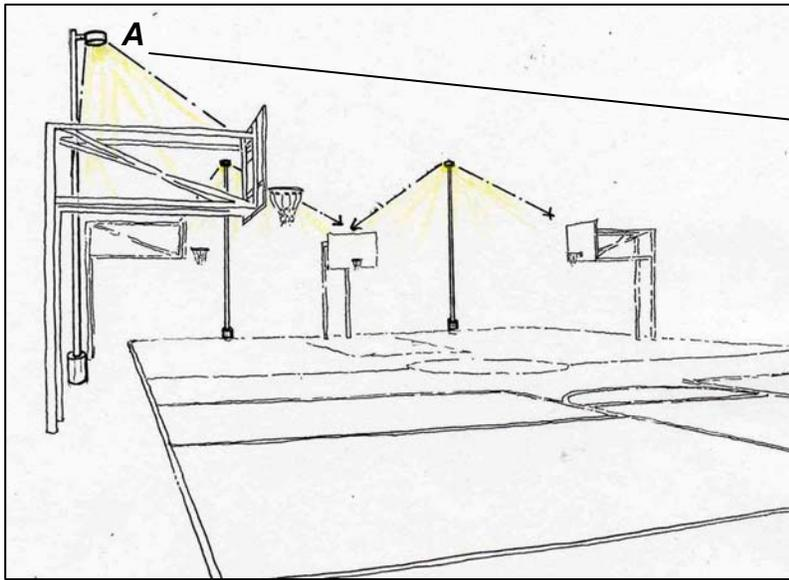
DISCUSSION:

Illuminate tennis courts from the sides of the court, minimizing the chance of players looking directly into a luminaire during play. Uniform horizontal and vertical illuminance is important to accurately model a ball at high speed. Lighting templates with pole and luminaire data are readily available from sports lighting manufacturers.

The lighting system should be controlled by a time clock or from an office location if the facility is part of a fitness center. Approximately one half of the luminaires should remain on per timeclock settings. The other half of the luminaires can have local control, perhaps on a timer.

EXTERIOR RECREATIONAL AREAS

Basketball Courts



Pole mounted luminaires are spaced to provide uniform illuminance and minimize direct glare.

EQUIPMENT RECOMMENDATIONS:

	LUMINAIRE	LAMP	CONTROLS
A	<i>Pole mounted metal halide or induction area light.</i>	<i>Coated metal halide or induction lamp.</i>	<i>Control with photocell, timeclock, or motion sensor (induction lamp only).</i>

CRITICAL DESIGN ISSUES:

- **Direct Glare:** Space pole mounted luminaires located around a court to minimize direct glare when looking at the basket. Flat lensed and fully shielded or full cut-off luminaires also reduce luminaire brightness and direct glare.
- **Light Distribution on Task Plane (Uniformity):** Space luminaires appropriately to provide a uniform distribution of light on the court. By locating luminaires around the court, the uniformity can be achieved while avoiding direct glare and still lighting the basket from multiple angles.
- **Target Horizontal Illuminance ($\pm 10\%$):** For various classes of play and illuminance recommendations see *Lighting Handbook*, Figure 20-2 and IESNA RP-6.

DISCUSSION:

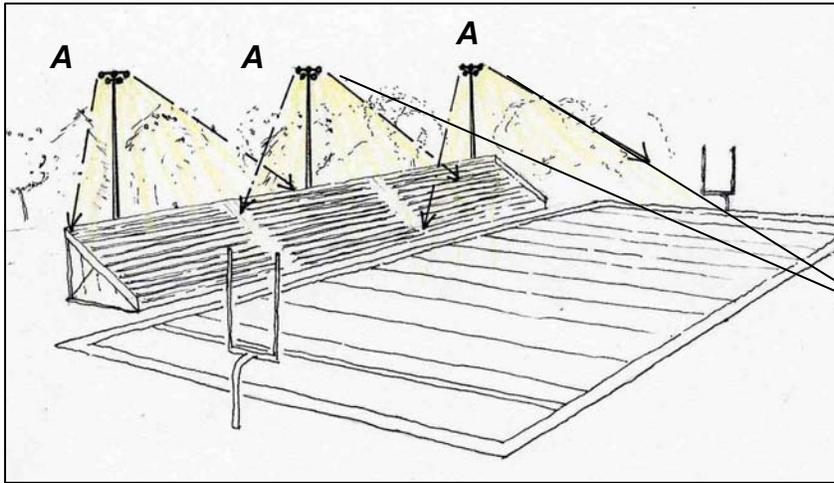
No matter where poles are located along the boundary of the court, there is the chance of direct glare due to the variety of angles that players view the baskets. This can be minimized by not locating poles directly behind the basket. If poles flank the basket, there is less of a chance of looking into the luminaire when shooting. By locating luminaires around the court, the basket will be illuminated from multiple angles. Lighting

templates with pole and luminaire data are readily available from sports lighting manufacturers.

The lighting system should be controlled by a time clock or from an office location if the facility is part of a fitness center. Approximately one half of the luminaires should remain on per timeclock settings. The other half of the luminaires can have local control, perhaps on a timer.

EXTERIOR RECREATIONAL AREAS

Football Fields



Luminaire spacing provides uniform illuminance on the field.

EQUIPMENT RECOMMENDATIONS:

	LUMINAIRE	LAMP	CONTROLS
A	<i>Pole mounted modular rack of adjustable floodlights with internal and external shielding.</i>	<i>Metal halide.</i>	<i>Manual on/off.</i>

CRITICAL DESIGN ISSUES:

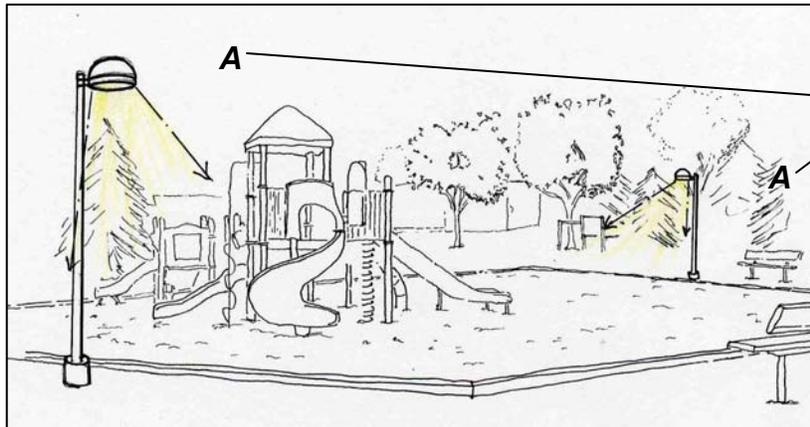
- Direct Glare: By locating the light poles along the sides of the field and parallel to the general direction of play, the field is illuminated from multiple angles while minimizing the chance of looking directly into a luminaire. Minimize direct glare to enhance visibility.
- Light Distribution on Task Plane (Uniformity): Luminaire locations and distribution provide uniform illuminance on the field. The uniformity and elimination of dark spots improves visibility and minimizes distractions.
- Target Horizontal Illuminance ($\pm 10\%$): For various classes of play and illuminance recommendations see *Lighting Handbook*, Figure 20-2 and IESNA RP-6.

DISCUSSION:

The lighting for football fields should illuminate the field uniformly and also from multiple angles to eliminate dark spots and model the ball and players accurately. Poles located parallel to the direction of play minimize the direct glare. Pole quantity depends on the setback distance from the field, with fewer poles required when they are further away. Refer to IESNA RP-6-01 for more details. Lighting templates with pole and luminaire data are readily available from sports lighting manufacturers.

EXTERIOR RECREATIONAL AREAS

Playgrounds



Pedestrian poles around the playground uniformly illuminate the area.

EQUIPMENT RECOMMENDATIONS:

	LUMINAIRE	LAMP	CONTROLS
A	<i>Pole mounted, shielded or cutoff pedestrian scale luminaire.</i>	<i>Coated metal halide, induction, HPS, or compact fluorescent.</i>	<i>Control with photocell, timeclock, or motion sensor (induction and compact fluorescent lamps only).</i>

CRITICAL DESIGN ISSUES:

- Light Distribution on Task Plane (Uniformity): Select and locate pedestrian poles to uniformly illuminate the area.
- Shadows: Locate and space luminaires to eliminate shadows that could hide potential hazards. Light from multiple angles will provide adequate visibility on the playground equipment.
- Target Horizontal Illuminance ($\pm 10\%$): 50 lux (5 fc)

DISCUSSION:

Illuminate playgrounds with security as the intent. They typically will not be used at night so the equipment does not need to be illuminated. Locate lighting to eliminate shadows or dark areas. Placement must also avoid all playground equipment safety zones, as defined by the playground equipment manufacturer.

APPENDIX A

REFERENCES

1. American National Standards Institute

www.ansi.org

ANSI A17.1, *Safety Code for Elevators and Escalators*

ANSI A17.2, *Safety Code for Existing Elevators and Escalators*

ANSI C2-2002, *National Electrical Safety Code*
2. American Society of Heating, Refrigeration, and Air Conditioning Engineers (ASHRAE)

ASHRAE/IESNA/ANSI 90.1-1999, *Energy Efficient Design of New Buildings Except Low-Rise Residential Buildings*
3. Defense Logistics Agency
General and Industrial Lighting

1-800-DLA-BULB
<http://dscp103.dscp.dla.mil/gi/general/light1.htm>
4. Department of Defense Unified Facilities Criteria

UFC 4-011-02, *Security Engineering Design Manual*

UFC 4-721-10, *Design: Navy and Marine Corps Bachelor Housing*

UFC 4-721-11.1, *Design: Unaccompanied Enlisted Personnel Housing (UEPH) Complexes*

UFC 4-722-01, *Design: Dining Facilities*

UFC 4-740-02N, *Design: Indoor Recreation Facilities*
http://energy.navy.mil/publications/law_us/92epact/hr776toc.htm
5. Energy Policy Act of 1992
6. Ernest Orlando Lawrence Berkeley National Laboratory
www.lbl.gov

Tips for Daylighting with Windows, The Integrated Approach.
7. Federal Energy Management Program (FEMP)

“Lighting Resources”

Economics for Energy Effective Lighting for

- www.eere.energy.gov/fe mp Offices
8. The Heschong Mahone Group
www.h-m-g.com “Daylighting in Schools”
“Skylighting and Retail Sales”
Skylighting Guidelines (SkyCalc)
9. Illuminating Engineering Society of North America *Lighting Handbook Reference and Application, Ninth Edition, 2000*
RP-6, Recommended Practice for Sports and Recreational Area Lighting, 2001; Errata 2004
RP-8, Roadway Lighting, 2000; Errata 2004
RP-21, Calculation of Daylight Availability, 1984
RP-23, Lumen Method of Daylight Calculations, 1989
RR-03, IESNA Lighting Ready Reference, Fourth Edition
10. Light Right Consortium www.lightright.org
11. Lighting Research Center,
Rensselaer Polytechnic Institute *Evaluation of Visual Function Under Different Light Sources, December 11, 1995*
12. National Electrical Contractors Association (NECA) *NECA/IESNA 500, 1998, Recommended Practice for Installation of Commercial Lighting Systems (ANSI)*
NECA/IESNA 502, 1999, Recommended Practice for Installing Industrial Lighting Systems (ANSI)
13. National Fire Protection Association *NFPA 70, National Electrical Code*
NFPA 101, Life Safety Code
14. Naval Facilities Engineering Command *MIL-HDBK-1013/1A, Design Guidelines for Physical Security of Buildings*
NAVFAC INSTRUCTION 9830.1, Sustainable Development Policy

15. New Buildings Institute, Inc.
www.newbuildings.org
Advanced Lighting Guidelines, 2001 Edition
16. US Army Corps of Engineers Publications
<http://www.cecer.army.mil/sustdesign/SPiRiT.cfm>
Sustainable Project Rating Tool (SPiRiT)
CECW-EE (1110), *Sustainable Design and Development*
17. US Department of Energy, Energy Efficiency and Renewable Energy
TI 811-16, *Lighting Design National Best Practices Manual, Daylighting and Windows*
Energy Efficiency and Renewable Energy Building Tools Directory at
http://www.eere.energy.gov/building/tools_directory/
18. US Green Building Council
www.usgbc.org
LEED Reference Guide (Current Version: 2.0, see website for most current version)
19. Whole Building Design Guide
<http://www.wbdg.org/>

APPENDIX B

PHYSIOLOGICAL ISSUES

B-1 Light quality and quantity can have profound physical and psychological effects. In addition to the eye fatigue that can be caused by direct and reflected glare, lighting also affects Seasonal Affective Disorder (SAD), sleep disorders, and jet lag.

B-1.1 Seasonal Affective Disorder (SAD) is a clinical condition brought about by the shorter days and less sunlight during fall and winter seasons. Symptoms include a loss of physical energy as well as emotional depression, increase in sleep requirements, and an increase in appetite. Light therapy has been used to treat SAD where patients are exposed to levels of light significantly higher than those typically provided indoors. The therapy depends more on the quantity of light, than the light source. Introducing daylight into interior spaces is the best architectural solution for SAD.

B-1.2 Sleep disorders. Because of the connection between light and sleep cycles, scientists expect that light therapy can be used to treat some sleep disorders. However, no recommendations have yet been developed for such therapy. Because circadian cycles depend on daylight during the day and darkness while sleeping, it is extremely important to expose people to daylight during the day and eliminate or minimize light in sleeping areas.

B-1.3 Jet lag results in a variety of symptoms ranging from sleep disruption to digestion problems. Similar to sleep disorders, scientists expect that light therapy can be used to overcome jet lag and its negative effects faster than the natural adjustment period.

APPENDIX C

GLOSSARY OF LIGHTING TERMS¹

Abbreviations and Acronyms:

ANSI – American National Standards Institute

ASHRAE – American Society of Heating, Refrigerating, and Air-Conditioning Engineers

CCT – Correlated Color Temperature

CRI – Color Rendering Index

DOE – Department of Energy

EPA – Environmental Protection Agency

FEMP – Federal Energy Management Program

HID – High-Intensity Discharge

HVAC – Heating, Ventilating, and Cooling

Hz – Hertz

IESNA – Illuminating Engineering Society of North America

kW – Kilowatts

kWh – Kilowatt Hours

LEC – Light Emitting Capacitor

LED – Light Emitting Diode

LLD – Lamp Lumen Depreciation

NEC – National Electric Code

NECA – National Electrical Contractors Association

NEMA – National Electrical Manufacturers Association

NESC – National Electrical Safety Code

NFPA – National Fire Protection Association

O&M – Operations and Maintenance

RFI – Radio Frequency Interference

SAD – Seasonal Affective Disorder

SF – Square Foot

THD – Total Harmonic Distortion

¹ All definitions taken from "Glossary of Lighting Terminology", *The IESNA Lighting Handbook*, Chapter G, Ninth Edition (New York: The Illuminating Engineering Society of North America, 2000), p. G-1.

UFGS – Unified Facilities Guide Specifications

UL – Underwriters Laboratories

V – Volt

W - Watts

Terms:

Adaptation – the process by which the retina becomes accustomed to more or less light than it was exposed to during an immediately preceding period. It results in a change in the sensitivity to light.

Altitude – the angular distance of a heavenly body measured on the great circle that passes perpendicular to the plane of the horizon, through the body and through the zenith. It is measure positively from the horizon to the zenith, from 0 degrees to 90 degrees.

Ambient Lighting – lighting throughout an area that produces general illumination

Area Lighting Luminaire – a complete lighting device consisting of a light source and ballast, where appropriate, together with its direct appurtenances such as globe, reflector, refractor, housing, and such support as is integral with the housing. The pole, post, or bracket is not considered part of the luminaire.

Average Luminance – luminance is a property of a geometric ray. Luminance as measured by conventional meters is averaged with respect to two independent variables, area and solid angle; both must be defined for a complete description of a luminance measurement.

Azimuth – the angular distance between the vertical plane containing a given line or celestial body and the plane of the meridian.

Baffle – a single opaque or translucent element to shield a source from direct view at certain angles, to absorb or block unwanted light, or to reflect and redirect light.

Ballast – a device used with an electric-discharge lamp to obtain the necessary circuit conditions (voltage, current, and waveform) for starting and operating.

Ballast Factor – the fractional flux of a fluorescent lamp operated on a ballast compared to the flux when operated on the standard (reference) ballast specified for rating lamp lumens.

Bollard – luminaires having the appearance of a short, thick post, used for walkway and grounds lighting. The optical components are usually top-mounted.

Bowl – an open-top diffusing glass or plastic enclosure used to shield a light source from direct view and to redirect or scatter the light.

Bracket (mast arm) – an attachment to a lamp post or pole from which a luminaire is suspended.

Candela, cd – the SI unit of luminous intensity, equal to one lumen per steradian

(lm/sr).

Candlepower (cp), $I = d\phi/d\omega$ - luminous intensity expressed in candelas.

Clerestory – that part of a building that rises clear of the roofs or other parts and whose walls contain windows for lighting the interior.

Coefficient of Utilization (CU) – the ratio of luminous flux (lumens) calculated as received on the work plane to the total luminous flux (lumens) emitted by the lamps alone. It is equal to the product of room utilization factor and luminaire efficiency.

Color Matching – the action of making a color appear the same as a given color.

Color Rendering – a general expression for the effect of a light source on the color appearance of objects in conscious or subconscious comparison with their color appearance under a reference light source.

Color Rendering Index (of a light source) (CRI) – a measure of the degree of color shift objects undergo when illuminated by the light source as compared with those same objects when illuminated by a reference source of comparable color temperature.

Color Temperature (of a light source) – the absolute temperature of a blackbody radiator having a chromaticity equal to that of the light source. Refer to Correlated Color Temperature.

Contrast – see *luminance contrast*.

Correlated Color Temperature (of a light source) (CCT) – the absolute temperature of a blackbody whose chromaticity most nearly resembles that of the light source.

Daylight Availability – the luminous flux from the sun plus sky at a specific location, time, date, and sky condition.

Diffused Lighting – lighting provided on the work plane or on an object that is not incident predominantly from any particular direction.

Dimmer – a device used to control the intensity of light emitted by a luminaire by controlling the voltage or current available to it.

Direct Component – that portion of the light from a luminaire that arrives at the work plane without being reflected by room surfaces.

Direct Glare – glare resulting from high luminances or insufficiently shielded light sources in the field of view. It is usually associated with bright areas, such as luminaires, ceilings, and windows that are outside the visual task or region being viewed. A direct glare source can also affect performance by distracting attention.

Direct-Indirect Lighting – a variant of general diffuse lighting in which the luminaires emit little or no light at angles near the horizontal.

Direct Lighting – lighting involves luminaires that distribute 90 to 100% of the emitted light in the general direction of the surface to be illuminated. The term usually refers to light emitted in a downward direction.

Directional Lighting – lighting provided on the workplane or on an object. Light that is predominantly from a preferred direction.

Disability Glare – the effect of stray light in the eye whereby visibility and visual performance are reduced. A direct glare source that produces discomfort can also produce disability glare by introducing a measurable amount of stray light in the eye.

Discomfort Glare – glare that produces discomfort. It does not necessarily interfere with visual performance or visibility.

Downlight – a small direct lighting unit that directs the light downward and can be recessed, surface-mounted, or suspended.

Efficacy – See *luminous efficacy of a source of light*.

Efficiency – See *luminaire efficiency*.

Electroluminescence – the emission of light from a phosphor excited by an electromagnetic field.

Emergency Exit – a way out of the premises that is intended to be used only during an emergency.

Emergency Lighting – lighting designed to supply illumination essential to the safety of life and property in the event of a failure of the normal supply. The system must be capable of providing minimum required illuminance specified in NFPA 101, *Code for Safety to Life from Fire in Buildings and Structures*, Section 5.9.

Exit sign – a graphic device including words or symbols that indicates or identifies an escape route or the location of, or direct to, an exit or emergency exit.

Floodlight – a projector designed for lighting a scene or object to a luminance considerably greater than its surroundings.

Fluorescent lamp – a low pressure mercury electric-discharge lamp in which a fluorescing coating (phosphor) transforms some of the UV energy generated by the discharge into light.

Flush-mounted or Recessed Luminaire – a luminaire that is mounted above the ceiling (or behind a wall or other surface) with the opening of the luminaire level with the surface.

Footcandle, fc – a unit of illuminance equal to 1 lm/ft².

Glare – the sensation produced by luminances within the visual field that are sufficiently greater than the luminance to which the eyes are adapted, which causes annoyance, discomfort, or loss in visual performance, and visibility.

Globe – a transparent or diffusing enclosure intended to protect a lamp, to diffuse and redirect its light, or to change the color of the light.

High-Intensity discharge (HID) Lamp – an electric-discharge lamp in which the light-producing arc is stabilized by bulb wall temperature, and the arc tube has a bulb wall loading in excess of 3 W/cm². HID lamps include groups of lamps known as mercury, metal halide, and high pressure sodium.

High-Mast Lighting – illumination of a large area by means of a group of luminaires that are designed to be mounted in a fixed orientation at the top of a high mast,

generally 20 m (65 ft.) or higher.

High-Pressure sodium (HPS) lamp – a high intensity discharge (HID) lamp in which light is produced by radiation from sodium vapor.

Illuminance – the areal density of the luminous flux incident at a point on a surface.

Illuminance (footcandle or lux) meter – an instrument for measuring illuminance on a plane. The instrument is comprised of some form of photodetector with or without a filter driving a digital or analog readout through appropriate circuitry.

Illumination – an alternative but deprecated term for illuminance.

Incandescent filament lamp – a lamp in which light is produced by a filament heated to incandescence by an electric current.

Indirect Component – the portion of the luminous flux from a luminaire that arrives at the workplane after being reflected by room surfaces.

Indirect lighting – lighting involving luminaires that distribute 90 to 100% of the emitted light upward.

Induction lighting – lighting technology that uses electric current to induce an electromagnetic field within the phosphor coated lamp. No filaments are used. Its advantages include instant on/off operation, white light with good color rendering characteristics, and a long lamp life of 100,000 hours.

Instant-start fluorescent lamp – a fluorescent lamp designed for starting by a high voltage without preheating of the electrodes.

Intensity (candlepower) distribution curve – a curve, often polar, that represents the variation of luminous intensity of a lamp or luminaire in the plane through the light center.

Isolux (Isofootcandle) line – a line plotted on any appropriate set of coordinates to show all the points on a surface where the illuminance is the same.

Kelvin – the unit of temperature used to designate the color temperature of a light source.

Lamp – a generic term for a source created to produce optical radiation.

Lamp Lumen Depreciation (LLD) Factor – the fractional loss of lamp lumens at rated operating conditions that progressively occurs during lamp operation.

Lens – a glass or plastic element used in luminaires to change the direction and control the distribution of light rays.

Light – radiant energy that is capable of exciting the retina and producing a visual sensation.

Light-Emitting Diode (LED) - a p-n junction solid state diode whose radiated output is a function of its physical construction, material used, and exciting current.

Light Loss Factor (LLF) – formerly called maintenance factor. The ratio of illuminance (or exitance or luminance) for a given area to the value that would occur if lamps

operated at their (initial) rated lumens and if no system variation or depreciation had occurred.

Light Meter – a common name for an illuminance meter.

Light Source Color – the color of the light emitted by a source.

Louver – a series of baffles used to shield a source from view at certain angles, to absorb or block unwanted light, or to reflect or redirect light.

Low-Bay Lighting – interior lighting where the roof trusses or ceiling height is approximately 7.6 m (25 ft.) or less above the floor.

Low-Pressure Mercury Vapor Lamp – a discharge lamp (with or without a phosphor coating) in which the partial pressure of mercury vapor does not exceed 100 Pa during operation.

Low-Pressure Sodium (LPS) Lamp – a discharge lamp in which light is produced by radiation from sodium vapor.

Lumen, lm – SI unit of luminous flux.

Lumen Depreciation – the decrease in lumen output that occurs as a lamp is operated, until failure.

Lumen (or flux) Method – a lighting design procedure used for predetermining the relation between the number and types of lamps or luminaires, the room characteristics, and the average illuminance on the workplane.

Luminaire (light fixture) – a complete lighting unit consisting of a lamp or lamps and ballast(s) (when applicable) together with the parts designed to distribute the light, to position and protect the lamps, and to connect the lamps to the power supply.

Luminaire Dirt Depreciation (LDD) – the fractional loss of task illuminance due to luminaire dirt accumulation.

Luminaire Efficiency – the ratio of luminous flux (lumens) emitted by a luminaire to that emitted by the lamp or lamps used therein.

Luminance Contrast – the relationship between the luminances of an object and its immediate background.

Luminance ratio – the ratio between the luminances any two areas in the visual field.

Luminous Efficacy of a Source of Light – the quotient of the total luminous flux emitted to the total lamp power input. It is expressed in lumens per watt.

Matte Surface – a surface from which the reflection is predominantly diffuse, with or without a negligible specular component.

Means of Egress - an unobstructed and continuous way of exit from any point in a building or structure to a public way.

Mercury Lamp - a high-intensity discharge (HID) lamp in which the major portion of the light is produced by radiation from mercury operating at a partial pressure in excess of 10s Pa.

Mesopic Vision – vision with fully adapted eyes at luminance conditions between those of photopic and scotopic vision, that is, between about 3.4 and 0.034 cd/nr.

Metal Halide Lamp – a high-intensity discharge (HID) lamp in which the major portion of the light is produced by radiation of metal halides and their products of dissociation - possibly in combination with metallic vapors such as mercury.

Orientation – the relation of a building with respect to compass directions.

Overcast Sky – one that has 100% cloud cover; the sun is not visible.

Overhang – the distance between a vertical line passing through a specified point (often the photometric center) of a luminaire and the curb or edge of a roadway.

PAR Lamp – See pressed reflector lamp.

Partly Cloudy Sky – a sky that has 30 to 70% cloud cover.

Pendant luminaire – See suspended luminaire.

Peripheral Vision – the seeing of objects displaced from the primary line of sight and outside the central visual field.

Photometry – the measurement of quantities associated with light.

Photopic Vision – vision mediated essentially or exclusively by the cones. It is generally associated with adaptation to a luminance of at least 3.4 cd/m².

Point-by-Point Method – a method of lighting calculation, now called the point method.

Point Method – a lighting design procedure for predetermining the illuminance at various location in lighting installations by use of luminaire photometric data.

Point Source – a source of radiation, whose dimensions are sufficiently small, compared with the distance between the source and the irradiated surface, that these dimensions can be neglected in calculations and measurements.

Pole (roadway lighting) – a standard support generally used where overhead lighting distribution circuits are employed.

Programmed Rapid Start – a fluorescent starting method where the cathode is preheated before the lamp is ignited. This softer ignition increases the number of starts over the life of the lamp.

Quality of Lighting – pertains to the distribution of luminance in a visual environment. The term is used in a positive sense and implies that all luminances contribute favorably to visual performance, visual comfort, ease of seeing, safety, and aesthetics for the specific visual tasks involved.

Rapid-Start Fluorescent Lamp – a fluorescent lamp designed for operation with a ballast that provides a low-voltage winding for preheating the electrodes and initiating the arc without a starting switch or the application of high voltage.

Rated Lamp Life – the life value assigned to a particular type lamp. This is commonly a statistically determined estimate of average or of median operational life.

Reflected Glare – glare resulting from reflections of high luminances in polished or

glossy surfaces in the field of view.

Reflection – a general term for the process by which the incident flux leaves a (stationary) surface or medium from the incident side without change in frequency.

Reflector – a device used to redirect the flux from a source by the process of reflection.

Scotopic Vision – vision mediated essentially or exclusively by the rods. It is generally associated with adaptation to a luminance below about 0.034 cd/m².

Self-Ballasted Lamps – any arc discharge lamp of which the current limiting devices is an integral part.

Spacing – for roadway lighting, the distance between successive lighting units, measured along the centerline of the street.

Spacing-to-Mounting-Height Ratio – the ratio of the actual distance between luminaire centers to the mounting height above the work plane.

Sun Bearing – the angle measured in the plane of the horizon between a vertical plane at a right angle to the window wall and the position of this plane after it has been rotated to contain the sun.

Suspended (pendant) Luminaire – a luminaire that is hung from a ceiling by supports.

Table Lamp – a portable luminaire with a short stand, suitable for standing on furniture.

Torchiere – an indirect floor lamp that sends all or nearly all of its light upward.

Translucent – transmitting light diffusely or imperfectly.

Transmission – a general term for the process by which incident flux leaves a surface or medium on a side other than the incident side, without change in frequency.

Transmittance – the ratio of the transmitted flux to the incident flux.

Transmittance, Visible (T_{vis}) – the percentage of the visible spectrum transmitted.

Transparent – having the property of transmitting rays of light through its substance so that bodies situated beyond or behind can be distinctly seen.

Troffer – a long recessed lighting unit usually installed with the opening flush with the ceiling.

Tungsten-Halogen Lamp – a gas-filled tungsten filament incandescent lamp containing a certain proportion of halogens in an inert gas whose pressure exceeds 3 atm.

Valance – a longitudinal shielding member mounted across the top of a window or along a wall (and is usually parallel to the wall) to conceal light sources, giving both upward and downward distributions.

Valance Lighting – lighting comprising light sources shielded by a panel parallel to the wall at the top of a window.

Veiling Reflection – regular reflections that are superimposed upon diffuse reflections from an object that partially or totally obscure the details to be seen by reducing the contrast.

Visibility – the quality or state of being perceivable by the eye.

Volt – the difference in electrical potential between two points in a circuit.

Watt – the unit of power (rate of doing work). In electrical calculation, one watt is the power produced by a current of one ampere across a potential difference of one volt.

Workplane – the plane on which a visual task is usually done, and on which the illuminance is specified and measured.

APPENDIX D

Economic Analysis of Parking Lighting Example

D-1 The following spreadsheet shows all of the values assumed for the economic example shown on page 7-4.

Annual Operating Hours =	4380 (12 hours per day average)
Analysis Period =	10 years
Electric Energy =	\$0.06 per kWh
HPS Luminaire Cost =	\$1,500.00
HPS lamp cost =	\$20.00
HPS ballast cost =	\$50.00
MH Luminaire Cost =	\$1,500.00
MH lamp cost =	\$30.00
MH ballast cost =	\$50.00
IND Luminaire Cost =	\$1,500.00
Induction lamp & power supply cost =	\$350.00

Equipment Cost

Light Type	Luminaire Quantity	Equipment Cost	Total Cost
High Pressure Sodium	16	\$1,570	\$25,120
Metal Halide	16	\$1,580	\$25,280
Induction	16	\$1,850	\$29,600

Energy Cost

Light Type	Luminaire Quantity	Input Watts	Annual kWh	Annual Energy Cost	Energy Cost for Analysis Period	Annual Savings
250 watt High Pressure Sodium	16	295	20673.6	\$1,240	\$12,404	
150 watt Metal Halide	16	185	12965	\$778	\$7,779	\$4,625
165 watt Induction	16	165	11563.2	\$694	\$6,938	\$5,466

Lamp Replacement

Light Type	Luminaire Quantity	Lamp Life (hours)	Group relamp factor	Effective Life (hours)	group relampings in analysis period	# lamps replaced in analysis period	Lamp Cost (each)	Labor Cost (each lamp)*	Lamp repl. Cost for analysis period	Average Annual Savings
High Pressure Sodium	16	24000	0.7	16800	2	32	\$20.00	\$50.00	\$2,240	
Metal Halide	16	10000	0.7	7000	6	96	\$30.00	\$50.00	\$7,680	-\$5,440
Induction	16	100000	0.7	70000	0	0	\$350.00	\$50.00	\$0	\$2,240

Summary of Total Cost for Analysis Period

Light Type	Luminaire Quantity	Equipment	Energy	Replacement	Total Cost for Analysis Period	Savings for Analysis Period	Average Annual Savings
High Pressure Sodium	16	\$25,120	\$12,404	\$2,240	\$39,764		
Metal Halide	16	\$25,280	\$7,779	\$7,680	\$40,739	-\$975	-\$97
Induction	16	\$29,600	\$6,938	\$0	\$36,538	\$3,226	\$323

* Assumed Labor Cost: \$50 per lamp