



**NONRESIDENT
TRAINING
COURSE**

November 1996



Steelworker, Volume 2

NAVEDTRA 14251

Although the words “he,” “him,” and “his” are used sparingly in this course to enhance communication, they are not intended to be gender driven or to affront or discriminate against anyone.

COMMANDING OFFICER
NETPDTIC
6490 SAUFLEY FIELD RD
PENSACOLA, FL 32509-5237

ERRATA #1

29 May 2001

Specific Instructions and Errata for
Nonresident Training Course

STEELWORKER, VOLUME 2, NAVEDTRA 14251

1. This errata supersedes all previous errata. No attempt has been made to issue corrections for errors in typing, punctuation, etc., that do not affect your ability to answer the question or questions.
2. To receive credit for deleted questions, show this errata to your local course administrator (ESO/scorer). The local course administrator is directed to correct the course and the answer key by indicating the questions deleted.
3. Assignment Booklet, NAVEDTRA 14251.

Delete the following questions, and leave the corresponding spaces blank on the answer sheets:

Questions

2-44
3-16
3-17
3-18
4-45
4-52
4-55

Questions

5-12
6-31
7-23
7-55
8-51
8-52

PREFACE

By enrolling in this self-study course, you have demonstrated a desire to improve yourself and the Navy. Remember, however, this self-study course is only one part of the total Navy training program. Practical experience, schools, selected reading, and your desire to succeed are also necessary to successfully round out a fully meaningful training program.

COURSE OVERVIEW: In completing this nonresident training course, you will demonstrate a knowledge of the subject matter by correctly answering questions on the following subjects:

- Technical Administration
- Layout and Fabrication of Sheet Metal and Fiberglass Duct
- Structural Terms/Layout and Fabrication of Structural Steel and Pipe
- Fiber Line
- Wire Rope
- Rigging
- Reinforcing Steel
- Pre-engineered Structures: Buildings, K-Spans, Towers, and Antennas
- Pre-engineered Storage Tanks
- Pontoons
- Pre-engineered Structures: Short Airfield for Tactical Support
- Steelworker Tools and Equipment

THE COURSE: This self-study course is organized into subject matter areas, each containing learning objectives to help you determine what you should learn along with text and illustrations to help you understand the information. The subject matter reflects day-to-day requirements and experiences of personnel in the rating or skill area. It also reflects guidance provided by Enlisted Community Managers (ECMs) and other senior personnel, technical references, instructions, etc., and either the occupational or naval standards, which are listed in the *Manual of Navy Enlisted Manpower Personnel Classifications and Occupational Standards*, NAVPERS 18068.

THE QUESTIONS: The questions that appear in this course are designed to help you understand the material in the text.

VALUE: In completing this course, you will improve your military and professional knowledge. Importantly, it can also help you study for the Navy-wide advancement in rate examination. If you are studying and discover a reference in the text to another publication for further information, look it up.

*1996 Edition Prepared by
SWC Michael P. DePumpo*

Published by
NAVAL EDUCATION AND TRAINING
PROFESSIONAL DEVELOPMENT
AND TECHNOLOGY CENTER

**NAVSUP Logistics Tracking Number
0504-LP-026-8850**

Sailor's Creed

“I am a United States Sailor.

I will support and defend the Constitution of the United States of America and I will obey the orders of those appointed over me.

I represent the fighting spirit of the Navy and those who have gone before me to defend freedom and democracy around the world.

I proudly serve my country's Navy combat team with honor, courage and commitment.

I am committed to excellence and the fair treatment of all.”

CONTENTS

CHAPTER	PAGE
1. Technical Administration	1-1
2. Layout and Fabrication of Sheet Metal and Fiber-glass Duct	2-1
3. Structural Steel Terms/Layout and Fabrication of Structural Steel and Pipe	3-1
4. Fiber Line,	4-1
5. Wire Rope	5-1
6. Rigging	6-1
7. Reinforcing Steel	7-1
8. Pre-engineered Structures: Buildings, K-Spans, Towers, and Antennas	8-1
9. Pre-engineered Storage Tanks	9-1
10. Pontoons	10-1
11. Pre-engineered Structures: Short Airfield for Tactical support	11-1
12. Steelworker Tools and Equipment	12-1
APPENDIX	
I. Glossary	AI-1
II. Mathematics	AII-1
III. Metric Conversion Tables.	AIII-1
IV. Hand Signals	AIV-1
V. References Used to Develop This TRAMAN	AV-1
INDEX	INDEX-1

SAFETY PRECAUTIONS

Safety is a paramount concern for all personnel. Many of the Naval Ship's Technical manuals, manufacturer's technical manuals, and every Planned Maintenance System (PMS) maintenance requirement card (MRC) include safety precautions. Additionally, OPNAVINST 5100.19 (series), *Naval Occupational Safety and Health (NAVOSH) Program Manual for Forces Afloat*, and OPNAVINST 5100.23 (series), *NAVOSH Program Manual*, provide safety and occupational health information. The safety precautions are for your protection and to protect equipment.

During equipment operation and preventive or corrective maintenance, the procedures may call for personal protective equipment (PPE), such as goggles, gloves, safety shoes, hard hats, hearing protection, and respirators. When specified, your use of PPE is mandatory. You must select PPE appropriate for the job since the equipment is manufactured and approved for different levels of protection. If the procedure does not specify the PPE, and you aren't sure, ask your safety officer.

Most machinery, spaces, and tools requiring you to wear hearing protection are posted with hazardous noise signs or labels. Eye hazardous areas requiring you to wear goggles or safety glasses are also posted. In areas where corrosive chemicals are mixed or used, an emergency eyewash station must be installed.

All lubricating agents, oil, cleaning material, and chemicals used in maintenance and repair are hazardous materials. Examples of hazardous materials are gasoline, coal distillates, and asphalt. Gasoline contains a small amount of lead and other toxic compounds. Ingestion of gasoline can cause lead poisoning. Coal distillates, such as benzene or naphthalene in benzol, are suspected carcinogens. Avoid all skin contact and do not inhale the vapors and gases from these distillates. Asphalt contains components suspected of causing cancer. Anyone handling asphalt must be trained to handle it in a safe manner.

Hazardous materials require careful handling, storage, and disposal. PMS documentation provides hazard warnings or refers the maintenance man to the Hazardous Materials User's Guide. Material Safety Data Sheets (MSDS) also provide safety precautions for hazardous materials. All commands are required to have an MSDS for each hazardous material they have in their inventory. You must be familiar with the dangers associated with the hazardous materials you use in your work. Additional information is available from you command's *Hazardous Material Coordinator*. OPNAVINST 4110.2 (series), *Hazardous Material Control and Management*, contains detailed information on the hazardous material program.

Recent legislation and updated Navy directives implemented tighter constraints on environmental pollution and hazardous waste disposal. OPNAVINST 5090.1 (series), *Environmental and Natural Resources Program Manual*, provides detailed information. Your command must comply with federal, state, and local environmental regulations during any type of construction and demolition. Your supervisor will provide training on environmental compliance.

Cautions and warnings of potentially hazardous situations or conditions are highlighted, where needed, in each chapter of this TRAMAN. Remember to be safety conscious at all times.

SUMMARY OF STEELWORKER TRAINING MANUALS

VOLUME 1

Steelworker, Volume 1, NAVEDTRA 14250, consists of chapters on the following subjects: properties and Uses of Metal; Basic Heat Treatment; Introduction to Welding; Gas Cutting; Gas Welding; Soldering Brazing, Braze Welding and Wearfacing; Shielded Metal-Arc Welding and Wearfacing; and Gas Shielded-Arc Welding.

VOLUME 2

Steelworker, Volume 2, NAVEDTRA 14251, consists of chapters on the following subjects: Technical Administration; Layout and Fabrication of Sheet Metal and Fiber-Glass Duct; Structural Steel Terms/Layout and Fabrication of Structural Steel and Pipe; Fiber Line; Wire Rope; Rigging; Reinforcing Steel; Pre-engineered Structures: Buildings, K-Spans, Towers, and Antennas; Pre-engineered Storage Tanks; Pontoons; pre-engineered Structures: Short Airfield for Tactical Support; and Steelworker Tools and Equipment.

CREDITS

The following copyrighted illustrations in this TRAMAN are included through the courtesy of MIC Industries:

Figure 8-11

Figure 8-24

Figure 8-25

INSTRUCTIONS FOR TAKING THE COURSE

ASSIGNMENTS

The text pages that you are to study are listed at the beginning of each assignment. Study these pages carefully before attempting to answer the questions. Pay close attention to tables and illustrations and read the learning objectives. The learning objectives state what you should be able to do after studying the material. Answering the questions correctly helps you accomplish the objectives.

SELECTING YOUR ANSWERS

Read each question carefully, then select the BEST answer. You may refer freely to the text. The answers must be the result of your own work and decisions. You are prohibited from referring to or copying the answers of others and from giving answers to anyone else taking the course.

SUBMITTING YOUR ASSIGNMENTS

To have your assignments graded, you must be enrolled in the course with the Nonresident Training Course Administration Branch at the Naval Education and Training Professional Development and Technology Center (NETPDTC). Following enrollment, there are two ways of having your assignments graded: (1) use the Internet to submit your assignments as you complete them, or (2) send all the assignments at one time by mail to NETPDTC.

Grading on the Internet: Advantages to Internet grading are:

- you may submit your answers as soon as you complete an assignment, and
- you get your results faster; usually by the next working day (approximately 24 hours).

In addition to receiving grade results for each assignment, you will receive course completion confirmation once you have completed all the

assignments. To submit your assignment answers via the Internet, go to:

<http://courses.cnet.navy.mil>

Grading by Mail: When you submit answer sheets by mail, send all of your assignments at one time. Do NOT submit individual answer sheets for grading. Mail all of your assignments in an envelope, which you either provide yourself or obtain from your nearest Educational Services Officer (ESO). Submit answer sheets to:

COMMANDING OFFICER
NETPDTC N331
6490 SAUFLEY FIELD ROAD
PENSACOLA FL 32559-5000

Answer Sheets: All courses include one “scannable” answer sheet for each assignment. These answer sheets are preprinted with your SSN, name, assignment number, and course number. Explanations for completing the answer sheets are on the answer sheet.

Do not use answer sheet reproductions: Use only the original answer sheets that we provide—reproductions will not work with our scanning equipment and cannot be processed.

Follow the instructions for marking your answers on the answer sheet. Be sure that blocks 1, 2, and 3 are filled in correctly. This information is necessary for your course to be properly processed and for you to receive credit for your work.

COMPLETION TIME

Courses must be completed within 12 months from the date of enrollment. This includes time required to resubmit failed assignments.

PASS/FAIL ASSIGNMENT PROCEDURES

If your overall course score is 3.2 or higher, you will pass the course and will not be required to resubmit assignments. Once your assignments have been graded you will receive course completion confirmation.

If you receive less than a 3.2 on any assignment and your overall course score is below 3.2, you will be given the opportunity to resubmit failed assignments. **You may resubmit failed assignments only once.** Internet students will receive notification when they have failed an assignment--they may then resubmit failed assignments on the web site. Internet students may view and print results for failed assignments from the web site. Students who submit by mail will receive a failing result letter and a new answer sheet for resubmission of each failed assignment.

COMPLETION CONFIRMATION

After successfully completing this course, you will receive a letter of completion.

ERRATA

Errata are used to correct minor errors or delete obsolete information in a course. Errata may also be used to provide instructions to the student. If a course has an errata, it will be included as the first page(s) after the front cover. Errata for all courses can be accessed and viewed/downloaded at:

<http://www.advancement.cnet.navy.mil>

STUDENT FEEDBACK QUESTIONS

We value your suggestions, questions, and criticisms on our courses. If you would like to communicate with us regarding this course, we encourage you, if possible, to use e-mail. If you write or fax, please use a copy of the Student Comment form that follows this page.

For subject matter questions:

E-mail: n314.products@cnet.navy.mil
Phone: Comm: (850) 452-1001, Ext. 1826
DSN: 922-1001, Ext. 1826
FAX: (850) 452-1370
(Do not fax answer sheets.)
Address: COMMANDING OFFICER
NETPDTC N314
6490 SAUFLEY FIELD ROAD
PENSACOLA FL 32509-5237

For enrollment, shipping, grading, or completion letter questions

E-mail: fleetservices@cnet.navy.mil
Phone: Toll Free: 877-264-8583
Comm: (850) 452-1511/1181/1859
DSN: 922-1511/1181/1859
FAX: (850) 452-1370
(Do not fax answer sheets.)
Address: COMMANDING OFFICER
NETPDTC N331
6490 SAUFLEY FIELD ROAD
PENSACOLA FL 32559-5000

NAVAL RESERVE RETIREMENT CREDIT

If you are a member of the Naval Reserve, you may earn retirement points for successfully completing this course, if authorized under current directives governing retirement of Naval Reserve personnel. For Naval Reserve retirement, this course is evaluated at 12 points. (Refer to *Administrative Procedures for Naval Reservists on Inactive Duty*, BUPERSINST 1001.39, for more information about retirement points.)

Student Comments

Course Title: Steelworker, Volume 2

NAVEDTRA: 14251 **Date:** _____

We need some information about you:

Rate/Rank and Name: _____ SSN: _____ Command/Unit _____

Street Address: _____ City: _____ State/FPO: _____ Zip _____

Your comments, suggestions, etc.:

<p>Privacy Act Statement: Under authority of Title 5, USC 301, information regarding your military status is requested in processing your comments and in preparing a reply. This information will not be divulged without written authorization to anyone other than those within DOD for official use in determining performance.</p>
--

NETPDTC 1550/41 (Rev 4-00)











CHAPTER 3

STRUCTURAL STEEL TERMS / LAYOUT AND FABRICATION OF STEEL AND PIPE

Structural steel is one of the basic materials used in the construction of frames for most industrial buildings, bridges, and advanced base structures. Therefore, you, as a Seabee Steelworker, must have a thorough knowledge of various steel structural members. Additionally, it is necessary before any structural steel is fabricated or erected, a plan of action and sequence of events be set up. The plans, sequences, and required materials are predetermined by the engineering section of a unit and are then drawn up as a set of blueprints. This chapter describes the terminology applied to structural steel members, the use of these members, the methods by which they are connected, and the basic sequence of events which occurs during erection.

STRUCTURAL STEEL MEMBERS

Your work will require the use of various structural members made up of standard structural shapes manufactured in a wide variety of shapes of cross sections and sizes. Figure 3-1 shows many of these various shapes. The three most common types of structural members are the W-shape (wide flange), the S-shape (American Standard I-beam), and the C-shape (American Standard channel). These three types are identified by the nominal depth, in inches, along the web and the weight per foot of length, in pounds. As an example, a W 12 x 27 indicates a W-shape (wide flange) with a web 12 inches deep and a weight of 27 pounds per linear foot. Figure 3-2 shows the cross-sectional views of the W-, S-, and C-shapes. The difference between the W-shape and

OLD SYMBOL	OLD ILLUSTRATED USE	DESCRIPTION	EXAMPLE	NEW SYMBOL	NEW ILLUSTRATED USE
WF	24WF76	W-SHAPE (WIDE FLANGE)		W	W24 X 76
BP	14BP73	BEARING PILE		BP	BP14 X 73
I	15I 42.9	S-SHAPE (AMERICAN STD I-BEAM)		S	S15 X 42.9
C	9 C 13.4	C-SHAPE (AMERICAN STD CHANNEL)		C	C9 X 13.4
M	8 X 8M34.3	M-SHAPE (MISC SHAPES OTHER THAN W, BP, S, & C)		M	M8 X 34.3
M	8M17			M8 X 17	
Jr	Jr 7Jr.5.5			M7 X 5.5	
MC	12 X 4 MC 44.5	MC-SHAPE (CHANNELS OTHER THAN AMERICAN STD)		MC	MC12 X 45
Jr MC	10Jr MC 84			MC12 X 12.6	
L	L 3 X 3 X 1/4	ANGLES: EQUAL LEG		L	3 X 3 X 1/4
L	L 7 X 4 X 1/2	UN-EQUAL LEG		L	L 7 X 4 X 1/2
ST	ST5WF10.5	TEES, STRUCTURAL: CUT FROM W-SHAPE CUT FROM S-SHAPE CUT FROM M-SHAPE		WT ST MT	WT12 X 38 ST12 X 38 MT12 X 38
PL	PL 18 X 1/2 X 2'-6"	PLATE		PL	PL 1/2 X 18" X 30"
BAR	BAR 2 1/2 X 1/4	FLAT BAR		BAR	BAR 2 1/2 X 1/4
O	O 6φ	PIPE, STRUCTURAL			PIPE 4 STD PIPE 4X-STRG PIPE 4 XX-STRG

SVNPO504

Figure 3-1.—Structural shapes and designations.

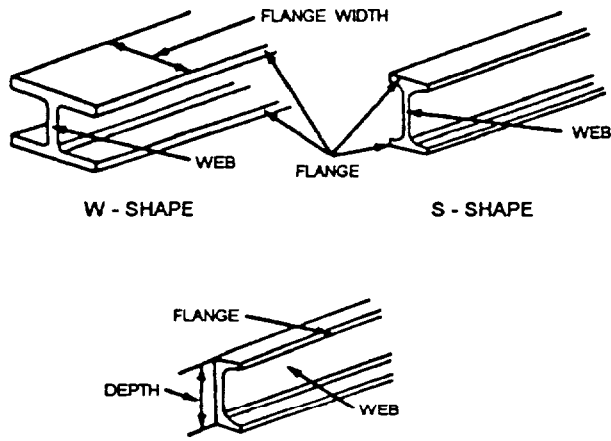

Figure 3-2.—Structural shapes.

the S-shape is in the design of the inner surfaces of the flange. The W-shape has parallel inner and outer flange surfaces with a constant thickness, while the S-shape has a slope of approximately 17' on the inner flange surfaces. The C-shape is similar to the S-shape in that its inner flange surface is also sloped approximately 17'.

The W-SHAPE is a structural member whose cross section forms the letter H and is the most widely used structural member. It is designed so that its flanges provide strength in a horizontal plane, while the web gives strength in a vertical plane. W-shapes are used as beams, columns, truss members, and in other load-bearing applications.

The BEARING PILE (HP-shape) is almost identical to the W-shape. The only difference is that the flange thickness and web thickness of the bearing pile are equal, whereas the W-shape has different web and flange thicknesses.

The S-SHAPE (American Standard I-beam) is distinguished by its cross section being shaped like the letter I. S-shapes are used less frequently than W-shapes since the S-shapes possess less strength and are less adaptable than W-shapes.

The C-SHAPE (American Standard channel) has a cross section somewhat similar to the letter C. It is especially useful in locations where a single flat face without outstanding flanges on one side is required. The C-shape is not very efficient for a beam or column when used alone. However, efficient built-up members may be constructed of channels assembled together with other structural shapes and connected by rivets or welds.

An ANGLE is a structural shape whose cross section resembles the letter L. Two types, as illustrated in figure 3-3, are commonly used: an equal-leg angle and an unequal-leg angle. The angle is identified by the dimension and thickness of its legs; for example, angle 6 inches x 4 inches x 1/2 inch. The dimension of the legs should be obtained by measuring along the outside of the backs of the legs. When an angle has unequal legs, the dimension of the wider leg is given first, as in the example just cited. The third dimension applies to the thickness of the legs, which always have equal thickness. Angles may be used in combinations of two or four to form main members. A single angle may also be used to connect main parts together.

Steel PLATE is a structural shape whose cross section is in the form of a flat rectangle. Generally, a main point to remember about plate is that it has a width of greater than 8 inches and a thickness of 1/4 inch or greater.

Plates are generally used as connections between other structural members or as component parts of built-up structural members. Plates cut to specific sizes may be obtained in widths ranging from 8 inches to 120 inches or more, and in various thicknesses. The edges of these plates may be cut by shears (sheared plates) or be rolled square (universal mill plates).

Plates frequently are referred to by their thickness and width in inches, as plate 1/2 inch x 24 inches. The length in all cases is given in inches. Note in figure 3-4 that 1 cubic foot of steel weighs 490 pounds. This weight divided by 12 gives you 40.8, which is the weight (in pounds) of a steel plate 1 foot square and 1 inch thick. The fractional portion is normally dropped and 1-inch plate is called a 40-pound plate. In practice, you may hear plate referred to by its approximate weight per square foot for a specified thickness. An example is 20-pound plate, which indicates a 1/2-inch plate. (See figure 3-4.)

The designations generally used for flat steel have been established by the American Iron and Steel Institute (AISI). Flat steel is designated as bar, strip,

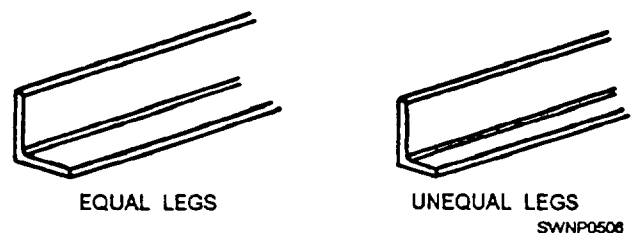

Figure 3-3.—Angles.

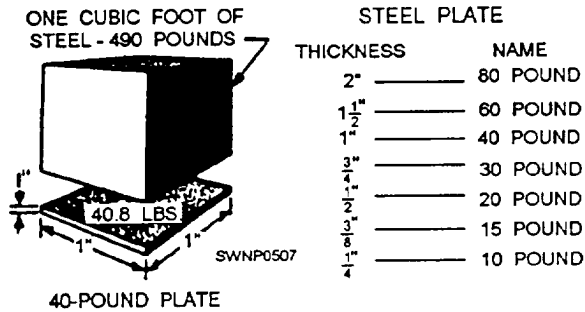

Figure 3-4.—Weight and thickness of steel plate.

sheet, or plate, according to the thickness of the material, the width of the material, and (to some extent) the rolling process to which it was subjected. Table 3-1 shows the designations usually used for hot-rolled carbon steels. These terms are somewhat flexible and in some cases may overlap.

The structural shape referred to as a BAR has a width of 8 inches or less and a thickness greater than 3/16 of an inch. The edges of bars usually are rolled square, like universal mill plates. The dimensions are expressed in a similar manner as that for plates; for instance, bar 6 inches x 1/2 inch. Bars are available in a variety of cross-sectional shapes—round, hexagonal, octagonal, square, and flat. Three different shapes are illustrated in figure 3-5. Both squares and rounds are commonly used as bracing members of light structures. Their dimensions, in inches, apply to the side of the square or the diameter of the round.

Now that you have been introduced to the various structural members used in steel construction, let us develop a theoretical building frame from where you, the Steelworker, would start on a project after all the earthwork and footings or slab have been completed. Remember this sequence is theoretical and may vary

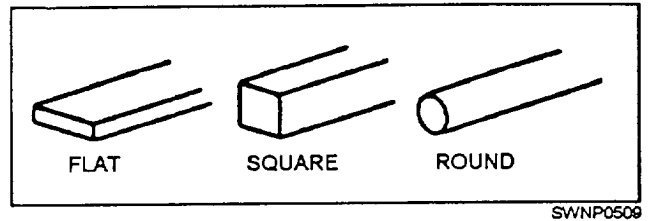

Figure 3-5.—Bars.

somewhat, depending on the type of structure being erected.

ANCHOR BOLTS

Anchor bolts (fig. 3-6) are cast into the concrete foundation. They are designed to hold the column bearing plates, which are the first members of a steel frame placed into position. These anchor bolts must be positioned very carefully so that the bearing plates will be lined up accurately.

BEARING PLATES

The column bearing plates are steel plates of various thicknesses in which holes have been either drilled or cut with an oxygas torch to receive the

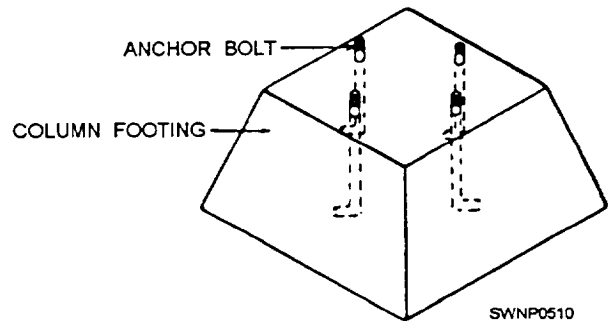

Figure 3-6.—Anchor bolts.

Table 3-1.—Plate, Bar, Strip, and Sheet designation

THICKNESS (Inches)	WIDTH (Inches)					
	TO 3 1/2 INCLUSIVE	OVER 3 1/2 TO 6	OVER 6 TO 8	OVER 8 TO 12	OVER 12 TO 48	OVER 48
0.2300 and THICKER	BAR				PLATE	
0.2299 and 0.2031	STRIP				SHEET	
0.2030 and 0.1800	STRIP				SHEET	
0.1799 and 0.0449	STRIP				SHEET	
0.0448 and 0.0344	STRIP				SHEET	
0.0343 and 0.0255	STRIP				SHEET	
0.0254 and THINNER	STRIP				SHEET	

SWNP0508

anchor bolts (fig. 3-7). The holes should be slightly larger than the bolts so that some lateral adjustment of the bearing plate is possible. The angle connections, by which the columns are attached to the bearing plates, are bolted or welded in place according to the size of the column, as shown in figure 3-8.

After the bearing plate has been placed into position, shim packs are set under the four corners of each bearing plate as each is installed over the anchor bolts, as shown in figure 3-9. The shim packs are 3- to 4-inch metal squares of a thickness ranging from 1 1/6 to 3/4 inch, which are used to bring all the bearing

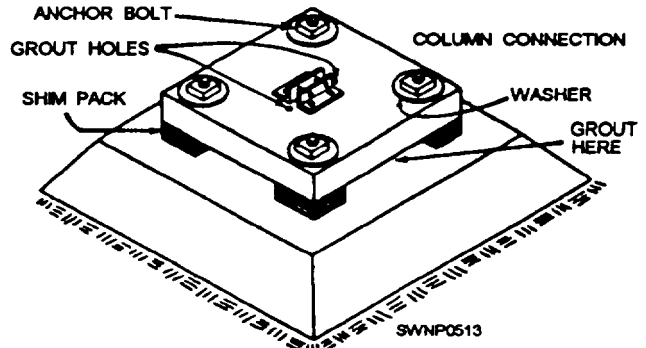

Figure 3-9.—Leveled bearing plate.

plates to the correct level and to level each bearing plate on its own base.

The bearing plates are first leveled individually by adjusting the thickness of the shim packs. This operation may be accomplished by using a 2-foot level around the top of the bearing plate perimeter and diagonally across the bearing plate.

Upon completion of the leveling operation, all bearing plates must be brought either up to or down to the grade level required by the structure being erected. All bearing plates must be lined up in all directions with each other. This may be accomplished by using a surveying instrument called a builder's level. String lines may be set up along the edges and tops of the bearing plates by spanning the bearing plates around the perimeter of the structure, making a grid network of string lines connecting all the bearing plates.

After all the bearing plates have been set and aligned, the space between the bearing plate and the top of the concrete footing or slab must be filled with a hard, nonshrinking, compact substance called GROUT. (See fig. 3-9.) When the grout has hardened the next step is the erection of the columns.

COLUMNS

Wide flange members, as nearly square in cross section as possible, are most often used for columns. Large diameter pipe is also used frequently (fig. 3-10), even though pipe columns often present connecting difficulties when you are attaching other members. Columns may also be fabricated by welding or bolting a number of other rolled shapes, usually angles and plates, as shown in figure 3-11.

If the structure is more than one story high, it may be necessary to splice one column member on top of another. If this is required, column lengths should be

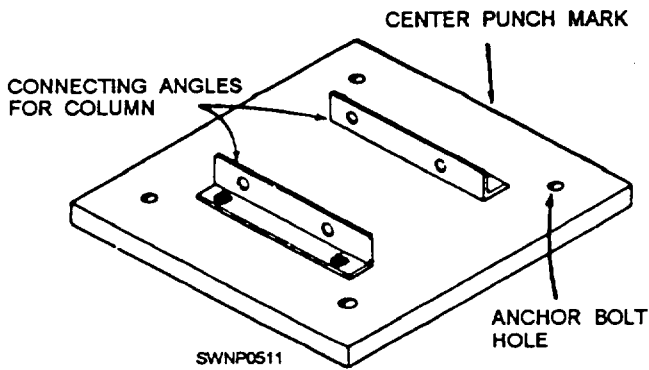

Figure 3-7.—Column bearing plate.

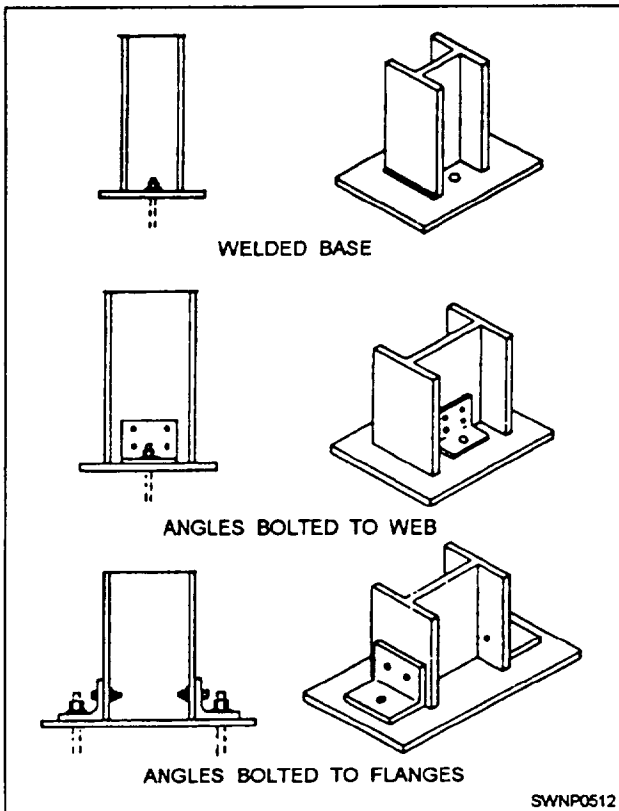

Figure 3-8.—Typical column to baseplate connections.

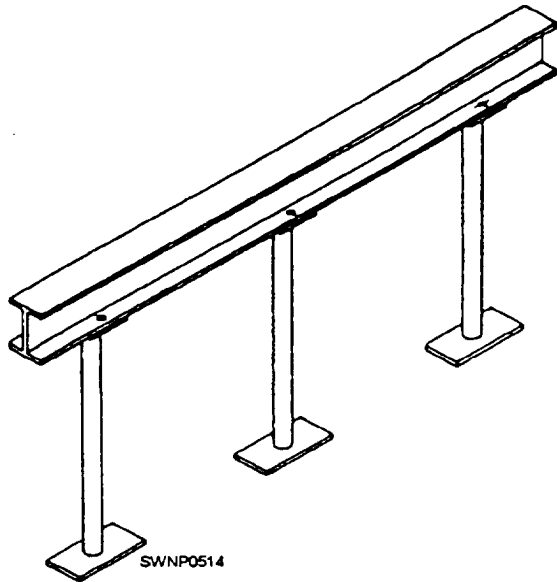

Figure 3-10.—Girder span on pipe columns.

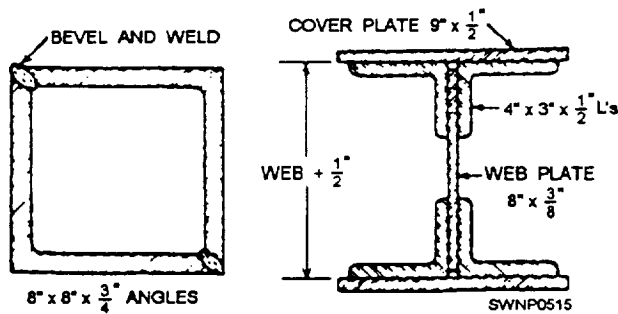

Figure 3-11.—Built-up column section.

such that the joints or splices are 1 1/2 to 2 feet above the second and succeeding story levels. This will ensure that the splice connections are situated well above the girder or beam connections so that they do not interfere with other second story work.

Column splices are joined together by splice plates which are bolted, riveted, or welded to the column flanges, or in special cases, to the webs as well. If the members are the same size, it is common practice to butt one end directly to the other and fasten the splice plates over the joint, as illustrated in figure 3-12. When the column size is reduced at the joint, a plate is used between the two ends to provide bearing, and filler plates are used between the splice plates and the smaller column flanges (fig. 3-13).

GIRDERS

Girders are the primary horizontal members of a steel frame structure. They span from column to

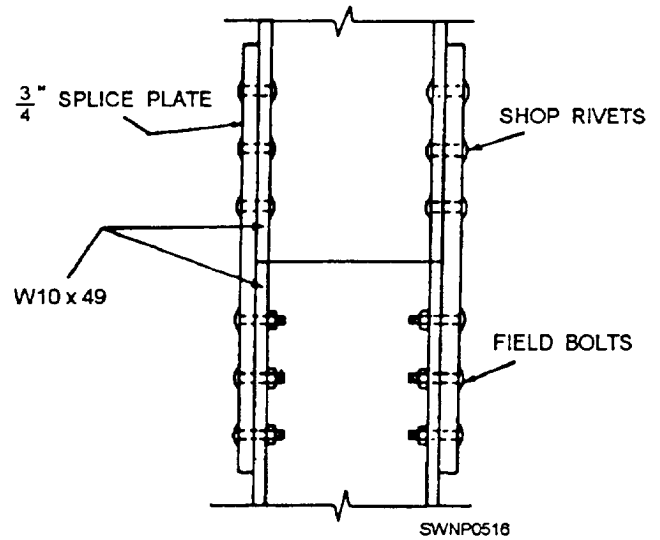

Figure 3-12.—Column splice with no size change.

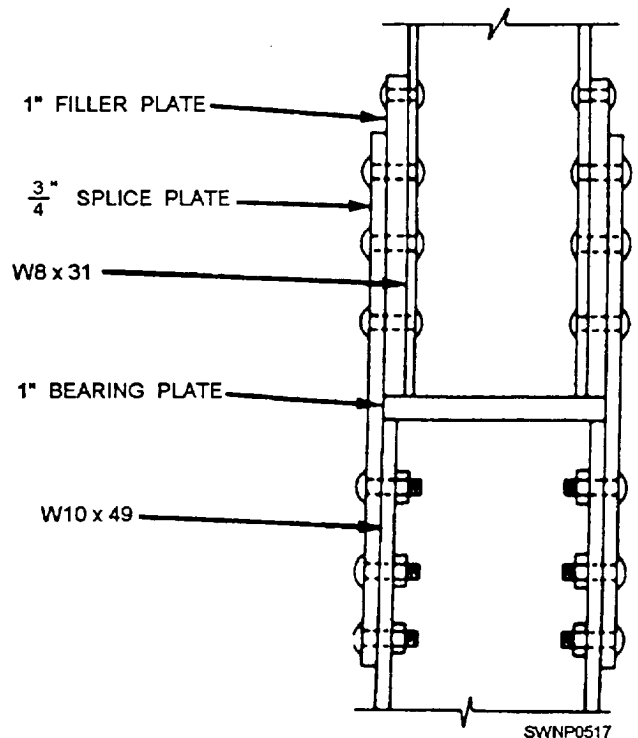

Figure 3-13.—Column splice with change in column size.

column and are usually connected on top of the columns with CAP PLATES (bearing connections), as shown in figure 3-14. An alternate method is the seated connection (fig. 3-15). The girder is attached to the flange of the column using angles, with one leg extended along the girder flange and the other against the column. The function of the girders is to support the intermediate floor beams.

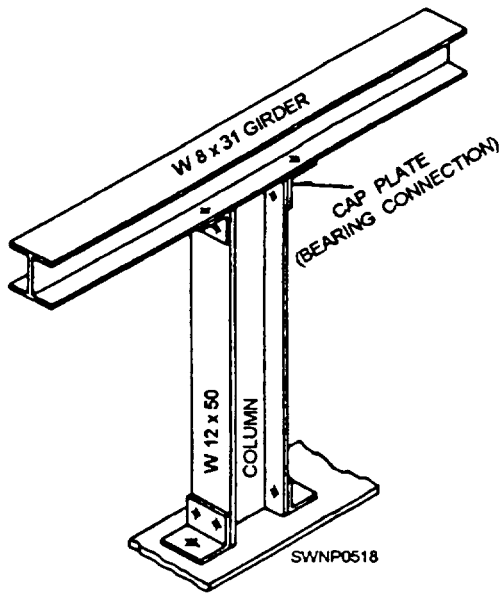

Figure 3-14.—Girder span on a wide flange column.

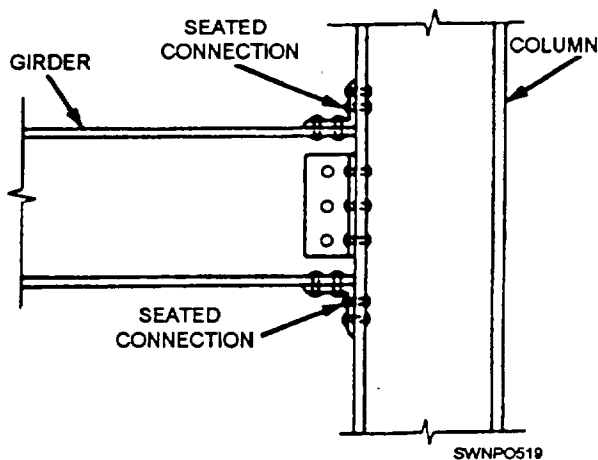

Figure 3-15.—Seated connections.

BEAMS

Beams are generally smaller than girders and are usually connected to girders as intermediate members or to columns. Beam connections at a column are similar to the seated girder-to-column connection. Beams are used generally to carry floor loads and transfer those loads to the girders as vertical loads. Since beams are usually not as deep as girders, there are several alternative methods of framing one into the other. The simplest method is to frame the beam between the top and bottom flanges on the girder, as shown in figure 3-16. If it is required that the top or bottom flanges of the girders and beams be flush, it is necessary to cut away (cope) a portion of the upper or lower beam flange, as illustrated in figure 3-17.

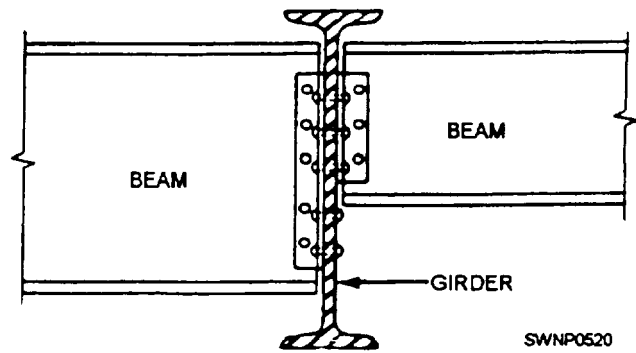

Figure 3-16.—Column splice with no size change

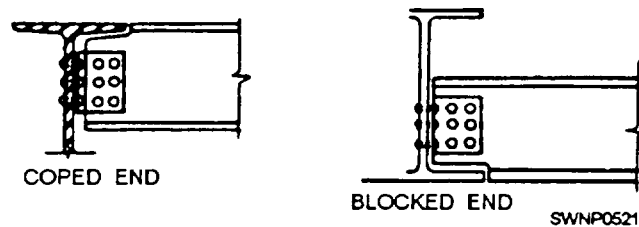

Figure 3-17.—Coped and blocked beam ends.

BAR JOIST

Bar joists form a lightweight, long-span system used as floor supports and built-up roofing supports, as shown in figure 3-18. Bar joists generally run in the same direction as a beam and may at times eliminate the need for beams. You will notice in figure 3-19 that bar joists must have a bearing surface. The span is from girder to girder. (See fig. 3-20.)

Prefabricated bar joists designed to conform to specific load requirements are obtainable from commercial companies.

TRUSSES

Steel trusses are similar to bar joists in that they serve the same purpose and look somewhat alike. They are, however, much heavier and are fabricated almost entirely from structural shapes, usually angles and T-shapes. (See fig. 3-21.) Unlike bar joists, trusses can be fabricated to conform to the shape of almost any roof system (fig. 3-22) and are therefore more versatile than bar joists.

The bearing surface of a truss is normally the column. The truss may span across the entire building from outside column to outside column. After the trusses have been erected, they must be secured between the BAYS with diagonal braces (normally

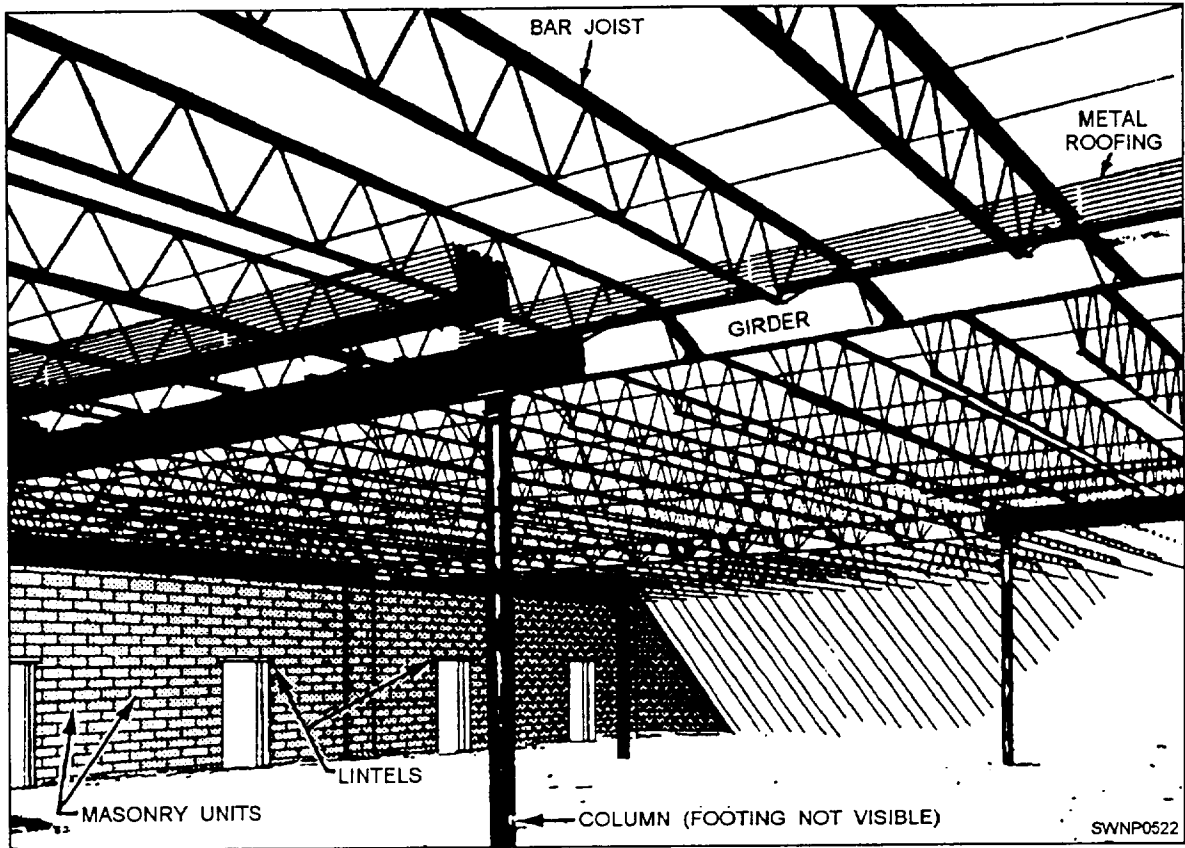

Figure 3-18.—Clearspan bar joists (girder to girder) ready to install roof sheeting.

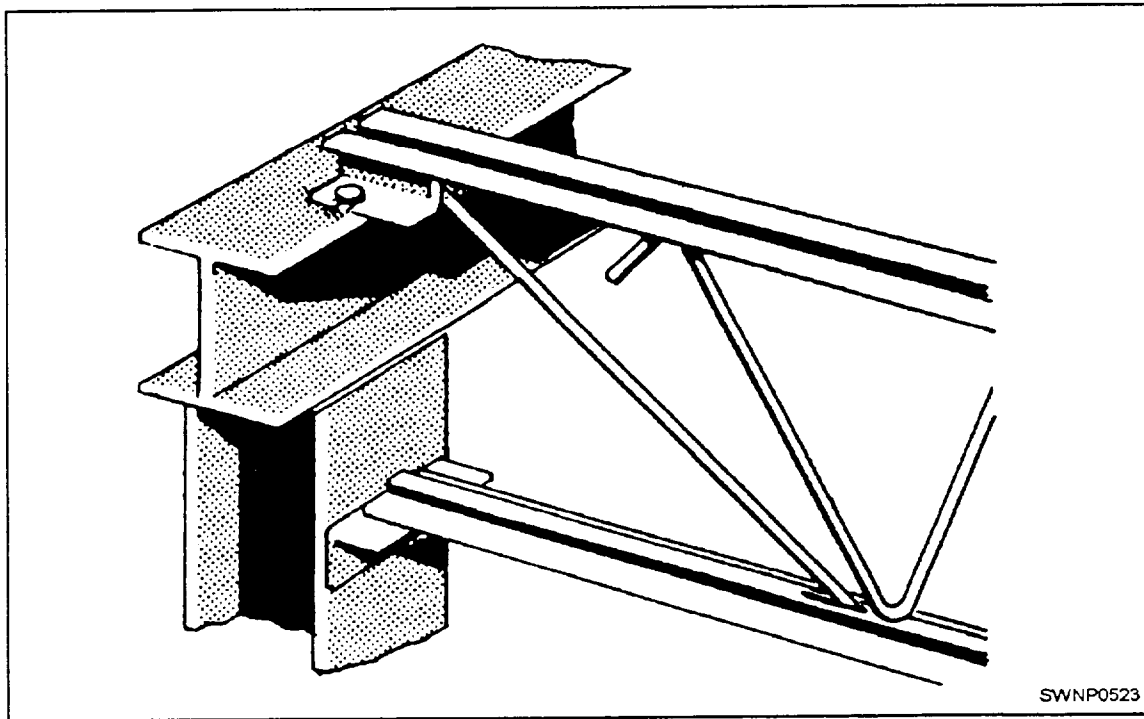

Figure 3-19.—Bar joists seat connection.

round rods or light angles) on the top chord plane (fig. 3-23) and the bottom chord plane (fig. 3-24). After these braces are installed, a sway frame is put into place. (See fig. 3-25.)

PURLINS, GIRTS, AND EAVE STRUTS

Purlins are generally lightweight and channel-shaped and are used to span roof trusses. Purlins receive the steel or other type of decking, as shown in figure 3-26, and are installed with the legs of the channel facing outward or down the slope of the roof. The purlins installed at the ridge of a gabled roof are referred to as RIDGE STRUTS. The purlin units are placed back to back at the ridge and tied together with steel plates or threaded rods, as illustrated in figure 3-27.

The sides of a structure are often framed with girts. These members are attached to the columns horizontally (fig. 3-28). The girts are also channels, generally the same size and shape as roof purlins. Siding material is attached directly to the girts.

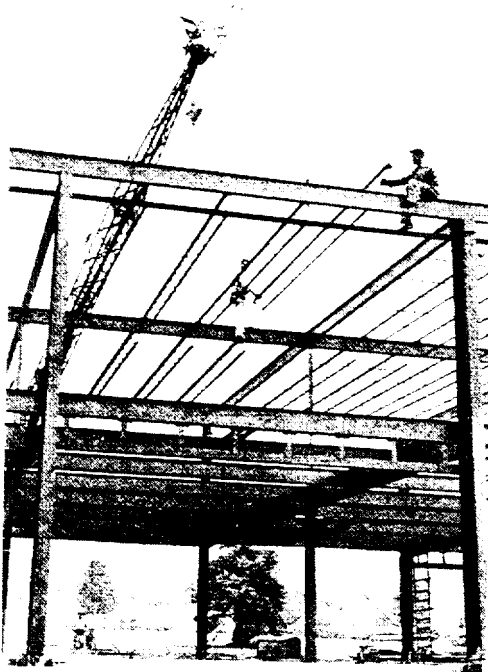

Figure 3-20.—Installing bar Joists girder to girder.

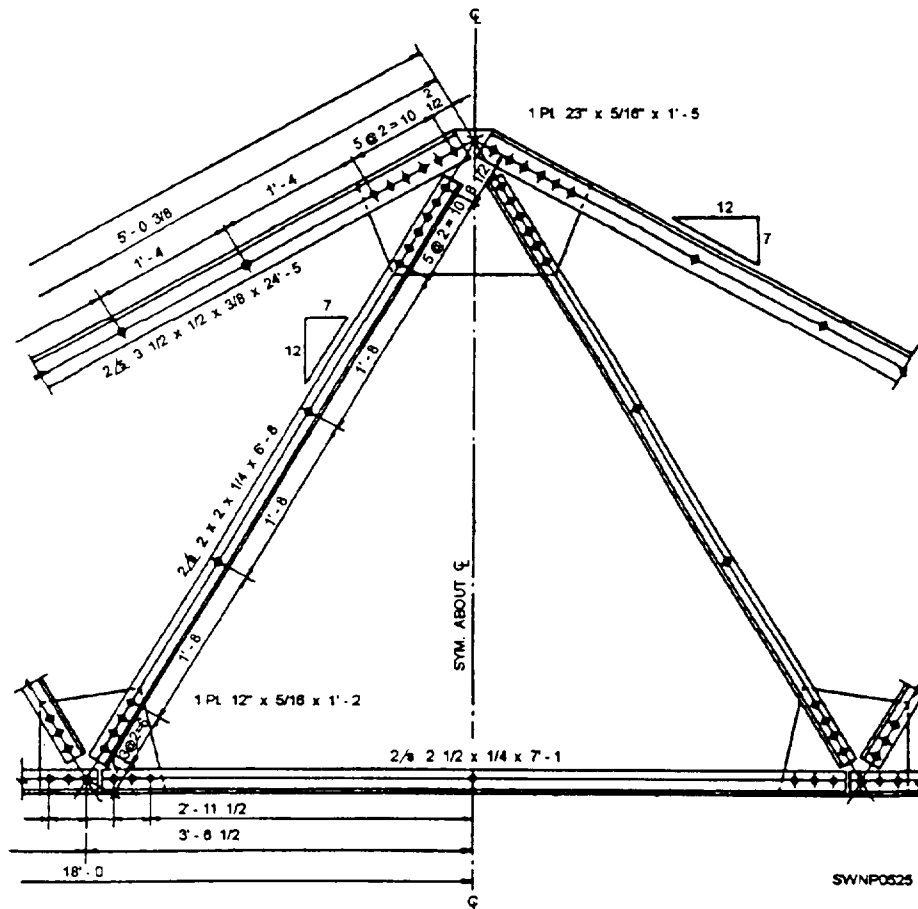

Figure 3-21.—Steel truss fabricated from angle-shaped members.

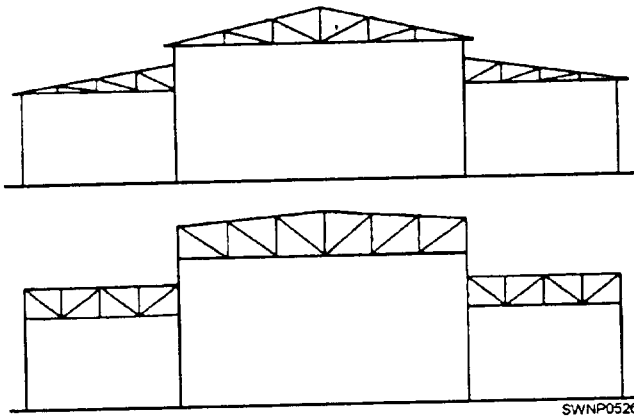

Figure 3-22.—Different styles of truss shapes.

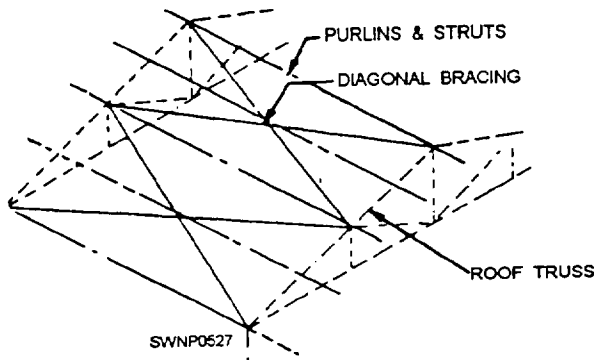

Figure 3-23.—Diagonal braces-top chord plane.

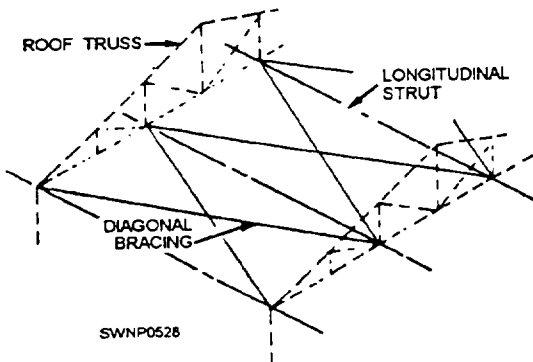

Figure 3-24.—Diagonal braces-bottom chord plane.

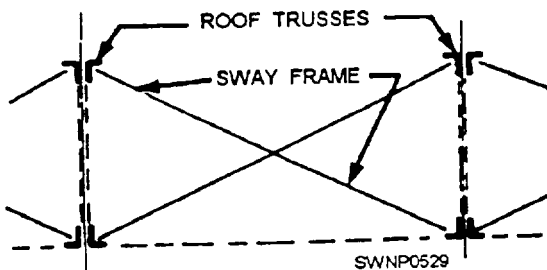

Figure 3-25.—Sway frame.

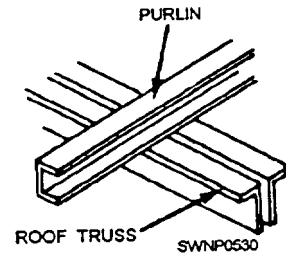

Figure 3-26.—Roof purlin.

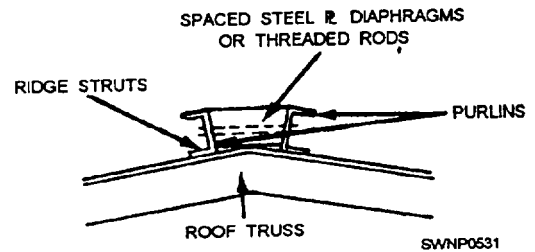

Figure 3-27.—Ridge struts.

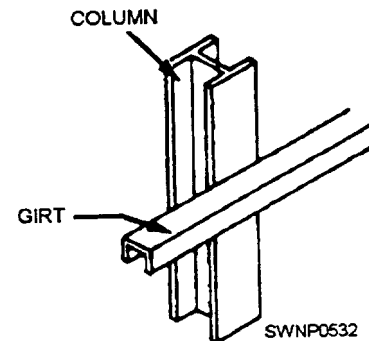

Figure 3-28.—Wall girt.

Another longitudinal member similar to purlins and girts is an eave strut. This member is attached to the column at the point where the top chord of a truss and the column meet at the eave of the structure. (See fig. 3-29.)

There are many more steelworking terms that you will come across as you gain experience. If a term is

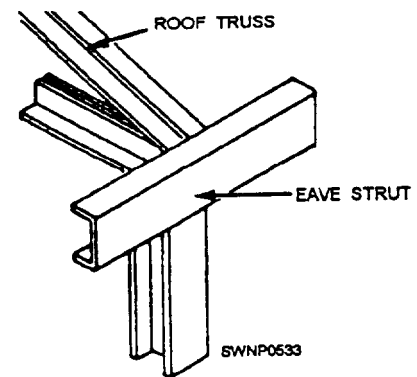

Figure 3-29.—Eave strut.

used that you do not understand, ask someone to explain it or look it up in the manuals and publications available to you.

Steelworkers are required to lay out and fabricate steel plate and structural steel members. Assignments you can expect to be tasked with include pipe layout and fabrication projects of the type required on a tank farm project. Plate layout procedures are similar to those for sheet metal (see chapter 2). There are some procedures of plate fabrication however, that are fundamentally different, and they are described in this chapter. Steelworkers are also tasked to construct and install piping systems designed to carry large quantities of liquids for long distances.

FABRICATING PLATE AND STRUCTURAL MEMBERS

Steel plate is much thicker than sheet steel and is more difficult to work with and form into the desired shapes. Before fabricating anything with steel, you must take into consideration certain factors and ensure they have been planned for. First, ensure adequate lighting is available to enable you to see the small marks you will be scratching on the steel. Second, ensure all tools you need are available and accessible at the work area. Also, ensure you have an accurate field sketch or shop drawing of the item to be fabricated.

LAYOUT OF STEEL PLATE

When laying out steel plate, you should have the following tools: an adequate scale, such as a combination square with a square head, an accurate protractor, a set of dividers, a prick punch, a center punch, and a ball peen hammer.

When layout marks are made on steel, you must use a wire brush to clean them and remove the residue with a brush or rag. Then paint the surface with a colored marking compound. Aerosol spray is very good because it allows the paint to fall only in the areas to be laid out and also because it produces a thin coat of paint that will not chip or peel off when lines are being scribed.

When appropriate, the layout lines can be drawn on steel with a soapstone marker or a similar device. However, remember that the markings of many of these drawing devices can burn off under an oxygas flame as well or be blown away by the force of oxygen from the cutting torch. These conditions are undesirable and can ruin an entire fabrication job. If

using soapstone or a similar marker is your only option, be sure to use a punch and a ball peen hammer to make marks along the cut lines. By “connecting the dots,” you can ensure accuracy.

Plan material usage before starting the layout on a plate. An example of proper plate layout and material usage is shown in figure 3-30. Observe the material used for the cooling box. It will take up slightly more than half of the plate. The rest of the material can then be used for another job. This is only one example, but the idea is to conserve materials. An example of poor layout is shown in figure 3-31. The entire plate is used up for this one product, wasting material, increasing the cost and layout time of the job.

The layout person must have a straight line or straightedge that he or she refers all measurements to. This straightedge or line can be one edge of the work that has been finished straight; or it can be an outside straight line fastened to the work, such as a straightedge clamped to the work. Once the reference line has been established, you can proceed with the layout using the procedures described in chapter 2.

When the layout is complete, the work should be checked for accuracy, ensuring all the parts are in the

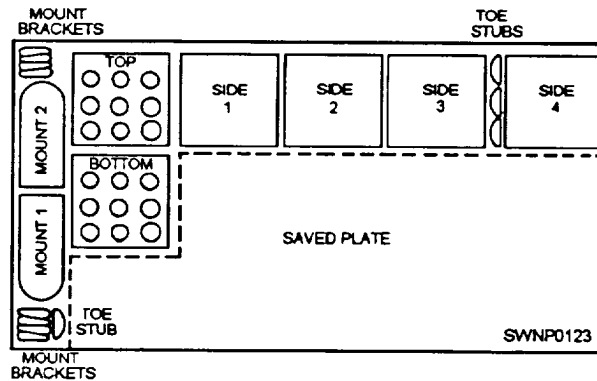

Figure 3-30.—Proper plate steel cooling box layout.

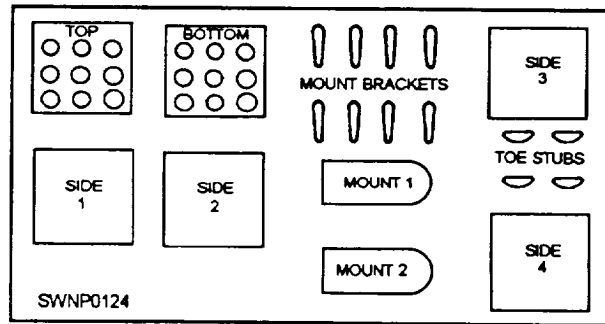

Figure 3-31.—Improper plate steel cooling box layout.

layout and the measurements are correct. After determining that the layout is accurate, the layout person should center punch all cutting lines. This ensures accurate cutting with either a torch or shears. The work can be checked after cutting because each piece will have one half of the center punch marks on the edge of the material. Remember, always cut with the kerf of the torch on the outside edge of the cutting lines.

LAYOUT OF STRUCTURAL SHAPES

Structural shapes are slightly more difficult to lay out than plate. This is because the layout lines may not be in view of the layout person at all times. Also, the reference line may not always be in view.

Steel beams are usually fabricated to fit up to another beam. Coping and slotting are required to accomplish this. Figure 3-32 shows two W 10 x 39 beams being fitted up. Beam A is intersecting beam B at the center. Coping is required so beam A will butt up to the web of beam B; the connecting angles can be welded to the web, and the flanges can be welded together.

A cut 1 1/8 inches (2.8 cm) long at 45 degrees at the end of the flange cope will allow the web to fit up under the flange of beam B and also allow for the fillet.

The size of the cope is determined by dividing the flange width of the receiving beam in half and then subtracting one half of the thickness of the web plus 1/16 inch. This determines how far back on beam A the cope should be cut.

When two beams of different sizes are connected, the layout on the intersecting beam is determined by whether it is larger or smaller than the intersected beam. In the case shown in figure 3-33, the

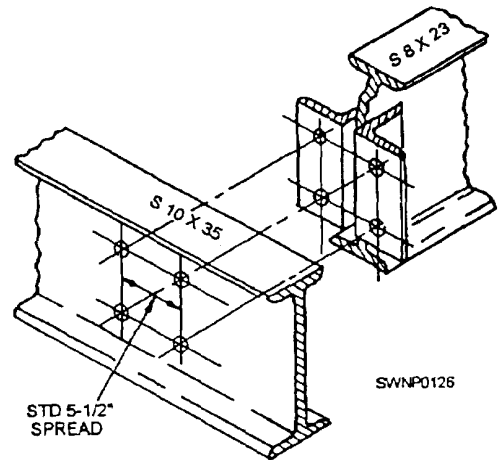

Figure 3-33.—Typical framed construction, top flange flush.

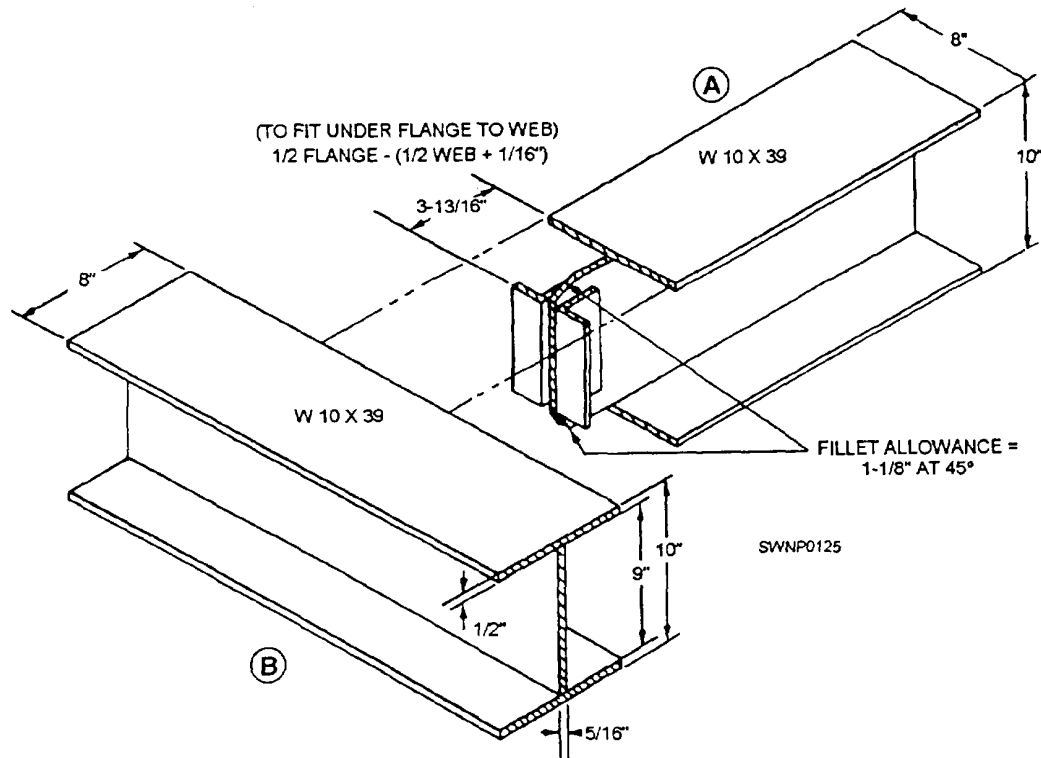

Figure 3-32.—Fabrication and fit-up for joining two beams of the same size.

intersecting beam is smaller; therefore, only one flange is coped to fit the other. The top flanges will be flush. Note that the angles on this connection are to be bolted, rather than welded.

CONNECTION ANGLE LAYOUT

A very common connection with framed construction is the connection angle. The legs of the angles used as connections are specified according to the surface to which they are to be connected. The legs that attach to the intersecting steel to make the connections are termed *web legs*. The legs of the angles that attach to the supporting or intersected steel beam are termed *outstanding legs*. The lines in which holes in the angle legs are placed are termed *gauge lines*. The distances between gauge lines and known edges are termed gauges. An example of a completed connection is shown in figure 3-34. The various terms and the constant dimensions for a standard connection angle are shown in figure 3-35.

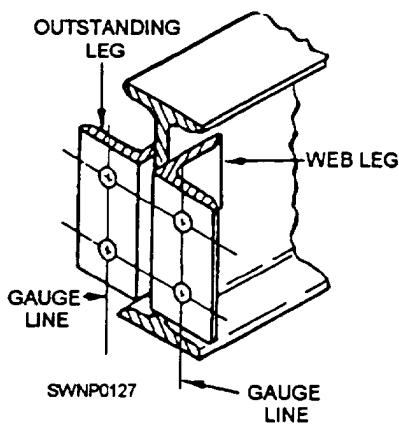

Figure 3-34.—gauge lines.

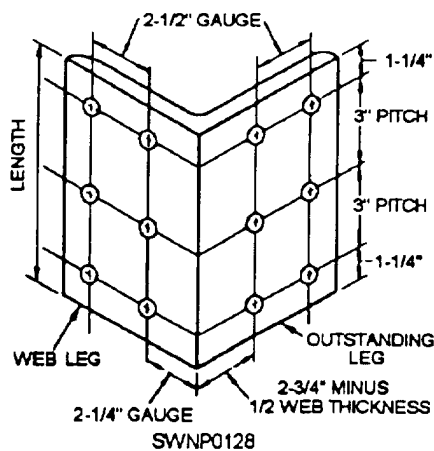

Figure 3-35.—Standard layout for connection angle using 4-inch by 4-inch angle

The distance from the heel of the angle to the first gauge line on the web leg is termed the *web leg gauge*. This dimension has been standardized at 2 1/4 inches (5.6 cm). THIS DIMENSION IS CONSTANT AND DOES NOT VARY.

The distance from the heel of the angle to the first gauge line on the outstanding leg is called the *outstanding leg gauge*. This dimension varies as the thickness of the member, or beam, varies. This variation is necessary to maintain a constant 5 1/2-inch-spread dimension on the angle connection.

The outstanding leg gauge dimension can be determined in either one of the following two ways:

1. Subtract the web thickness from 5 1/2 inches (13.8 cm) and divide by 2.
2. Subtract 1/2 of the web thickness from 2 3/4 inches.

The distance between holes on any gauge line is called *pitch*. This dimension has been standardized at 3 inches (7.5 cm).

The end distance is equal to one half of the remainder left after subtracting the total of all pitch spaces from the length of the angle. By common practice, the angle length that is selected should give a 1 1/4-inch (3-cm) end distance.

All layout and fabrication procedures are not covered in this section. Some examples are shown in figure 3-36. Notice that the layout and fabrication yard has a table designed to allow for layout, cutting, and welding with minimum movement of the structural members. The stock materials are stored like kinds of materials.

The table holds two columns being fabricated out of beams with baseplates and cap plates. Angle clips for seated connections (fig. 3-37) should be installed before erection,

CUTTING AND SPLICING BEAMS

At times, the fabricator will be required to split a beam to make a tee shape from an I shape. This is done by splitting through the web. The release of internal stresses locked up in the beams during the manufacturer's rolling process causes the split parts to bend or warp as the beams are being cut unless the splitting process is carefully controlled.

The recommended procedure for cutting and splitting a beam is first to cut the beam to the desired length and then proceed as follows:

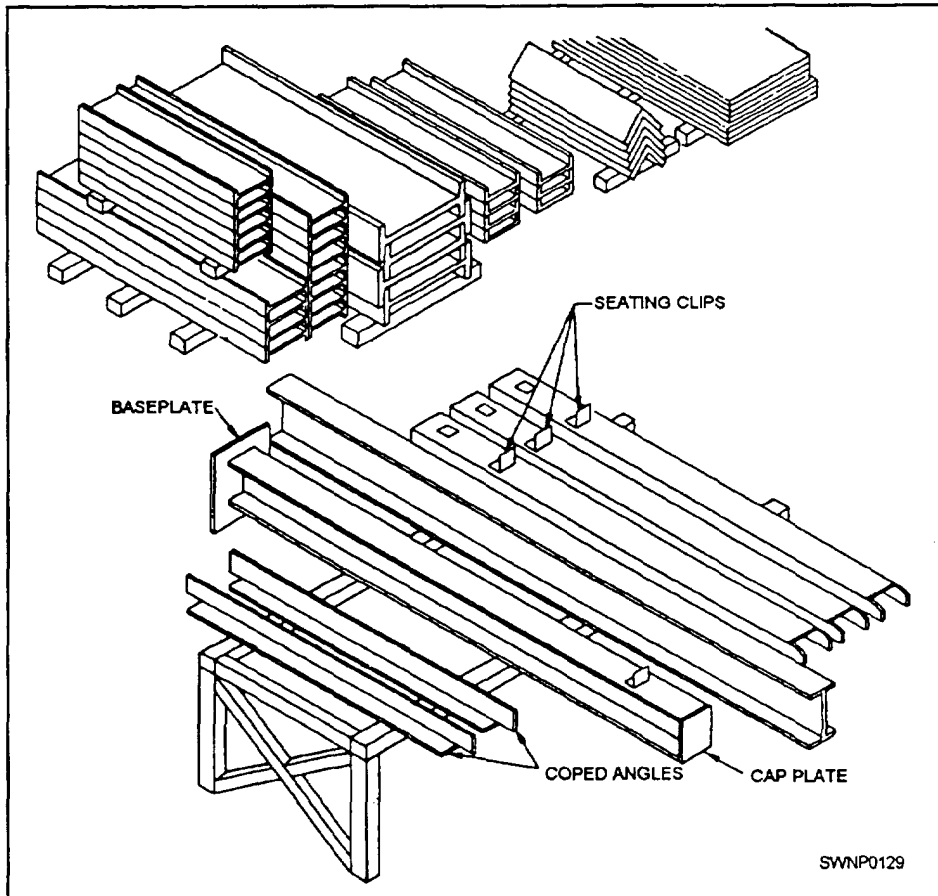

Figure 3-36.—Prefab table and steel storage.

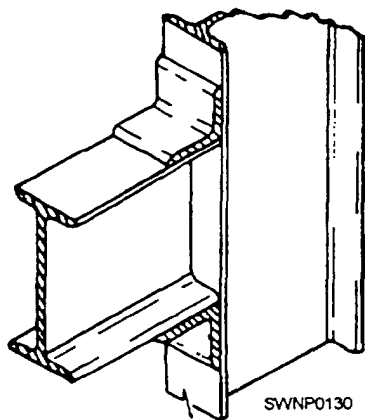

Figure 3-37.—Seated connection.

1. Make splitting cuts about 2 feet (60 cm) long, leaving 2 inches (5 cm) of undisturbed metal between all cuts and at the end of the beam (fig. 3-38). As the cut is made, cool the steel behind the torch with a water spray or wet burlap.

2. After splitting cuts have been made and the beam cooled, cut through the metal between the cuts, starting at the center of the beam and working toward the ends, following the order shown in figure 3-38.

The procedure for splitting a beam also works very well when splitting plate and is recommended when making bars from plate. Multiple cuts from plate can be made by staggering the splitting procedure before cutting the space between slits. If this procedure is used, ensure that the entire plate has cooled so that the bars will not warp or bend.

TEMPLATES

When a part must be produced in quantity, a template is made first and the job laid out from the template. A template is any pattern made from sheet metal, regular template paper, wood, or other suitable material, which is used as a guide for the work to be done. A template can be the exact size and shape of the corresponding piece, as shown in figure 3-39,

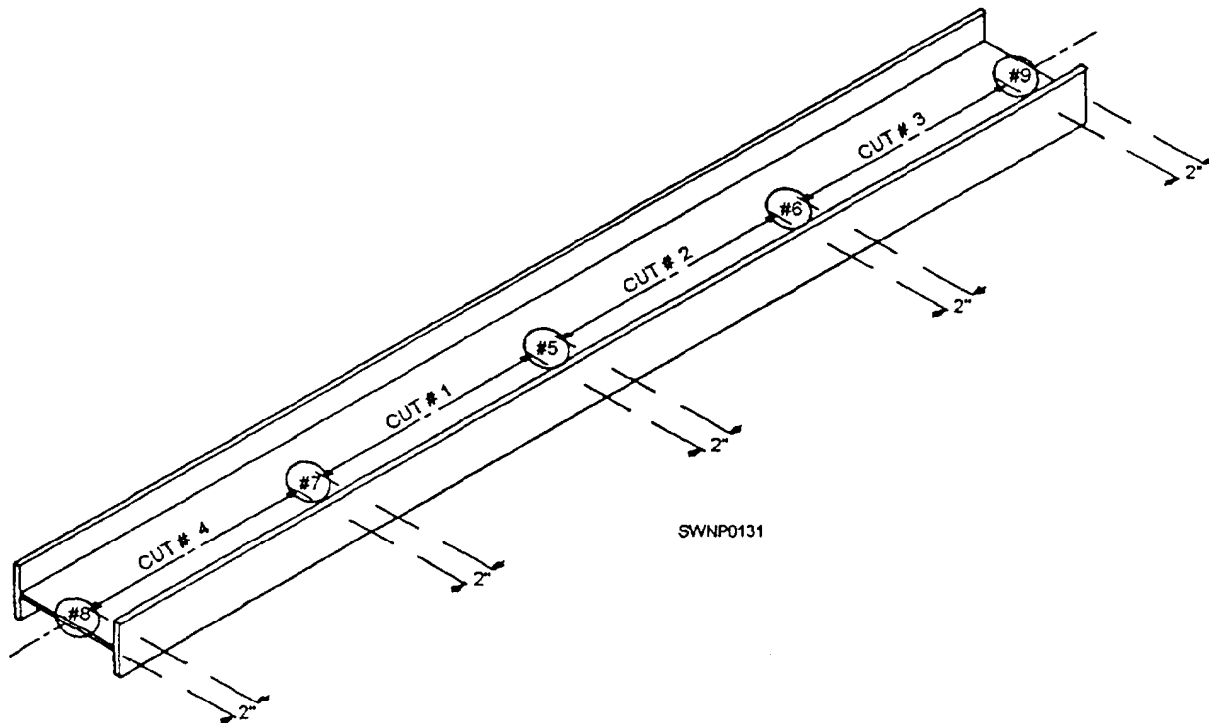

Figure 3-38.—Cutting order for splitting a beam.

views 1 and 2, or it may cover only the portions of the piece that contain holes or cuts, as shown in views 3 and 4. When holes, cuts, and bends are to be made in a finished piece, pilot holes, punch marks, and notches in the template should correspond exactly to the desired location in the finished piece. Templates for short members and plates are made of template paper of the same size as the piece to be fabricated. Templates for angles are folded longitudinal] y, along the line of the heel of the angle (fig. 3-39, view 3).

Accurate measurements in making templates should be given careful attention. Where a number of parts are to be produced from a template, the use of inaccurate measurements in making the template obviously would mean that all parts produced from it will also be wrong.

Template paper is a heavy cardboard material with a waxed surface. It is well adapted to scribe and divider marks. A combination of wood and template paper is sometimes used to make templates. The use of wood or metal is usually the best choice for templates that will be used many times.

For long members, such as beams, columns, and truss members, templates cover only the connections. These templates may be joined by a wooden strip to ensure accurate spacing (fig. 3-39, views 1 and 2).

They may also be handled separately with the template for each connection being clamped to the member after spacing, aligning, and measuring.

In making templates, the same layout tools discussed earlier in this chapter are used. The only exception is that for marking lines, a pencil or Patternmaker's knife is used. When punching holes in a template, keep in mind that the purpose of the holes is to specify location, not size. Therefore, a punch of a single diameter can be used for all holes. Holes and cuts are made prominent by marking with paint.

Each template is marked with the assembly mark of the piece it is to be used with, the description of the material, and the item number of the stock material to be used in making the piece.

In laying out from a template, it is important that the template be clamped to the material in the exact position. Holes are center punched directly through the holes in the template (fig. 3-40), and all cuts are marked. After the template is removed, the marks for cuts are made permanent by rows of renter punch marks.

It is important that each member or individual piece of material be given identifying marks to

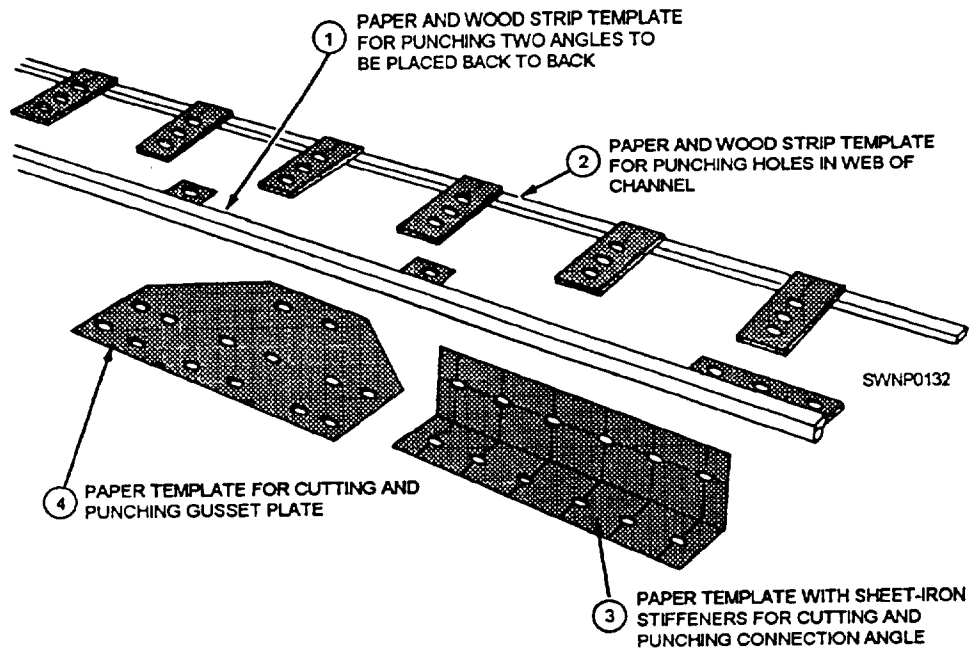

Figure 3-39.—Paper and combination templates.

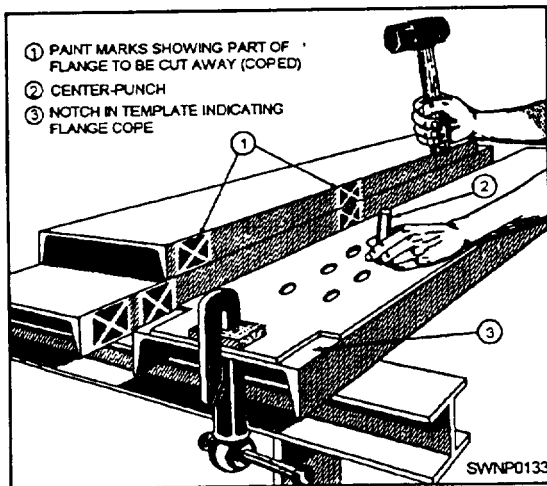

Figure 3-40.—Use of template in laying out a steel channel.

correspond with marks shown on the detail drawing (fig. 3-41).

The ERECTION MARK of a member is used to identify and locate it for erection. It is painted on the completed member at the left end, as shown on the detail drawing, and in a position so that it will be right side up when the member is right side up in the finished structure.

An ASSEMBLY MARK is painted on each piece on completion of its layout so that the piece can be

identified during fabrication and fitting up with other pieces to form a finished member.

PIPE FITTING AND LAYOUT OPERATIONS

Lack of templates, charts, and mathematical formulas need not hinder you in pipe layout. In emergencies, welded pipe of equal diameter can be laid out in the field quickly and easily. By using the methods described here and a few simple tools, you can lay out branches and Y connections as well as turns of any angle, radius, and number of segments. The few simple tools required are both readily available and familiar to the Steelworker through almost daily use. A framing square, a bevel protractor with a 12-inch (20-cm) blade, a spirit level, a spring steel wraparound (or tape), a center punch, a hammer, and a soapstone will meet all needs. (A stiff strip of cardboard or a tin sheet about 3 inches [7.5 cm] wide also makes a good wraparound.) For purposes of our discussion, the long part of the framing square is referred to as the BLADE and the short part as the TONGUE.

LAYOUT OPERATIONS

Two methods of pipe layout are commonly used. They are the one-shot method and the shop method. The ONE-SHOT method is used in the field. With this

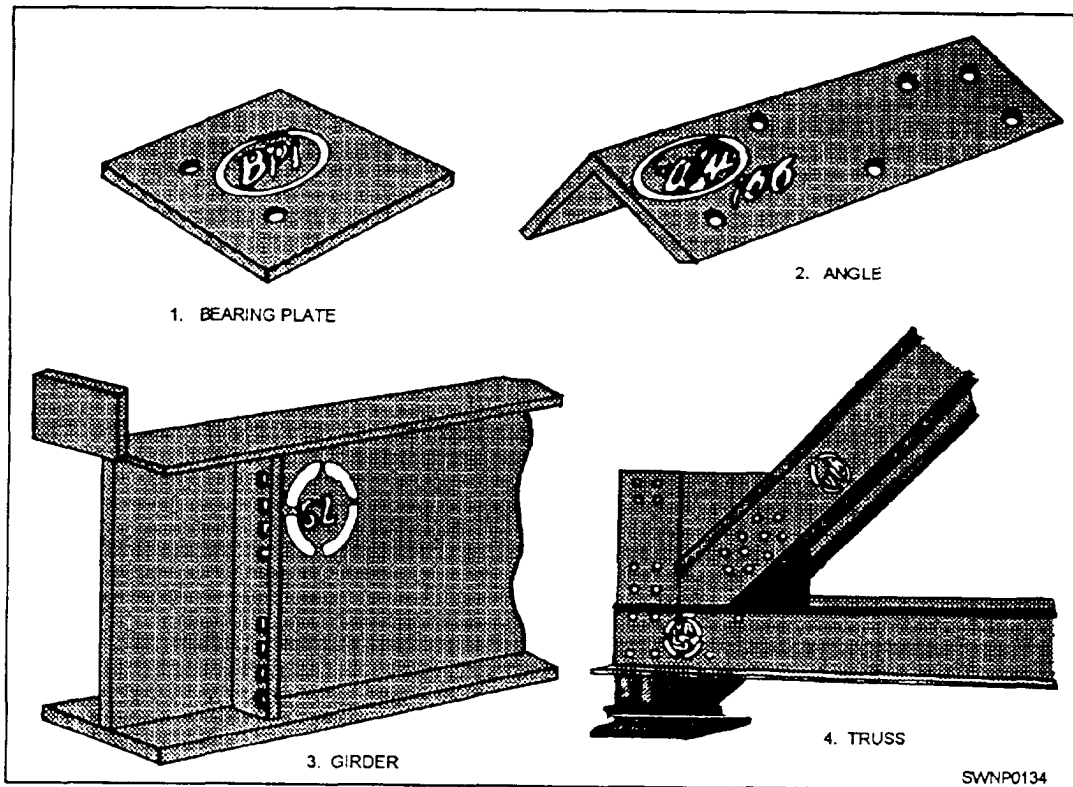

Figure 3-41.—Erection and assembly marks.

method, you use hand tools and make your layout on the pipe to be cut. The one-shot method is so named because you only use it once. In the SHOP METHOD you will make templates for pieces that are going to be duplicated in quantity. As an example, a job order comes into the shop for 25 pieces of 6-inch (15-cm) pipe—all cut at the same angle. Obviously, it would be time consuming to use the one-shot method to produce 25 pieces; hence the shop method is used for laying out. Patterns can be made of template paper or thin-gauge sheet metal. The major advantage of thin-gauge sheet metal templates is when you are finished with them they can be stored for later use.

Keep in mind that all pipe turns are measured by the number of degrees by which they turn from the course set by the adjacent straight section. The angle is measured between the center line of the intersecting sections of pipe. Branch connections are measured in angle of turnaway from the main line. For example, a 60-degree branch is so-called because the angle between the center line of the main pipe and the center line of the branch connection measures 60 degrees. Turns are designated by the number of degrees by which they deviate from a straight line.

QUARTERING THE PIPE

Inlaying out any joint, the first step is to establish reference points or lines from which additional measurements or markings can be made. This is done by locating a center line and dividing the outside circumference of the pipe into 90-degree segments, or quarters. The framing square, the spirit level, and the soapstone are used in these procedures in the following manner: Block the pipe so it cannot move or roll; then place the inside angle of the square against the pipe and level one leg. One point on the centerline is then under the scale at a distance of half the outside diameter of the pipe from the inside angle of the square (fig. 3-42). Repeating at another part of the pipe will

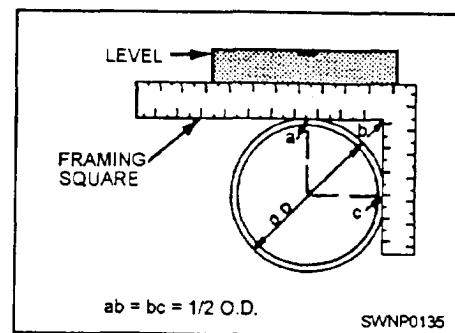

Figure 3-42.—Locating the top and side quarter points.

locate two points and hence the center line. By this same method, the quarter points also may be located. This operation is a must before any layout with the field method.

If you are using a long piece of pipe and are going to cut both ends in addition to the square, you will need a piece of carpenter's chalk line with a plumb bob on each end and two 24- or 36-inch (60- or 90-cm)-flat steel rules (depending on the diameter of the pipe) to locate the top and the bottom center lines. Figure 3-43 shows a plumb bob and rules being used to locate the top and the bottom center lines.

Another one-shot method of quartering pipe is to take a strip of paper and wrap it around the pipe and tear or cut the part that overlaps. The ends should touch. Remove the paper from the pipe and fold it in half, as shown in figure 3-44, view A. Then double the strip once again, as shown in view B. This will divide your strip into four equal parts. Place the strip of paper around the pipe. At the crease marks and where the ends meet, mark the pipe with soapstone and your pipe will be quartered.

TEMPLATE FOR TWO-PIECE TURN

The fact that a length of pipe with square ends can be fabricated by wrapping a rectangular section of plate into a cylindrical form makes available a method (known as parallel forms) of developing pipe surfaces, and hence developing the lines of intersection between

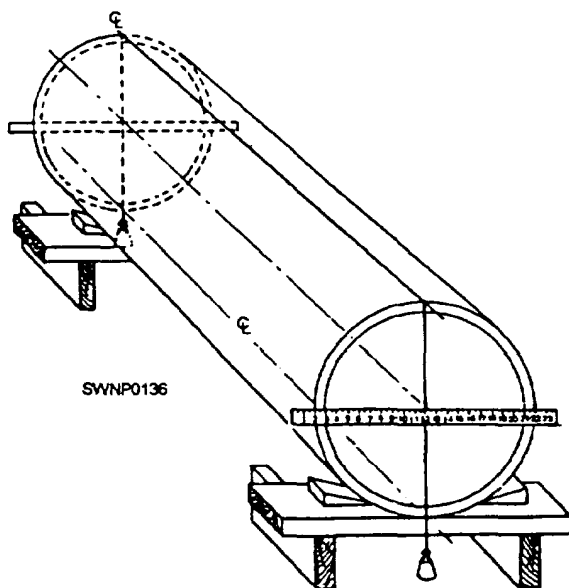

Figure 3-43.—Locating the top and the bottom center lines.

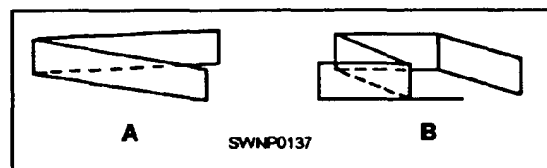

Figure 3-44.—Folding a tip of paper for use in quartering pipe.

pipe walls. Based on this principle, wraparound templates can be made for marking all manner of pipe fittings for cutting preparatory to welding.

The development of a template is done in practice by dividing the circumference (in the end view) of the pipe into a specific number of equal sections. These sections are then projected onto the side view of the desired pipe section. The lengths of the various segments that make up the pipe wall may then be laid out, evenly spaced, on a base line. This line is, in effect, the unwrapped circumference (fig. 3-45). If the template developed in figure 3-45, view C, is wrapped around the pipe with the base line square with the pipe, the curved line, a-b-c-d-e-f-, and so forth, will locate the position for cutting to make a 90-degree, two-piece turn. Draw a circle (fig. 3-45, view A) equal to the outside diameter of the pipe and divide half of it into equal sections. The more sections, the more accurate the final result will be. Perpendicular to the centerline and bisected by it, draw line AI equal to the O.D. (view B). To this line, construct the template angle (TA) equal to one half of the angle of turn, or, in this case, 45 degrees. Draw lines parallel to the centerline from points a, b, c, and so forth, on the circle and mark the points where these lines intersect line a-i with corresponding letters. As an extension of AI but a little distance from it, draw a straight line equal to the pipe circumference or that of the circle in view A. This line (view C) should then be divided into twice as many equal spaces as the semicircle, a-b-c-, and so forth, and lettered as shown. Perpendiculars should then be erected from these points. Their intersections with lines drawn from the points on a-i in view B, parallel to the base line in view C, determine the curve of the template.

SIMPLE MITER TURN

After quartering the pipe, proceed to make a simple miter turn. Locate the center of the cut (fig. 3-46, point c) in the general location where the cut is to be made. Use a wraparound to make line a-b completely around the pipe at right angles to the center

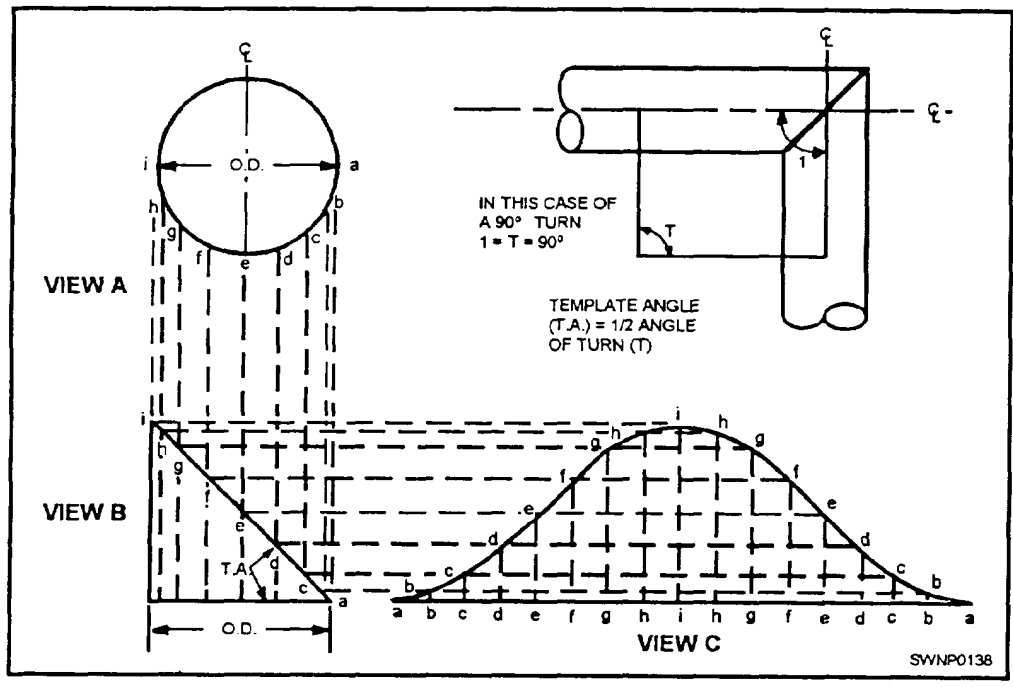

Figure 3-45.—Principles of template layout.

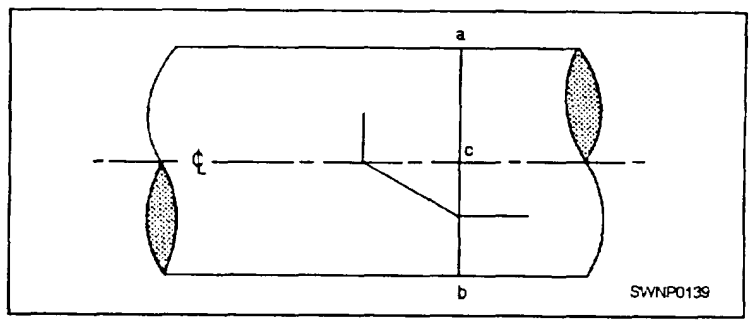

Figure 3-46.—Simple miter turn.

and quarter lines. This establishes a base line for further layout work.

When you are measuring, treat the surface of the pipe as if it were a flat surface. Use a flat-steel rule or tape, which will lie against the surface without kinks, even though it is forced to follow the contour of the pipe. These angles can also be checked for accuracy by sighting with the square.

Use the protractor and square to determine the proper cutback for the desired angle of the miter turn. Start with the protractor scale set at zero so that the flat surface of the protractor and the blade are parallel. You can now set the protractor for the number of

degrees desired. After you have the correct setting, lock the blade. Place the protractor on the square with the bottom blade on the outside diameter of the pipe. Now read up to the cutback on the vertical blade of the square. You must be sure that the flat surface of the protractor is flush against the blade of the square (fig. 3-47). The outside radius of the pipe should have been determined during the quartering operation.

After you have obtained the cutback measurement, mark one half of this measurement off along the center line on top of the pipe. From the opposite side of the base line, measure off the same

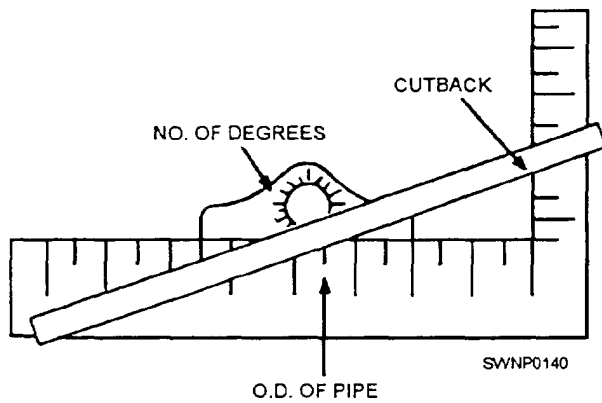

Figure 3-47.—Finding the cutback.

distance along the bottom quarter line. Make punch marks with the center punch on each side of the line, along the side quarter lines. These marks will make it easy to align the pipe for welding after the joint is cut. Use the spring steel wraparound and pull the loop to the cutback point. Next, draw a chalk line over the top half of the pipe through the first cutback point. **(NOTE:** Do not allow the wraparound to twist or kink, and hold the chalk at a right angle to the wraparound while marking the pipe.) Now roll the pipe one-half turn and mark a chalk line in the same way around the bottom half of the pipe.

TWO-PIECE TURN

If a template is not available, you may determine the dimensions and markings for the cut necessary for a two-piece welded turn of any angle between 1 degree and 90 degrees by making a full-sized drawing, as shown in figure 3-48.

Draw the center lines intersecting at *b* by using the angle of turn *T* and then draw the outlines of the pipes by using the center lines and the diameter *D*. These will intersect at *a* and *c*. By laying the pipe over the drawing so that point *b* will coincide with that determined by construction details, you can draw the lines *a-b* and *c-b* in preparation for miter cutting and beveling.

After being prepared for welding, one section of pipe should be rotated through 180 degrees to form the desired angle, and then it should be tack-welded.

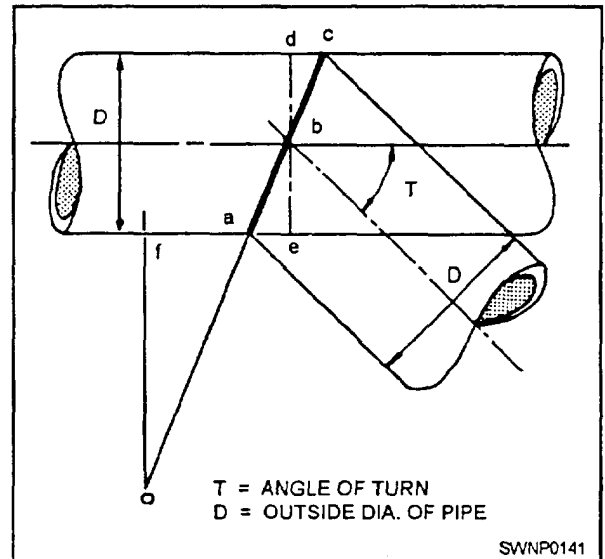

Figure 3-48.—To locate cut on a pipe for any angle two-piece turn.

Spacing should be slightly greater at the inside of the turn.

WELDED TEE

To lay out the template for cutting the branch and header for a 90-degree tee with header and branch of equal diameter, draw the side and end view, as shown in figure 3-49, views A and B.

In making the template for the branch in figure 3-49, view A, draw lines 1-5 at 45 degrees to the center line. Lay off distance 1-P equal to twice the thickness of the pipe wall and draw the smooth curve s-P-s. Now, project point P from view A to view B and draw the lines P-t radially. At a distance above point t equal to the thickness of the header wall, draw a-t horizontally, and vertical lines a-a and t-t. With lower points a as center, swing arcs r-s. Using the intersections of these arcs as centers and with the same radius, draw the curved lines a-be-d-e and e d-c-b-a.

Divide the outside circumference of the branch top into equal parts and draw the vertical lines b-b, c-c, and so forth. Also, draw the horizontal base line a-a.

Lay off the unwrapped circumference (fig. 3-49, view D), and divide each half of it into the same number of equal parts as the branch semicircumference. In view D, you should plot the distances a-a, b-b, and so forth, from view B. This gives the distances from the base line to the branch curve of the intersection and determines the location of the branch template.

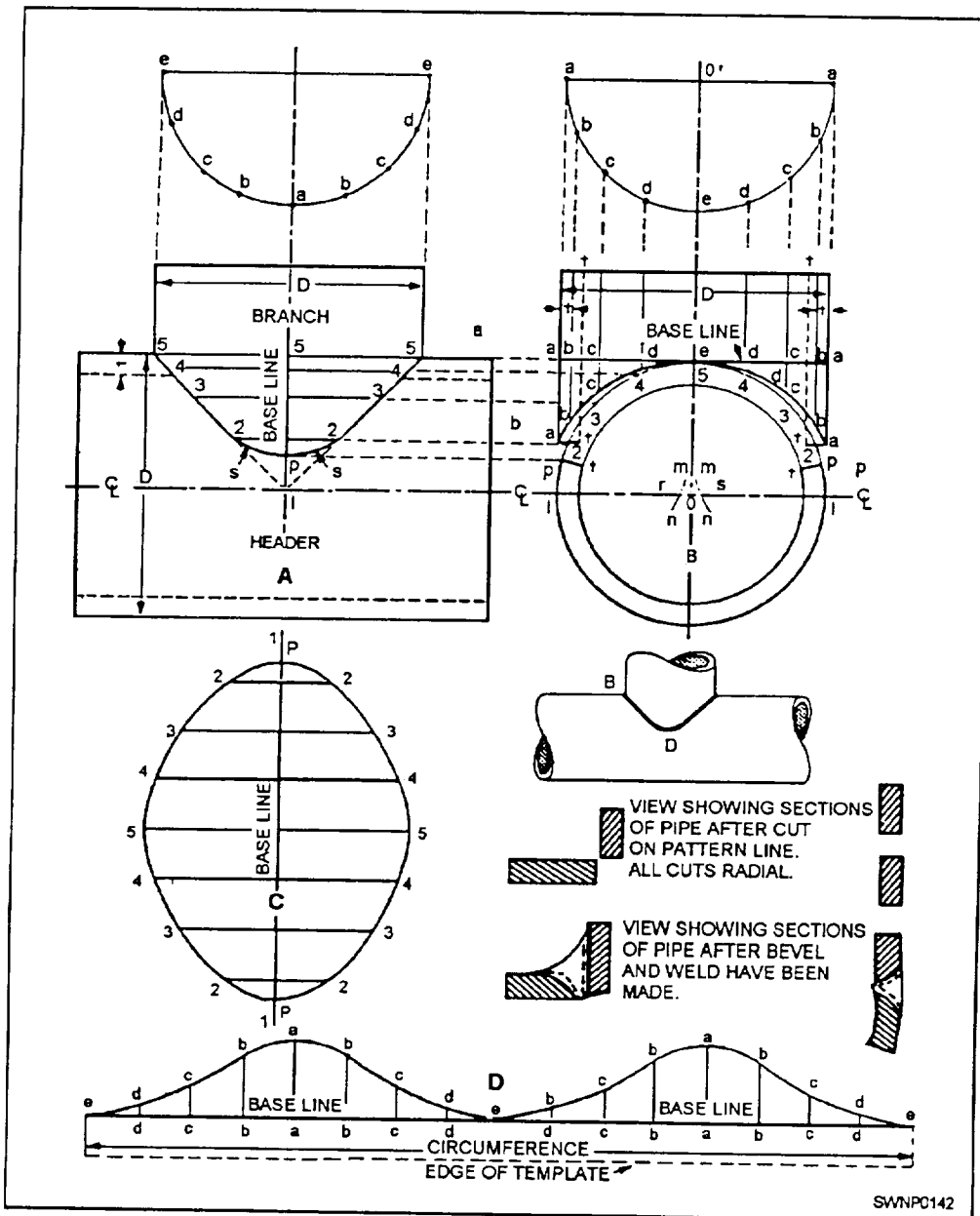

Figure 3-49.—90-degree tee.

To make the template for the hole in the header, divide the circumference of the header into equal parts, as at points 1, 2, 3, and so forth. Next, project these points across to view A (fig. 3-49), as shown. As in view C, lay off the line 1-5-1 equal to one half of the circumference of the header, and divide it into the same number of equal parts as was done on the header. Locate point P, a distance from 1 in view C equal to 1-P in view B. With this point P and the distances 5-5, 4-4, and so forth, in view A, plotted as shown in view C, the curve of the template is located.

BRANCH CONNECTIONS

Branch to header connections (fig. 3-50) at any angle of 45 degrees to 90 degrees can be fabricated in equal diameter pipe by the following procedures. (Note that angles less than 45 degrees can be made, but a practical limitation is imposed by the difficulty of welding the crotch section.)

First, quarter both sections of pipe as before. Then locate the center line of the intersection (point B) on the header and draw line GF around the pipe at this

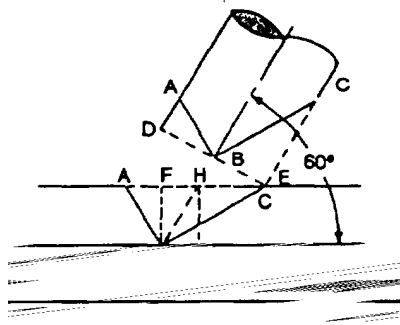

Figure 3-50.—Branch connections

point. Set the diameter FG on the blade of the square. Set and lock the protractor at one fourth of the number of degrees of turnaway from the header (in the example, $1/4$ of $60^\circ = 15^\circ$). With the blade along FG, the first cutback measurement, FA, will be indicated on the tongue of the square. Measure off this distance along the center line of the header from line FG and mark point A. As described before, join point A with the points of intersection of line FG and the two side quarter lines to outline the first cut.

With the same protractor setting, flip the square and mark point H. Distance FH is equal to FA. FH is the first portion of the second cutback measurement. With the same settings and with the square upside down (as compared to before), locate point I the same way you located point H.

Now, set the protractor to one half of the number of degrees of turnaway from the header (in the example, $1/2$ of $60^\circ = 30^\circ$). With the blade set to the diameter, the second portion, HD, of the second cutback measurement will be indicated on the tongue. The second cutback measurement is the total distance FC. Connect points C and B and connect C with the point, which corresponds to B, on the quarter line on the opposite side of the header. This outlines the second cut and completes the marking of the header.

Use the same two cutback measurements to lay out the end of the branch. Branch cutback distance DA is equal to header cutback distance FA. Branch cutback distance EC is equal to header cutback distance FC. If the branch end is square, make cutback measurements from the end, rather than marking in a circumferential line. Make all cuts as before, and level and join the branch and header by welding.

WELDED TEE (BRANCH SMALLER THAN THE HEADER)

One of the best types of joint for a 90-degree branch connection where the branch is smaller than the header is obtained by inserting the smaller branch pipe through the wall down to the inner surface of the header. The outside surface of the branch intersects the inside surface of the header at all points. When the header is properly beveled this type of intersection presents a very desirable vee for welding. In ease templates or template dimensions are not available, the line of cut on both header and branch can be located by other methods, but the use of templates is recommended.

In the first method, the square end of the branch should be placed in the correct position against the header and the line of intersection marked with a flat soapstone pencil (fig. 3-51). Since radial cutting is used in this case and since the outer branch wall should intersect the inner header wall, point B should be located on both sides of the branch a distance from A equal to slightly more than the header wall thickness. A new line of cut is then marked as a smooth curve through the points, tapering to the first line at the top of the header. Following radial cutting, the joint should then be beveled.

The branch should be slipped into the hole until even with point B to locate the line of cut on the branch. A soapstone pencil may then be used to mark the line for radial cutting. No beveling is necessary.

A second method for larger diameter pipe is shown in figure 3-52. After the centerlines have been drawn, the branch should be placed against the header, as shown. By means of a straightedge, the distance between A and the header wall is determined, and this measurement above the header is transferred to the branch wall, as represented by the curved line a-b-c.

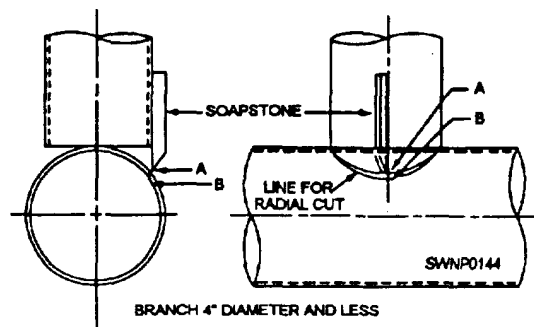

Figure 3-51.—Method where the line of cut is first marked on main.

After this line is radially cut, the branch may be used to locate the line of cut on the header, allowing for the intersection of the outer branch wall and inner header wall as before. This line should be radially cut, followed by beveling.

In making an eccentric branch connection the extreme case being where the side of the branch is even with the side of the header, a similar procedure is followed, as shown in figure 3-53.

THREE-PIECE Y CONNECTION

The entire procedure for fabrication of an equal diameter, three-piece Y connection is based on individual operations already described. As the first step, quarter the end of the three pieces of pipe and apply circumferential lines. When the three pieces are welded together to form the Y, there will be three center lines radiating from a common point.

The open angle between each pair of adjacent center lines must be decided, for each of these angles will be the angle of one of the branches of the Y. As shown in figure 3-54, these open angles determine the angle of adjoining sides of adjacent branches. Thus half of the number of degrees between center lines A and B are included in each of the adjoining cutbacks between these two branches. The same is true with respect to the other angles and cutbacks between

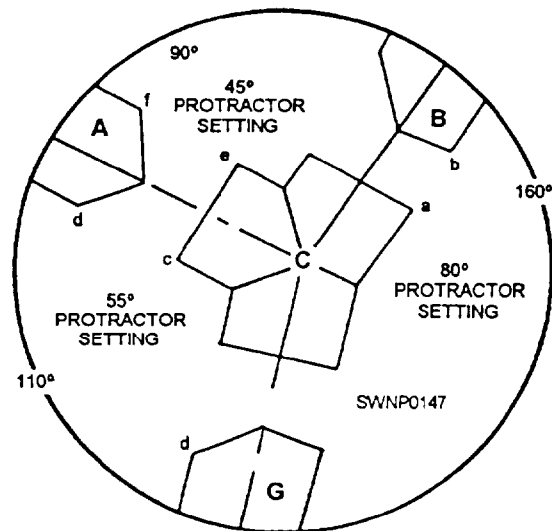

Figure 3-54.—Three-piece Y connection.

center lines. Moreover, each piece of pipe must have a combination of two angles cut on the end.

To determine the amount of cutback to form an angle of the Y, set the protractor at one half of the open angle between adjacent branch center lines. Place the protractor on the square, crossing the outside radius measurement of the pipe on the tongue of the square, and read the cutback distance off the blade of the square. Mark off this distance on one side quarter line on each of the two pieces that are to be joined. Then mark the cutback lines. Repeat this procedure for the other two angles of the Y, taking care to combine the cutbacks on each pipe end. Three settings of the protractor determine all cutbacks.

An alternate method for determining each cutback is to treat two adjacent branches as a simple miter turn. Subtract the number of degrees of open angle between center lines from 180 degrees and set the protractor at one half of the remaining degrees. Cross the outside radius measurement on the tongue. Mark one side of each adjoining pipe section. Repeat for the other two branches. Take care to combine the proper cutbacks on each pipe end. Set the protractor for each open angle of the Y connection.

The computations and measurements for the layout (fig. 3-54) are shown in table 3-1. The pipe is 12 inches in diameter and has a radius of 6 inches (15 cm)

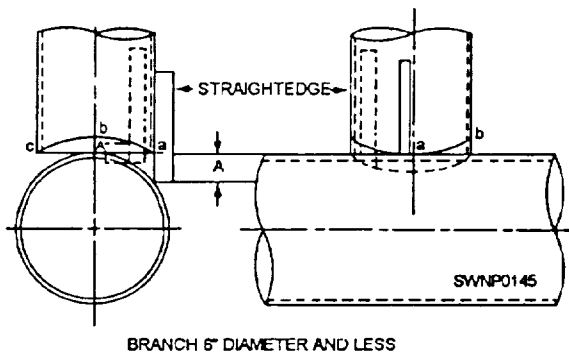

Figure 3-52.—Line of cut is first marked on branch with this method.

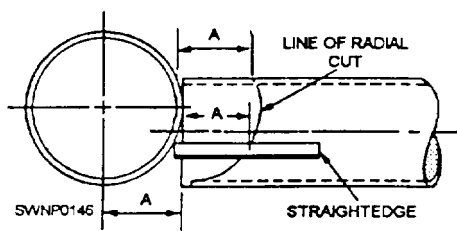

Figure 3-53.—Marking cut on branch for eccentric branch connection.

Table 3-2.—Computations and Measurement for a Y Connection.

	ACB	ACG	BCG
Open angle between center lines	90 deg.	110 deg.	160 deg.
Protractor setting (half of each angle)	45 deg.	55 deg.	80 deg.
Cutbacks	6"	4 1/8"	1 1/16"
Center lines	A	B	G
Paired cutback measurements (inches)	fe = 6" cd = 4 1/8"	ab = 1 1/16" fe = 6"	ab = 1 1/16" cd = 4 1/8"

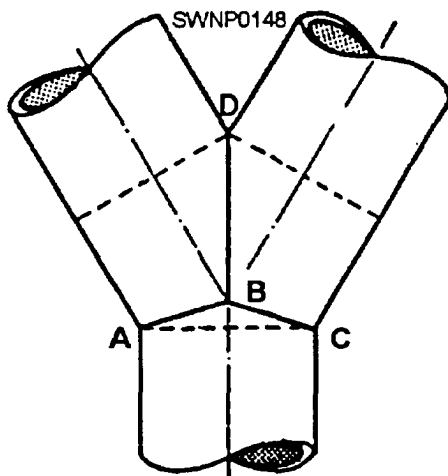

Figure 3-55.—True Y.

LAYOUT OF A TRUE Y

In laying out pipe for the fabrication of a true Y without the use of templates or tables, a full-sized drawing of the intersection (fig. 3-55) should be made. The intersection of the center lines of the three pipes will locate point B, and lines from B to the intersections of the pipe walls will locate points A, C, and D. From these points the pipe may be marked for cutting. Miter cutting, followed by suitable beveling, is necessary in preparing the pipe for welding.

TEMPLATE LAYOUT FOR TRUE Y BRANCHES AND MAIN LINES

In laying out a template for a true Y, a drawing of the intersection should be made, as shown in figure 3-56, view A. After drawing the lines of intersection,

the same essential methods as for other templates are followed. Note that here it is suggested the equally divided semicircumferences are more conveniently placed directly on the base line. The distances from the base line to the line of intersection plotted on the unwrapped base line determine the template.

ORANGE PEEL HEAD

A number of different types of heads are used in welded pipe construction. Here, we are interested in one general type, the ORANGE PEEL, since it will often concern you in your work. A main advantage of the orange peel is that it has high strength in resisting internal pressure.

If templates or tables are not available for making an orange peel head, a reasonably accurate marking can be secured by the following procedure for laying out a template.

The number of arms to make an orange peel head should be the minimum number which can be easily bent over to form the head. Five arms and welds are the recommended minimum for any pipe; this number should be increased for larger sizes of pipe. Dividing the circumference by 5 is a good method for deciding the number of arms, provided, there are at least 5.

To lay out the template, draw the side and end views (fig. 3-57). Divide the pipe circumference in view B into the same number of equal parts as it is planned to have welds, and draw the radial lines o-a, o-b, and so on. Project the points a, b, and so on, in this view.

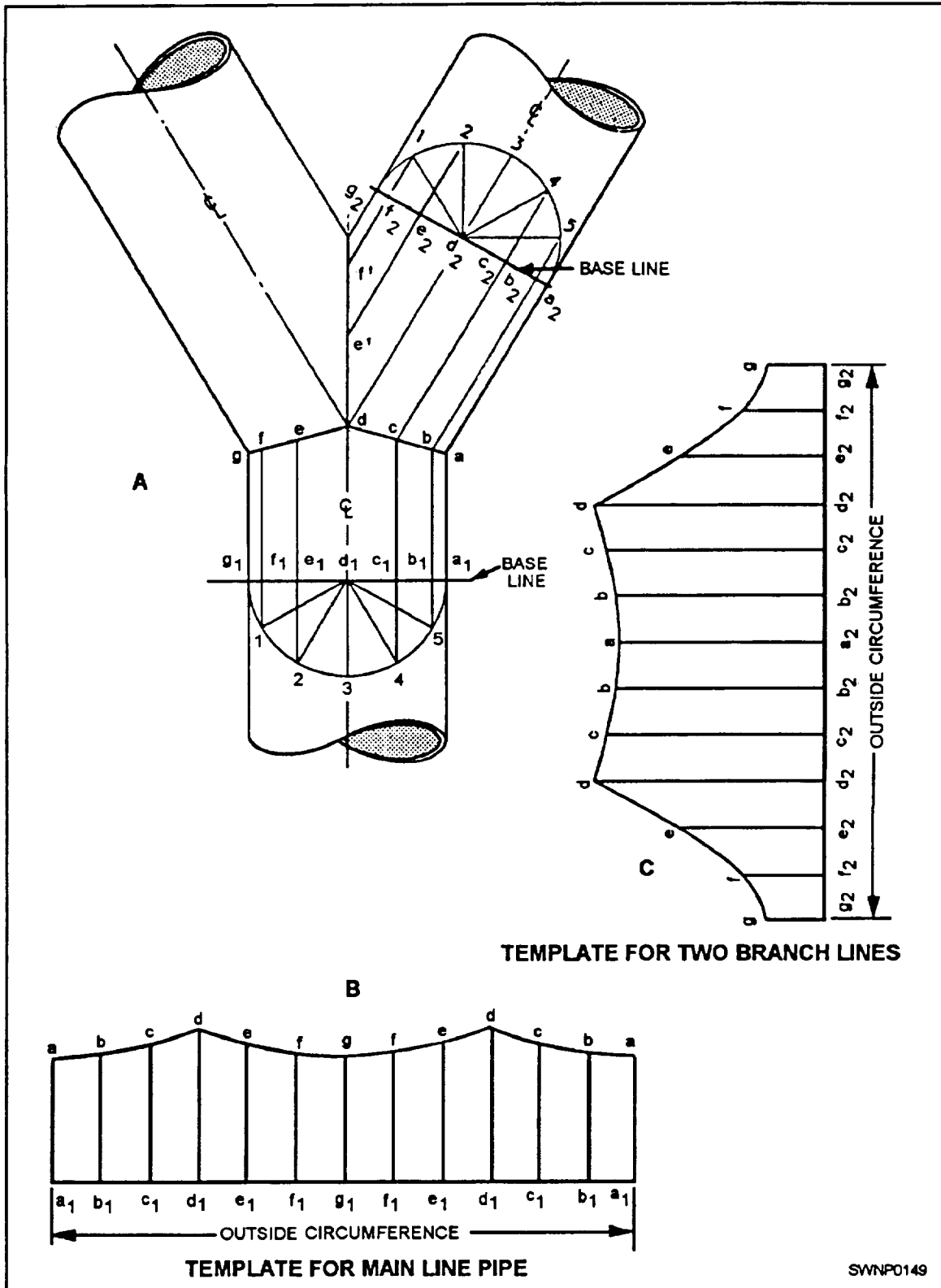

Figure 3-56.—Template for true Y branches and main of equal diameter.

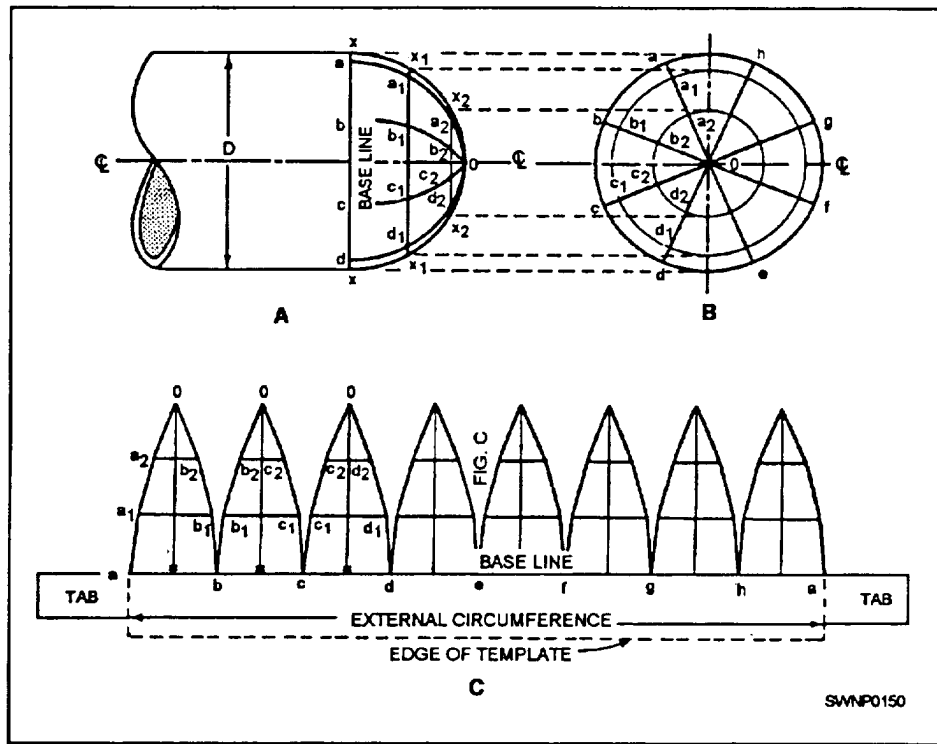

Figure 3-57.—Orange peel head.

Now, divide x-o-x into equal parts—in this case, 6. Then draw the lines x1-x1 and x2-x2. These represent the concentric circles in view B. In laying out the template, the distances a-b, b-c, a1-b1, a2-b2, and so on, are taken from view B. The distances x+, x-x1, x-x2, b-b1, and so on, are taken from view A. It is not actually necessary to draw views A and B since all the

values can be determined by a simple computation. All cutting should be radial followed by a beveling cut.

A one-shot field method of making an orange peel is shown in figure 3-58. This method can be used when you are going to make only one orange peel. Incidentally, the tables shown in figure 3-58 will help to lineup your template better.

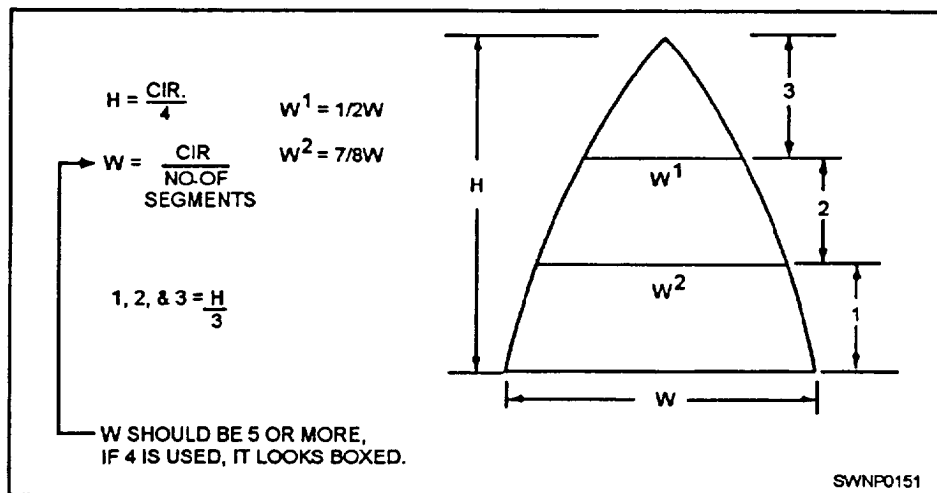

Figure 3-58.—A field method of making an orange peel.

PIPE CUTTING

Cutting pipe is not much different than cutting structural shapes, except that you must always keep in mind that the cut will either be radial or miter. The gas cutting torch is used to cut pipe fittings for welding. Procedures relating to the use of the cutting torch are given in volume 1, chapter 4. The torch maybe hand operated, or it maybe mounted on a mechanical device for more accurate control.

Cutting machines may be used to prepare many fittings without the use of templates. These machines cut and bevel the pipe in one operation-the bevel extending for the full pipe wall thickness. When the pipe is cut by hand, beveling is done as a second operation.

For many types of welded fittings, a RADIAL cut is required before beveling. Radial cutting simply means that the cutting torch is held so it is perpendicular to the interior center line at all times. In other words, the cutting orifice always forms a continuation of a radius of the pipe, making the cut edge square with the pipe wall at every point. Figure 3-59 shows radial cutting. Except in the case of the blunt bull plug, for which the radial cut provides the proper vee, the radial cut should be followed by a beveling cut for pipe with 3/16 inch (4.8 mm) or more wall thickness.

In MITER cutting the torch tip is held so that the entire cut surface is in the same plane. The miter cut is followed by a beveling cut, leaving a 1/32- to 1/16-inch (.8 to 1.6-mm) nose at the inner wall. Figure 3-60 shows miter cutting.

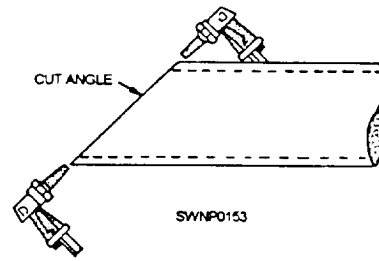

Figure 3-60.—Miter cutting.

PIPE BENDING

Any piping system of consequence will have bends in it. When fabricating pipe for such a system, you can make bends by a variety of methods, either hot or cold, and either manually or on a power-bending machine. Cold bends in pipe are usually made on a bending machine. Various types of equipment are available, ranging from portable handsets to large hydraulically driven machines that can cold bend pipe up to 16 inches (40.64 cm) in diameter. You will be concerned primarily with hot bending techniques, using a bending slab or using a method known as wrinkle bending.

TEMPLATES

Whatever method you use to bend pipe, you should normally have some pattern that represents the desired shape of the bend. Templates made from wire or small, flexible tubing can be invaluable in preparing new installations as well as in repair work. When properly made, they will provide an exact guide to the bend desired.

One of the simple types of bend template is the center line template. A centerline template is made to

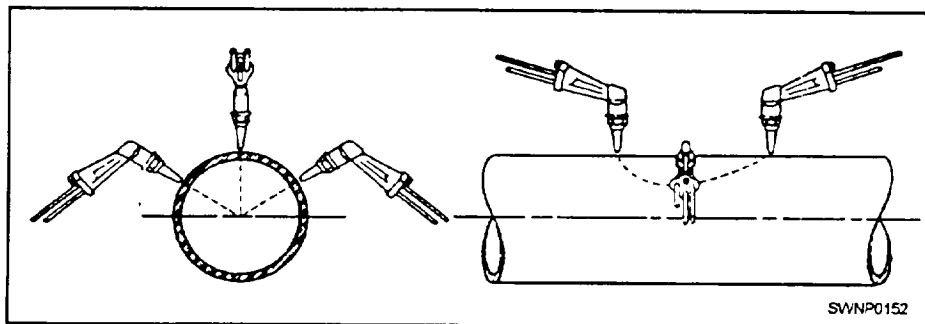

Figure 3-59.—Radial cutting.

conform to the bend or bends of the pipe to be made. It is used to lay off the bend area on the pipe and as a guide during the pipe or tube bending operation. Figure 3-61 shows the use of a center line template. These templates are made of wire, or rod, and are shaped to establish the center line of the pipe to be installed. The ends of the wire are secured to special clamps, called flange spiders. A clearance disc, which must be the same diameter as the pipe, is used if there is any doubt about the clearance around the pipe.

HOT BENDS

Hot bends are accomplished on a bending slab (fig. 3-62). This slab requires little maintenance beyond a light coating of machine oil to keep rust in check.

As a preliminary step in hot bending, pack the pipe with dry sand to prevent the heel or outside of the bend from flattening. If flattening occurs, it will reduce the

cross-sectional area of the pipe and restrict the flow of fluid through the system.

Drive a tapered, wooden plug into one end of the pipe. Place the pipe in a vertical position with the plugged end down, and fill it with dry sand. Leave just enough space at the upper end to take a second plug. To ensure that the sand is tightly packed, tap the pipe continually with a wooden or rawhide mallet during the filling operation. The second plug is identical with the first, except that a small vent hole is drilled through its length; this vent permits the escape of any gases (mostly steam) that may form in the packed pipe when heat is applied. No matter how dry the sand may appear, there is always a possibility that some moisture is present. This moisture will form steam that will expand and build up pressure in the heated pipe unless some means of escape is provided. If you do not provide a vent, you will almost certainly blow out one of the plugs before you get the pipe bent.

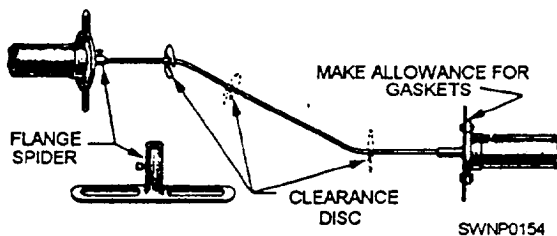

Figure 3-61.—Center line template.

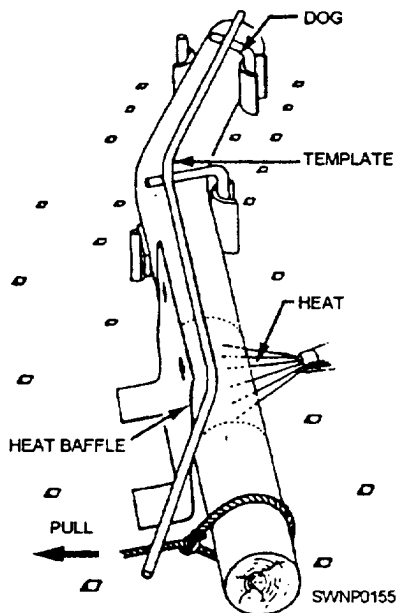

Figure 3-62.—Bending on a slab.

When you have packed the pipe with sand, the next step is to heat the pipe and make the bend. Mark the bend area of the pipe with chalk or soapstone, and heat it to an even red heat along the distance indicated from A to B in figure 3-63. Apply heat to the bend area first on the outside of the bend and then on the inside. When an even heat has been obtained, bend the pipe to conform to the wire template. The template is also used to mark the bend area on the pipe.

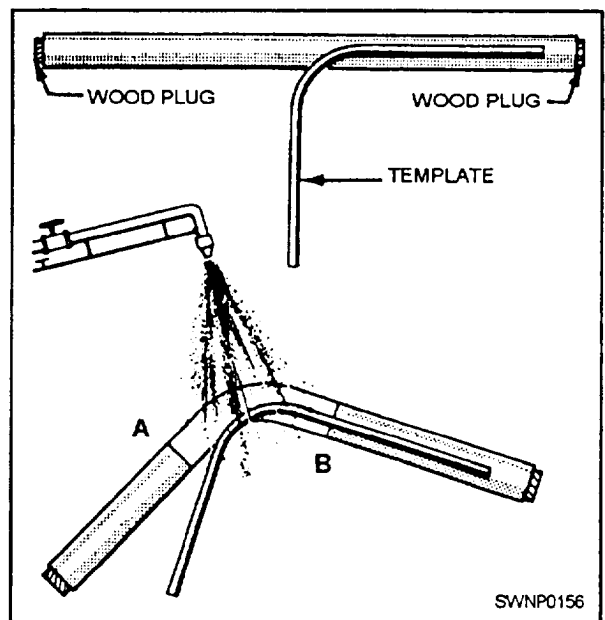

Figure 3-63.—Heating and bending pipe to conform to wire template.

The main problem you will have in bending copper tubing and pipe is preventing wrinkles and flat spots. Wrinkles are caused by compression of the pipe wall at the throat (inside) of the bend. Flat spots are caused by lack of support for the pipe wall, by stretch in the heel (outside) of the bend, or by improper heating.

If the pipe is properly packed and properly heated, wrinkles and flat spots can be prevented by bending the pipe in segments so that the stretch is spread evenly over the whole bend area. When a pipe is bent, the stretch tends to occur at the middle of the bend. If the bend area is divided into a number of segments and then bent in segments, the stretch will occur at the center of each segment and thus be spread more evenly over the bend area. Another advantage of bending in segments is that this is almost the only way you can follow a wire template accurately.

When bending steel and some other piping materials, you can control wrinkles and flat spots by first overbending, the pipe slightly and then pulling the end back (fig. 3-64).

Hot bends are made on a bending slab (fig. 3-64). The pull to make the bend is exerted in a direction parallel to the surface of, the bending slab. The necessary leverage for forming the bend is obtained by using chain falls, by using block and tackle, or by using a length of pipe that has a large enough diameter to slip over the end of the packed pipe. Bending pins and hold-down clamps (dogs) are used to position the bend at the desired location.

Be sure to wear asbestos gloves when working on hot bending jobs. Pins, clamps, and baffles often have to be moved during the bending operation. These items absorb heat radiated from the pipe as well as from the torch flame. You cannot safely handle these bending accessories without proper gloves.

Each material has its peculiar traits, and you will need to know about these traits to get satisfactory

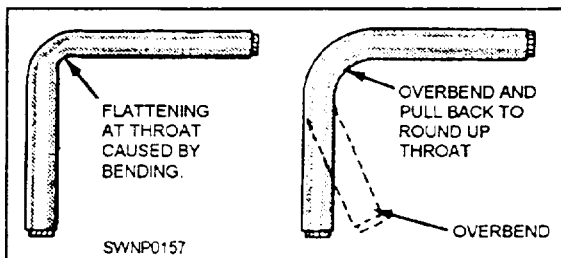

Figure 3-64.—Overbending to correct flattening of pipe.

results. The following hints for bending different materials should prove helpful:

WROUGHT IRON—Wrought iron becomes brittle when hot, so always use a large bend radius. Apply the torch to the throat of the bend instead of to the heel.

BRASS—Do not overbend, as brass is likely to break when the bend direction is reversed.

COPPER—Hot bends may be made in copper, although the copper alloys are more adaptable to cold bending. This material is one that is not likely to give any trouble.

ALUMINUM—Overbending and reverse bending do not harm aluminum, but because there is only a small range between the bending and melting temperature, you will have to work with care. Keep the heat in the throat at all times. You will not be able to see any heat color, so you must depend on “feel” to tell you when the heat is right for bending. You can do this by keeping a strain on the pipe while the bend area is being heated. As soon as the bend starts, flick the flame away from the area. Play it back and forth to maintain the bending temperature and to avoid overheating.

CARBON-MOLYBDENUM and CHROMIUM-MOLYBDENUM—These may be heated for bending, if necessary, but caution must be exercised so as not to overheat the bend area. These types of metal are easily crystallized when extreme heat is applied. Pipes made from these materials should be bent cold in manual or power-bending machines.

WRINKLE BENDS

It may seem odd that after describing precautions necessary to keep a bend free of wrinkles, we next describe a method which deliberately produces wrinkles as a means of bending the pipe. Nevertheless, you will find the wrinkle-bending technique a simple and direct method of bending pipe, and perhaps in many pipe-bending situations, the only convenient method. This would particularly be the case if no bending slab were available or if time considerations did not permit the rather lengthy sand-packing process.

Basically, wrinkle bending consists of a simple heating operation in which a section of the pipe is heated by a gas welding torch. When the metal becomes plastic (bright red color), the pipe is bent SLIGHTLY, either by hand or by means of tackle

rigged for that purpose. The unheated portion forms the heel (outside) of the bend, while the wrinkle is formed at the throat (inside) of the bend due to compression.

It should be understood that the pipe should not be bent through very large angles (12 degrees being considered the maximum for one wrinkle) to avoid the danger of the pipe buckling. The procedure in making a large bend is to make several wrinkles, one at a time. If, for example, you want to produce a bend of 90 degrees, a minimum of eight separate wrinkles could be made. Figure 3-65 shows a 90-degree bend made with ten separate wrinkles. The formula to determine the number of wrinkles is to divide the degrees per wrinkle required into the degrees of the bend required.

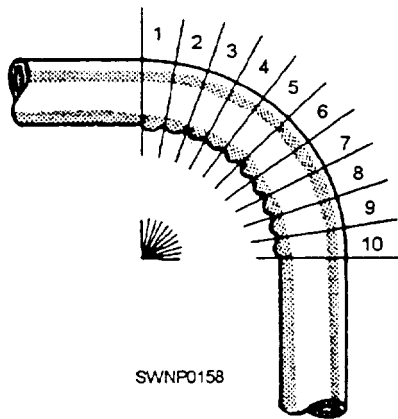

Figure 3-65.—90-degree bend made with ten separate wrinkles.

Wrinkle bending has been successful on pipe of more than 20 inches in diameter. Experience has shown that, for 7-inch-diameter pipe and over, more complete and even heating is accomplished using two welding torches, rather than one. In any event, the heating procedure is the same—the torch or torches being used to heat a strip approximately two thirds of the circumference of the pipe (fig. 3-66). The heated strip need not be very wide (2 to 3 inches, or 5.08 to 7.62 cm, is usually sufficient) since the bend will only be through 12 degrees at most. The heated portion, as we have noted, is the part which will compress to become the inside of the bend. The portion which is not heated directly will form the outside of the bend.

The technique most often used to bend the pipe, once it has been heated, is simple and straightforward. The pipe is merely lifted up by hand (or by tackle), while the other end is held firmly in position.

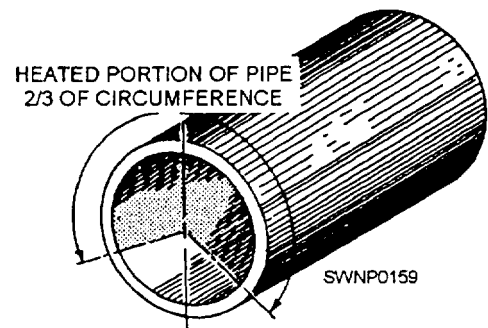

Figure 3-66.—Part of pipe heated before wrinkle bending.

